



HEARTH PRODUCTS

P/N 506023-10 Rev. B 05/2011

This manual is one of a set of two supporting this product. Refer to P/N 506025-05 for Care and Operation Instructions.

Ce manuel est disponible en français, simplement en faire la demande. Numéro de la pièce 506223-13.

INSTALLATION INSTRUCTIONS

Montebello See-Through
Power Vent DV Gas Fireplaces



MODELS

LSM40ST-N-PV



Intertek

Intertek Report No.
100326550PRT-001

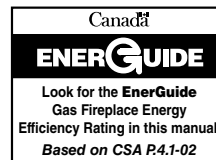

Look for the EnerGuide
Gas Fireplace Energy
Efficiency Rating in this manual.
Based on CSA P.4.1-02



INSTALLER: Leave this manual with the appliance.
CONSUMER: Retain this manual for future reference.
INSTALLATEUR : Laissez cette notice avec l'appareil.
CONSOMMATEUR : Conservez cette notice pour consultation ultérieure.

This appliance may be installed in an aftermarket permanently located, manufactured home (USA only) or mobile home, where not prohibited by local codes. This appliance is only for use with the type of gas indicated on the rating plate. This appliance is not convertible for use with other gases unless a certified kit is used.

! WARNING / AVERTISSEMENT / AVISO

- HOT GLASS WILL CAUSE BURNS.
- DO NOT TOUCH GLASS UNTIL COOLED.
- NEVER ALLOW CHILDREN TO TOUCH GLASS.



- UNE SURFACE VITRÉE CHAUDE PEUT CAUSER DES BRÛLURES.
- LAISSER REFROIDIR LA SURFACE VITRÉE AVANT D'Y TOUCHER.
- NE PERMETTEZ JAMAIS À UN ENFANT DE TOUCHER LA SURFACE VITRÉE.

- EL VIDRIO CALIENTE CAUSARÁ QUEMADURAS.
- USTED DEBE NUNCA TOCAR EL VIDRIO CALIENTE.
- LOS NIÑOS DEBEN NUNCA TOCAR EL VIDRIO.

WARNING: If the information in these instructions is not followed exactly, a fire or explosion may result, causing property damage, personal injury, or death.

- Do not store or use gasoline or other flammable vapors and liquids in the vicinity of this or any other appliance.
- **WHAT TO DO IF YOU SMELL GAS:**
 - Do not try to light any appliance.
 - Do not touch any electrical switch; do not use any phone in your building.
 - Immediately call your gas supplier from a neighbor's phone. Follow the gas supplier's instructions.
 - If you cannot reach your gas supplier, call the fire department.
- Installation and service must be performed by a qualified installer, service agency or the gas supplier.

AVERTISSEMENT : Assurez-vous de bien suivre les instructions données dans cette notice pour réduire au minimum le risque d'incendie ou d'explosion ou pour éviter tout dommage matériel, toute blessure ou la mort.

- Ne pas entreposer ni utiliser d'essence ni d'autres vapeurs ou liquides inflammables dans le voisinage de cet appareil ou de tout autre appareil.
- **QUE FAIRE SI VOUS SENTEZ UNE ODEUR DE GAZ :**
 - Ne pas tenter d'allumer d'appareil.
 - Ne touchez à aucun interrupteur. Ne pas vous servir des téléphones se trouvant dans le bâtiment où vous trouvez.
 - Appelez immédiatement votre fournisseur de gaz depuis un voisin. Suivez les instructions du fournisseur.
 - Si vous ne pouvez rejoindre le fournisseur de gaz, appelez le service des incendies.
- L'installation et l'entretien doivent être assurés par un installateur ou un service d'entretien qualifié ou par le fournisseur de gaz.

TABLE OF CONTENTS

Packaging	2
Introduction	2
Approved Vent Components	2
General Information	2
Misc. Codes/Standards	3
Inputs and Efficiencies	3
Gas Supply Pressure Requirements.....	3
Orifice Sizes	4
Gas Valve Diagram	4
Massachusetts / NYC Requirements	4
Cold Climate Insulation	5
Manufactured Home Requirements	5
Location	5
Vent Termination Clearances	6
Hearth Extensions (Optional)	8
Minimum Clearances to Combustibles.....	9
Pre-Installation Steps.....	10
Typical Installation Sequence	10
Detailed Installation Steps:	
Step 1. Framing.....	10
Framing Dimensions	11
Fireplace Specifications.....	12
Step 2. Route Gas Line	13
Step 3. Install Vent System	13
General Information	13
Vent Restrictor	14
Power Vent Components.....	14
Vent Section Lengths	15
Vertical (Offset) Installation.....	15
Vent Figures	17
Horizontal (Outside Wall) Termination System.....	18
Step 4. Field Wiring.....	20
Step 5. Remove Glass Door Assembly.....	22
Step 6. Connect Gas Line.....	23
Step 7. Install Firebox Liner Panels.....	23
Step 8. Verify Appliance Operation.....	23
Step 9. Install Volcanic Stone, Glowing Embers, and Logs	24
Step 10. Install Glass Doors, Mesh Pull Screens, and Modesty Panel	27
Step 11. Burner Adjustments	28
Finishing Requirements	29
Step 12. Attaching Safety-in-Operation	
Warnings	31
Installation Accessories	32
Gas Conversion Kits	33

PACKAGING

The assembled vented gas fireplace is packaged with the following items:

- **Fireplace Components:**
 - (1) Literature Kit (in envelope in firebox; contains *Care and Operation Instructions*, *Installation Instructions*, safety-in-operation warning labels, warranty)
 - (1) Remote Control Kit (in plastic bag in firebox; contains remote control, receiver)
 - (1) Log Set
 - (1) Vent Restrictor Assembly
 - (1) bag Glowing Embers
 - (4) bags Volcanic Stone
 - (1) ea. Door Modesty Shield
- **Power Vent Components:**
 - (1) ea. Power Vent Termination
 - (1) ea. Termination Adaptor
 - (1) ea. Horizontal Firestop Assembly
 - (1) ea. Vacuum Hose
 - (1) ea. 11/32" Hose Clamp
 - (1) ea. Strain Relief
 - (1) ea. Bushing
 - (4) ea. 1/4" Insulated Male Terminals
 - (2) ea. #10 Ring Terminals
- **Panel Kit** (sold separately; REQUIRED for all fireplace models) - one of the following kits:
 - Architectural Stone Ceramic
 - Venetian Tile Ceramic
 - Buff Herringbone Ceramic
 - Buff Rustic Ceramic
 - Black Rustic Ceramic
 - Black Porcelain
- **Outdoor Kit** (sold separately; REQUIRED for indoor/outdoor installations)

INTRODUCTION

The Montebello™ See-Through Power Vent is a direct-vent, sealed combustion gas fireplace designed for either **indoor/indoor** or **indoor/outdoor** residential applications (including screened porches and lanais).

NOTE: INDOOR/OUTDOOR INSTALLATIONS REQUIRE AN OUTDOOR INSTALLATION KIT (SOLD SEPARATELY).

These appliances are designed to operate on natural gas. (Propane units are available as a field conversion.) The system is switchable between standing and intermittent pilot modes.

External electrical power is required to operate these units.

Approved Vent Components

These fireplaces are designed, tested, and listed for operation and installation with the following vent components (4-1/2" inner and 7-1/2" outer) only:

- **Secure Vent™** direct-vent system components manufactured by Security Chimneys International.

These approved vent system components are labeled for identification. Do NOT use any other manufacturer's vent components with these appliances.

GENERAL INFORMATION

WARNING

Young children should be carefully supervised when they are in the same room as the appliance. Toddlers, young children and others may be susceptible to accidental contact burns. A physical barrier is recommended if there are at risk individuals in the house. To restrict access to a fireplace or stove, install an adjustable safety gate to keep toddlers, young children and other at risk individuals out of the room and away from hot surfaces.

AVERTISSEMENT

Les jeunes enfants devraient être surveillés étroitement lorsqu'ils se trouvent dans la même pièce que l'appareil. Les tout petits, les jeunes enfants ou les adultes peuvent subir des brûlures s'ils viennent en contact avec la surface chaude. Il est recommandé d'installer une barrière physique si des personnes à risques habitent la maison. Pour empêcher l'accès à un foyer ou à un poêle, installez une barrière de sécurité; cette mesure empêchera les tout petits, les jeunes enfants et toute autre personne à risque d'avoir accès à la pièce et aux surfaces chaudes.

Children and adults should be alerted to the hazards of high surface temperature and should stay away to avoid burns or clothing ignition.

Les enfants et les adultes devraient être informés des dangers que posent les températures de surface élevées et se tenir à distance afin d'éviter des brûlures ou que leurs vêtements ne s'enflamment.

DO NOT ATTEMPT TO ALTER OR MODIFY THE CONSTRUCTION OF THE APPLIANCE OR ITS COMPONENTS. ANY MODIFICATION OR ALTERATION MAY VOID THE WARRANTY, CERTIFICATION AND LISTINGS OF THIS UNIT.



We recommend that our gas hearth products be installed and serviced by professionals who are certified in the U.S. by the National Fireplace Institute® (NFI) as NFI Gas Specialists.

⚠ WARNING
 Improper installation, adjustment, alteration, service or maintenance can cause injury or property damage. Refer to this manual. For assistance or additional information consult a qualified installer, service agency or the gas supplier.

⚠ WARNING
 Failure to comply with these installation instructions will result in an improperly installed and operating appliance, voiding its warranty. Any change to this appliance and/or its operating controls is dangerous.

⚠ WARNING
 Clothing or other flammable material should not be placed on or near the appliance.

⚠ AVERTISSEMENT
 On ne devrait pas placer de vêtements ni d'autres matières inflammables sur l'appareil ni à proximité.

⚠ WARNING
 Any safety screen or guard removed for servicing the appliance must be replaced prior to operating the appliance.

⚠ AVERTISSEMENT
 Tout écran ou protecteur retiré pour permettre l'entretien de l'appareil doit être remis en place avant de mettre l'appareil en marche.

⚠ WARNING
 Improper installation or use of this appliance can cause serious injury or death from fire, burns, explosion or carbon monoxide poisoning.

Note: Installation and repair should be done by a qualified service person. The appliance should be inspected before use and at least annually by a professional service person. More frequent cleaning may be required due to excessive lint from carpeting, bedding material, etcetera. It is imperative that control compartments, burners and circulating air passageways of the appliance be kept clean.

Remarque : L'installation et la réparation devrait être confiées à un technicien qualifié. L'appareil devrait faire l'objet d'une inspection par un technicien professionnel avant d'être utilisé et au moins une fois l'an par la suite. Des nettoyages plus fréquents peuvent être nécessaires si les tapis, la literie, et cetera produisent une quantité importante de poussière. Il est essentiel que les compartiments abritant les commandes, les brûleurs et les conduits de circulation d'air de l'appareil soient tenus propres.

Do not use these appliances if any part has been under water. Immediately call a qualified, professional service technician to inspect the appliance and to replace any parts of the control system and any gas control which have been under water.

Ne pas utiliser cet appareil s'il a été plongé, même partiellement, dans l'eau. Appeler un technicien qualifié pour inspecter l'appareil et remplacer toute partie du système de commande et toute commande qui a été plongée dans l'eau.

Only trim kit(s) supplied by the manufacturer shall be used in the installation of this appliance.

Seules les trousse de garniture fournies par le fabricant doivent être utilisées pour l'installation de cet appareil.

These appliances comply with National Safety Standards and are tested and listed by Intertek (Report No. 100326550PRT-001) to ANSI Z21.88 (in Canada, CSA-2.33), and CAN/CGA-2.17-M91 (CSA P4.1) in both USA and Canada, as vented gas fireplace.

These appliances are listed by Intertek for installation in bedrooms, aftermarket mobile homes, and manufactured homes.

Misc. Codes/Standards

Installation must conform to local codes or, in the absence of local codes, with the *National Fuel Gas Code, ANSI Z223.1/NFPA 54 - latest edition* (in Canada, the current CAN/CSA-B149.1 installation code).

The appliance, when installed, must be electrically grounded and wired in accordance with local codes or, in the absence of local codes, with the *National Electrical Code, ANSI/NFPA 70 - latest edition*, or the *Canadian Electrical Code, CSA C22.1 - latest edition*.

Provide adequate clearances around air openings and adequate accessibility clearance for service and proper operation. Never obstruct the front or back openings of the appliance.

These appliances are designed to operate on natural or propane gas only (if field-converted to propane). The use of other fuels or combination of fuels will degrade the performance of this system and may be dangerous.

The system is switchable between standing and intermittent pilot modes. External electrical power is required to operate these units.

These models come standard with a remotely modulated gas valve. The included transmitter remotely controls flame appearance and heat output (manual gas valve adjustment is not possible).

Inputs and Efficiencies

Appliance BTU inputs are listed in **Table 1A**. Appliance efficiencies are listed in **Table 1B**.

INPUTS	
Gas Type (Fireplace Model)	Inputs
Natural Gas (LSM40ST-N-PV)	40,000 to 60,000 BTU/hr
Liquid Propane (LSM40ST-N-PV field-converted to LP)	43,500 to 56,000 BTU/hr

Table 1A

EFFICIENCIES		
Gas Type (Fireplace Model)	AFUE	EnerGuide
Natural Gas (LSM40ST-N-PV)	68%	62%

Table 1B

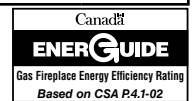

Gas Supply Pressure Requirements

Inlet and manifold gas supply pressure requirements for these appliances are listed in **Tables 2 and 3**.

Inlet Gas Supply Pressure (all models)		
Fuel #	Minimum	Maximum
Natural Gas	5.0" WC (1.24 kPa)	10.5" WC (2.61 kPa)
Liquid Propane*	11.0" WC (2.74 kPa)	13.0" WC (3.23 kPa)

Table 2 *Available as field conversion only.

Manifold Gas Supply Pressure (all models)		
Fuel #	Low	High
Natural Gas	(Lo) 1.6" WC (0.4 kPa)	(Hi) 3.5" WC (0.87 kPa)
Liquid Propane*	(Lo) 6.3" WC (1.57 kPa)	(Hi) 10.0" WC (2.49 kPa)

Table 3 *Available as field conversion only.

(Continued on next page)

Gas Supply Pressure Requirements

(continued from previous page)

Test gauge connections are provided on the front of the electronic gas control valve (identified **IN** for the inlet and **OUT** for the manifold side).

The control valves have a 3/8" (10 mm) NPT thread inlet and outlet side of the valve. Refer to **Figure 1**.

Propane tanks are at pressures that will cause damage to valve components. Verify that the tanks have step-down regulators to reduce the pressure to safe levels.

These appliances must not be connected to a chimney or flue serving a separate solid fuel burning appliance.

These appliances must be isolated from the gas supply piping system (by closing their individual manual shut-off valve) during any pressure testing of the gas supply piping system at test pressures equal to or **less than 1/2 psig (3.5 kPa)**.

These appliances and their individual shut-off valves must be disconnected from the gas supply piping system during any pressure testing of that system at pressures **greater than 1/2 psig (3.5 kPa)**.

PURGE CYCLE

This is a power-vented fireplace that requires household electrical power to operate. When the fireplace is turned OFF, the exhaust blower will continue to operate for up to two minutes, to purge exhaust gases from the venting system. This system will not operate during a power outage.

Orifice Sizes

Sea Level To High Altitude (All Models)

These appliances are tested and approved for installation at elevations of 0–4500 feet (0–1372 meters) above sea level using the standard burner orifice sizes listed in **Table 4**. For elevations above 4500 feet, contact your gas supplier or qualified service technician.

Deration

At higher elevations, the amount of BTU fuel value delivered must be reduced by either:

- using gas that has been derated by the gas company; or
- changing the burner orifice to a smaller size as regulated by the local authorities having jurisdiction and by the (USA) National Fuel Gas Code NFPA 54/ANSI Z223.1 - latest edition or, in Canada, the CAN/CSA-B149.1 codes - latest edition.

Install the appliance according to the regulations of the local authorities having jurisdiction and, in the USA, the National Fuel Gas Code NFPA 54 / ANSI Z223.1 - latest edition or, in Canada, the CAN/CSA-B149.1- latest edition.

NOTE: Flame appearance will diminish 4% per 1,000 feet.

Gas Valve Diagram

The SIT Proflame valve is illustrated in **Figure 1**.

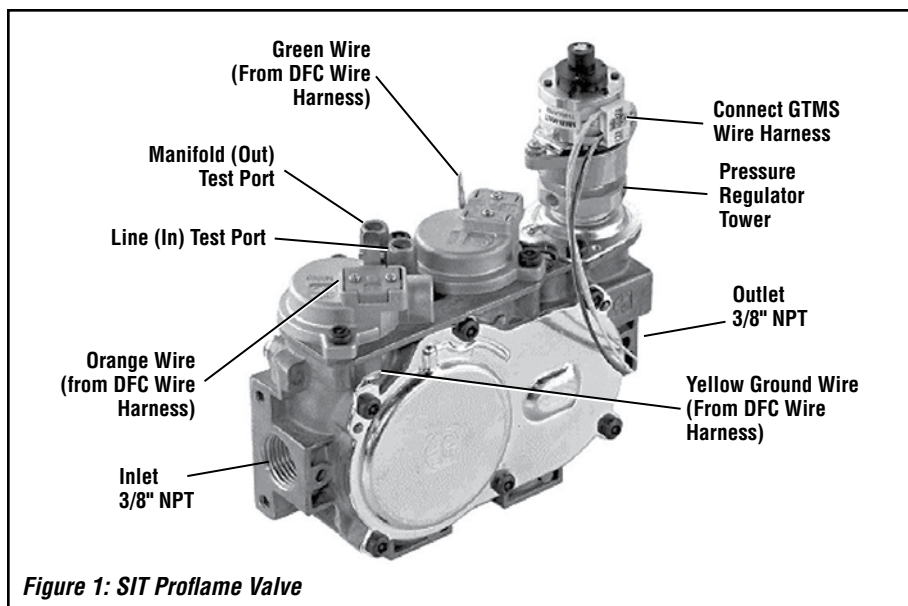

Figure 1: SIT Proflame Valve

Burner Orifice Sizes

(USA and Canada)

Elevation 0-4500 ft (0-1372 m)

Natural Gas Drill size (inches)	Propane Drill size (inches)
#32 (0.116") ① [Cat. No. H8002]	#52 (0.0635") ② [Cat. No. H8003]

① Standard size installed at factory.
② Standard size in LP conversion kit.

Table 4

Requirements for the Commonwealth of Massachusetts

These fireplaces are approved for installation in the US state of Massachusetts if the following additional requirements are met:

- Install this appliance in accordance with Massachusetts Rules and Regulations 248 C.M.R.
- Installation and repair must be done by a plumber or gas fitter licensed in the Commonwealth of Massachusetts.
- The flexible gas line connector used shall not exceed 36 inches (92 centimeters) in length.
- The individual manual shut-off must be a T-handle type valve.

Massachusetts Horizontal Vent Requirements

In the Commonwealth of Massachusetts, horizontal terminations installed less than seven (7) feet above the finished grade must comply with the following additional requirements:

- A hard-wired carbon monoxide detector with an alarm and battery backup must be installed on the floor level where the gas fireplace is installed. The carbon monoxide detector must comply with NFPA 720, be ANSI/UL 2034 listed and be ISA certified.
- A metal or plastic identification plate must be permanently mounted to the exterior of the building at a minimum height of eight (8) feet above grade and be directly in line with the horizontal termination. The sign must read, in print size no less than one-half (1/2) inch in size, **GAS VENT DIRECTLY BELOW. KEEP CLEAR OF ALL OBSTRUCTIONS.**

New York City, New York (MEA)

Installation of these fireplaces is approved for installation in New York City, NY.

COLD CLIMATE INSULATION

For cold climate installations, seal all cracks around the appliance with noncombustible material and wherever cold air could enter the room. If the floor is above ground level, it is especially important to insulate outside chase cavity between studs and under the floor on which the appliance rests. Gas line holes and other openings should be caulked or stuffed with unfaced fiberglass insulation.

If the fireplace is being installed on a cement slab in cold climates, a sheet of plywood or other raised platform can be placed underneath to prevent cold transfer to the fireplace and into the room. It also helps to sheetrock inside surfaces and tape for maximum air tightness and caulk firestops.

MANUFACTURED HOME REQUIREMENTS

This appliance may be installed in an after-market, permanently located manufactured home and must be installed in accordance with the manufacturer's instructions and the Manufactured Home Construction and Safety Standard, Title 24 CFR, Part 3280, in the United States, or the Standard for Installation in Mobile Homes, CAN/CSA Z240 MH Series, in Canada.

Cet appareil peut être installé comme du matériel d'origine dans une maison préfabriquée (É.U. seulement) ou mobile et doit être installé selon les instructions du fabricant et conformément à la norme Manufactured Home Constructions and Safety, Title 24 CFR, Part 3200 aux Unis ou à la norme Can/CSA-Z240 Série MM, Maisons mobiles au Canada.

This appliance is only for use with the type of gas indicated on the rating plate. This appliance is not convertible for use with other gases, unless a certified kit is used.

Cet appareil doit être utilisé uniquement avec le type de gaz indiqué sur la plaque signalétique. Cet appareil ne peut être converti à d'autres gaz, sauf si une trousse de conversion est utilisée.

CAUTION: Ensure that the cross members are not cut or weakened during installation. The structural integrity of the manufactured home floor, wall, and ceiling / roof must be maintained.

CAUTION: This appliance must be grounded to the chassis of the manufactured home in accordance with local codes or in the absence of local codes, with the National Electrical Code ANSI / NFPA 70 - latest edition or the Canadian Electrical Code CSA C22.1 - latest edition.

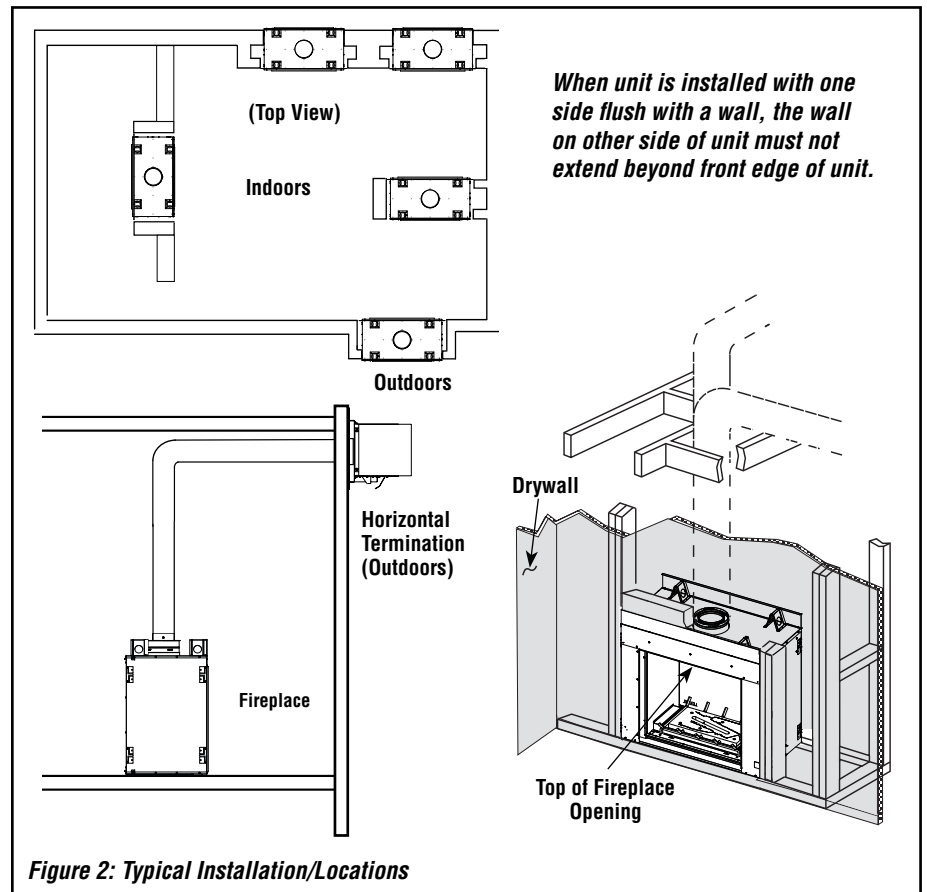

Figure 2: Typical Installation/Locations

LOCATION

In selecting the location, the aesthetic and functional use of the appliance are primary concerns; however, vent system routing to the exterior and access to the fuel supply are also important.

CAUTION: Due to high temperatures, the appliance should be located out of traffic and away from furniture and draperies (Figure 2).

AVERTISSEMENT : En raison des températures élevées, l'appareil devrait être installé dans un endroit où il y a peu de circulation et loin du mobilier et des tentures (Figure 2).

The location also should be free of electrical, plumbing, or other heating/air conditioning ducting.

These direct-vent appliances are uniquely suited for installations requiring a utility shelf positioned above the fireplace. Utility shelves like these are commonly used for locating television sets and decorative plants.

The minimum height from the base of the appliance to the underside of combustible materials used to construct a utility shelf in this fashion is shown in *Figure 7 on Page 9*.

Be aware that this is a heat-producing appliance. Objects placed above the unit are exposed to elevated temperatures.

Do not insulate the space between the appliance and the area above it.

The appliance should be mounted on a fully supported base extending the full width and depth of the unit. The appliance may be located on or near conventional construction materials. However, if installed on combustible materials, (such as carpeting or vinyl tile), a metal or wood barrier covering the entire bottom surface must be used.

VENT TERMINATION CLEARANCES

These instructions should be used as a guideline and do not supersede local codes in any way. Install venting according to local codes, these instructions, the current National Fuel Gas Code (ANSI-Z223.1) in the USA or the current standards of CAN/CSA-B149.1 in Canada. When planning your vent run refer to the table in *Figure 22 on Page 17*.

Horizontal Vent Termination Clearances

The horizontal vent termination must have a minimum of 3" (76 mm) clearance to any overhead combustible projection of 2-1/2" (64 mm) or less (see *Figure 3*). For projections exceeding 2-1/2" (64 mm), see *Figure 3*. For additional vent location restrictions refer to *Figure 4 on Page 7*.

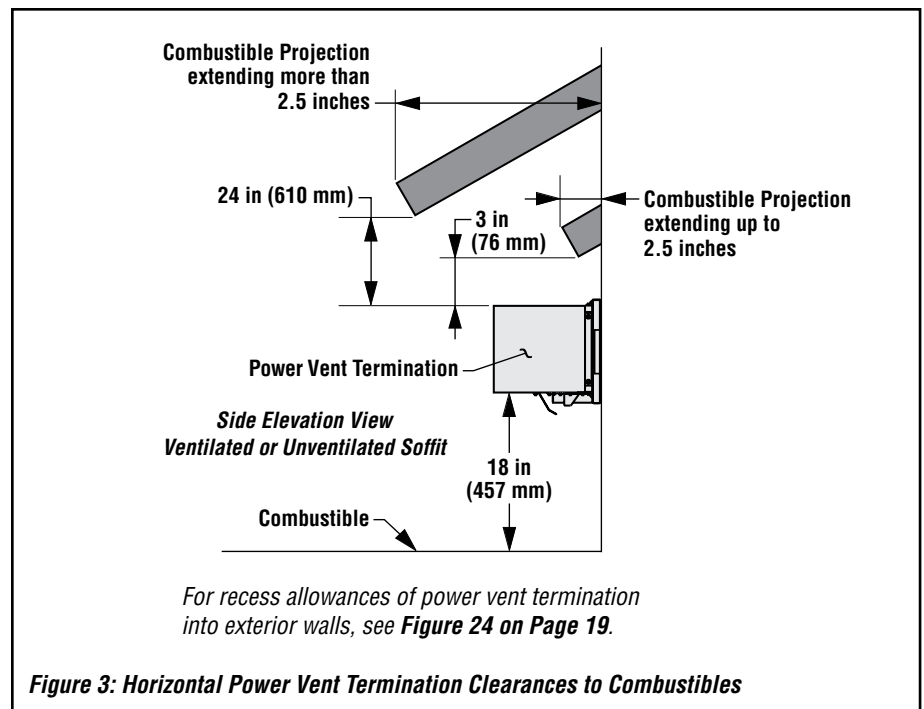

EXTERIOR HORIZONTAL VENT TERMINATION CLEARANCE REQUIREMENTS

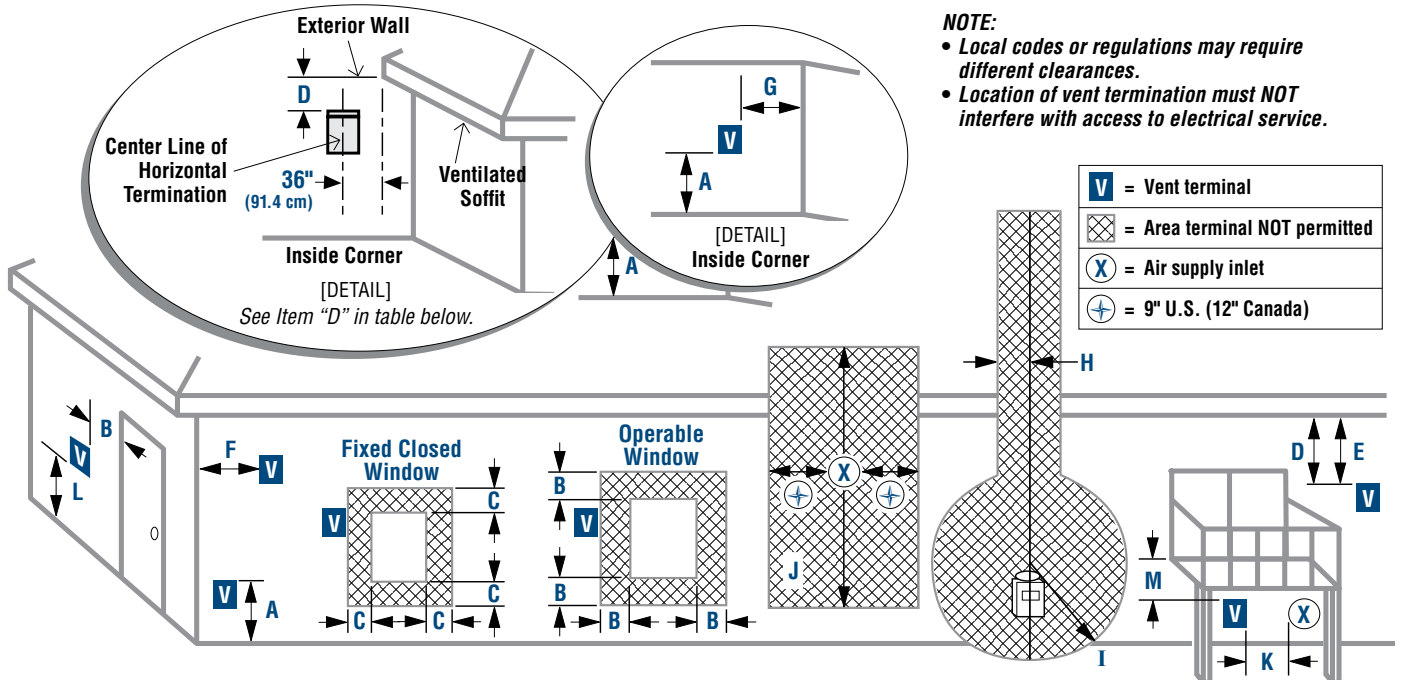

NOTE:
 • Local codes or regulations may require different clearances.
 • Location of vent termination must NOT interfere with access to electrical service.

V = Vent terminal
= Area terminal NOT permitted
X = Air supply inlet
= 9" U.S. (12" Canada)

MINIMUM CLEARANCES		
Clearance Description	US Installation ①	Canadian Installation ②
A = Clearance above grade, veranda, porch, deck, or balcony.	18 in (46 cm) ①	18 in (46 cm) ②
B = Clearance to window or door that may be opened.	6 in (15.2 cm) for appliances < 10,000 BTU/hr (3kW); 9 in (23 cm) for appliances > 10,000 BTU/hr (3kW) and < 50,000 BTU/hr (15kW); 12 in (30 cm) for appliances > 50,000 BTU/hr (15kW). ①	6 in (15.2 cm) for appliances < 10,000 BTU/hr (3kW); 12 in (30 cm) for appliances > 10,000 BTU/hr (3kW) and < 100,000 BTU/hr (30kW); 36 in (91.4 cm) for appliances > 100,000 BTU/hr (30kW). ②
C = Clearance to permanently closed window.	9 in (229 mm) recommended to prevent window condensation.	12 in (305 mm) recommended to prevent window condensation.
D = Vertical clearance to ventilated soffit located above the terminal within a horizontal distance of 36 in (91.4 cm) from center line of terminal.	24 in (61 cm)	24 in (61 cm)
E = Clearance to unventilated soffit.	24 in (61 cm)	24 in (61 cm)
F = Clearance to outside corner.	5 in (12.7 cm)	5 in (12.7 cm)
G = Clearance to inside corner.	24 in (61 cm)	36 in (91.4 cm)
H = Clearance to each inside of center line extended above meter/regulator assembly.	3 ft (91.4 cm) within a height of 15 ft above the meter/regulator assembly. ①	3 ft (91.4 cm) within a height of 15 ft above the meter/regulator assembly. ②
I = Clearance to service regulator vent outlet.	3 ft (91.4 cm) ①	3 ft (91.4 cm) ②
J = Clearance to non-mechanical air supply inlet to building or combustion air inlet to any other appliance.	6 in (15.2 cm) for appliances < 10,000 BTU/hr (3kW); 9 in (23 cm) for appliances > 10,000 BTU/hr (3kW) and < 50,000 BTU/hr (15kW); 12 in (30 cm) for appliances > 50,000 BTU/hr (15kW). ①	6 in (15.2 cm) for appliances < 10,000 BTU/hr (3kW); 12 in (30 cm) for appliances > 10,000 BTU/hr (3kW) and < 100,000 BTU/hr (30kW); 36 in (91.4 cm) for appliances > 100,000 BTU/hr (30kW). ②
K = Clearance to mechanical air supply inlet.	3 ft (91.4 cm) above, if within 10 ft (3 m) horizontally. ①	6 ft (1.83 m) ②
L = Clearance above paved sidewalk or paved driveway located on public property.	7 ft (2.13 m) ③	7 ft (2.13 m) ③
M = Clearance under veranda, porch, deck, or balcony.	18 in (46.0 cm) ① ③	18 in (46.0 cm) ④

① In accordance with the current ANSI Z223.1 / NFPA 54 National Fuel Codes (latest editions).
 ② In accordance with the current CAN/CSA-B149.1 Installation Code (latest editions).
 ③ A vent shall not terminate directly above a sidewalk or paved driveway that is located between two single-family dwellings and serves both dwellings.
 ④ Only permitted if veranda, porch, deck, or balcony is fully open on a minimum of two sides beneath the floor.

Figure 4

HEARTH EXTENSIONS (OPTIONAL)

Note: *Hearth extensions are not required with this appliance.*

Optional Indoor Hearth Extension

Combustible indoor hearth material may only be installed **at or below** the base of the fireplace (see **Figures 5 and 6**).

Non-combustible indoor hearth material may be installed above the base of the fireplace and may butt against the front face of the fireplace (see **Figures 5 and 6**).

Also note the following:

- Combustible material may project beyond the sides of the fireplace opening, as long as it is within the shaded area shown in **Figure 9 on Page 9**.
- Vertical installation clearances to combustible mantels vary according to the depth of the mantel (see **Figure 8 on Page 9**).
- Non-combustible mantels may be installed at any height above the appliance opening.

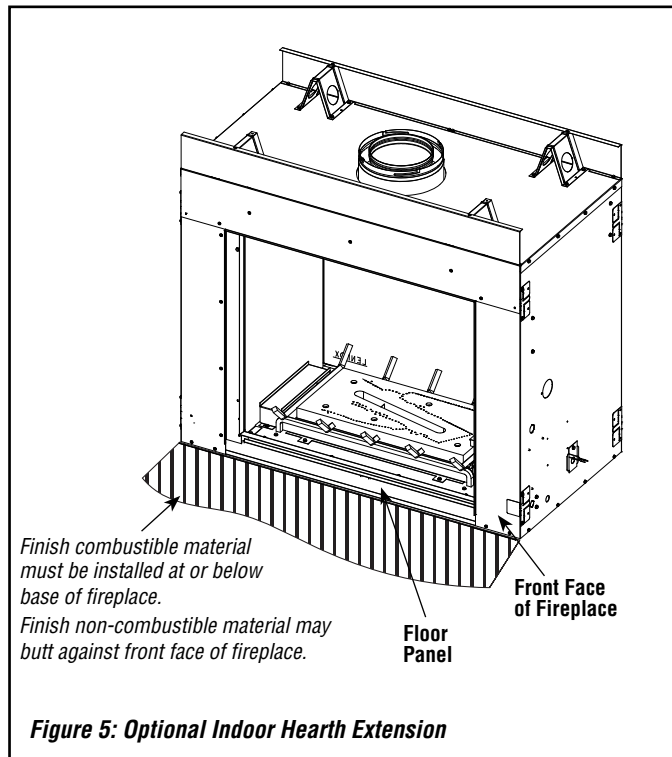

Optional Outdoor Hearth Extension

All outdoor hearth material (combustible and non-combustible) must be installed a **minimum of 6" (152 mm)** below the base of the fireplace (see **Figure 6**).

Also note the following:

- For vertical installation clearances to combustible outdoor mantels and overhangs, see **Page 30** and the instructions provided in the Outdoor Installation Kit (required for all outdoor installations; see **Page 32**).
- Non-combustible outdoor mantels and overhangs may be installed at any height above the appliance opening.

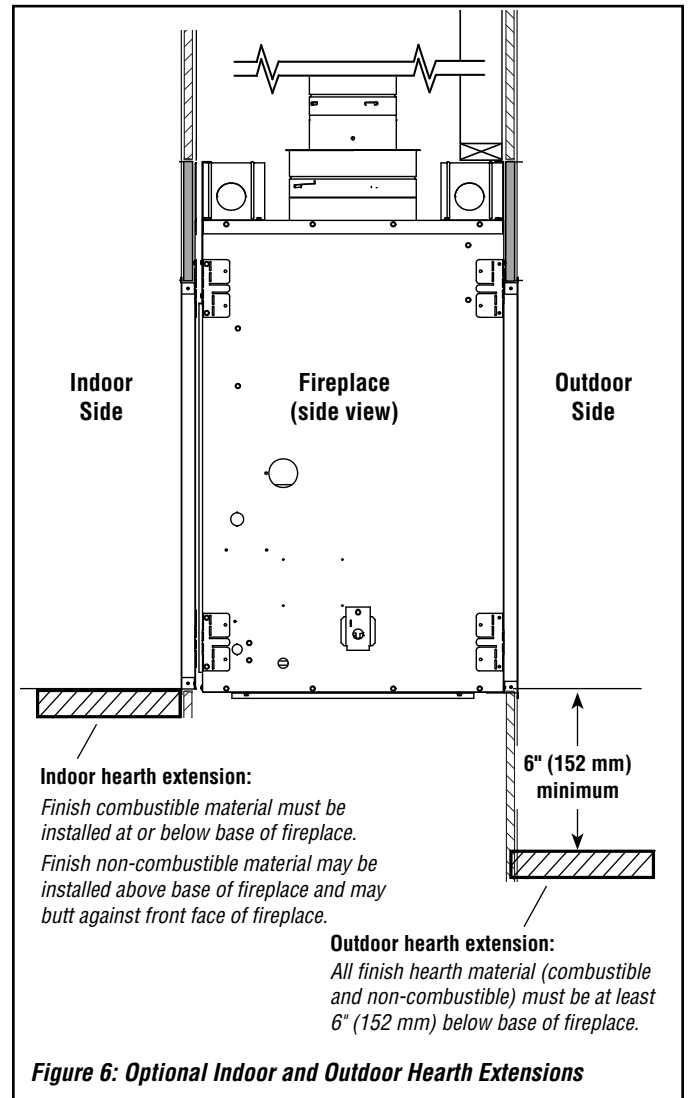

MINIMUM CLEARANCES TO COMBUSTIBLES

Appliance and Vent Clearances

The appliance is approved with zero clearance to combustible materials on both sides (as detailed in **Table 5**), with the following exceptions:

- When the unit is installed with one side flush with a wall, the wall on the other side of the unit must not extend beyond the front edge of the unit.
- In addition, when the unit is recessed, the side walls surrounding the unit must not extend beyond the front edge of the unit (see **Figure 2** on **Page 5**).

MINIMUM CLEARANCES TO COMBUSTIBLES ①	
Back / Sides	0 in (0 mm) Spacers ②
Top Spacers	0 in (0 mm)
Floor	0 in (0 mm)
Unit Bottom to Ceiling	72.0 in (1829 mm)
Vertical Vent Pipe	1.0 in (25.4 mm)
Horizontal Vent Pipe	Top: 3.0 in (76.2 mm) Sides: 1.0 in (25.4 mm) Bottom: 1.0 in (25.4 mm)
SERVICE CLEARANCES	
Front	3 ft (0.9 m)

Table 5

- ① 3" (76 mm) above any horizontal/inclined vent component.
 ② See **Step 1 ("FRAMING")** on **Page 10** for clearance requirements to the nailing flanges on each side of the unit and any adjacent screw heads.

The appliance should be mounted on a fully supported base extending the full width and depth of the unit. The appliance may be located on or near conventional construction materials; however, if installed on combustible materials, such as carpeting, vinyl tile, etc., a metal or wood barrier covering the entire bottom surface must be used.

Min. Height of Combustible Enclosure

To provide for the lowest possible combustible enclosure (or shelf) surface, the venting should be routed in a way to minimize obstructions to the space above the appliance. Do not insulate the space between the appliance and the area above it (see **Figure 7**).

Wall Finishes / Surrounds / Mantels

Note: Combustible wall finish materials and/or surround materials must not be allowed to encroach the area defined by the appliance front faces (black sheet metal). Never allow combustible materials to be positioned in front of or overlapping the appliance face. See **Pages 29 and 30**.

Non-combustible materials, such as surrounds and other appliance trim, may be installed on the appliance front face only if they do NOT cover any portion of the removable glass panel.

Vertical installation clearances to combustible mantels vary according to the depth of the mantel. See **Figure 8**. Mantels constructed of non-combustible materials may be installed at any height above the appliance opening.

Note: Use high-temperature paint (rated 175°F or higher) on the underside of the mantel.

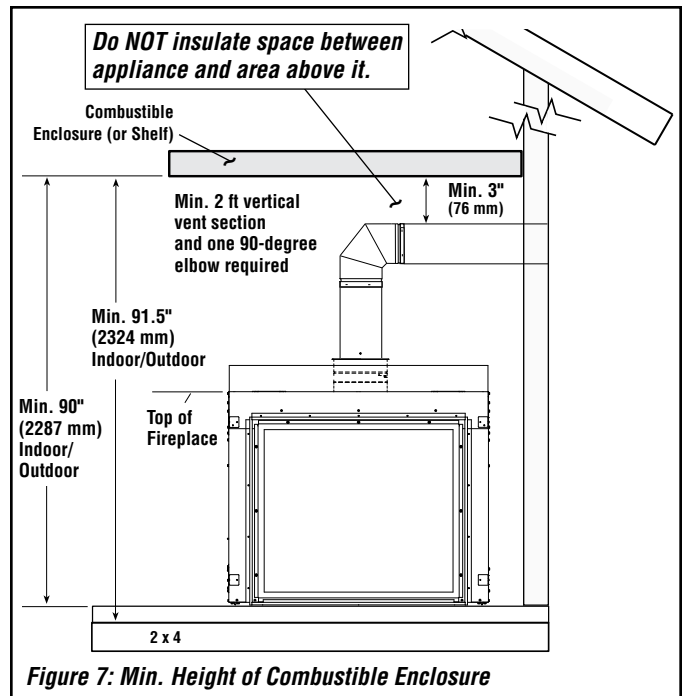

Figure 7: Min. Height of Combustible Enclosure

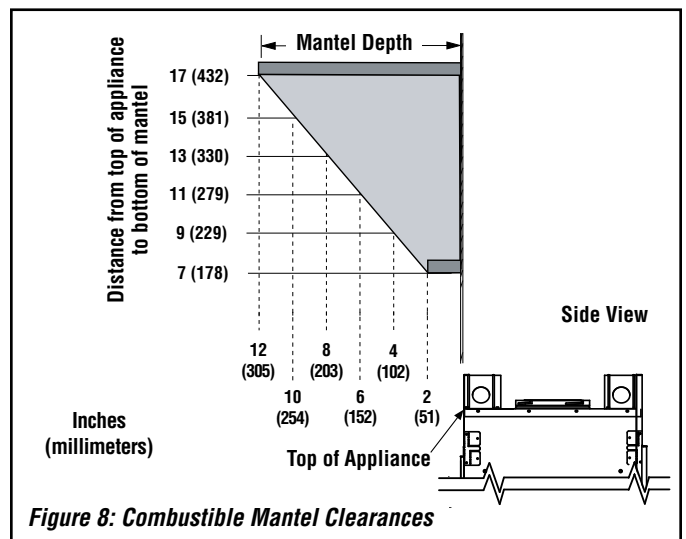

Figure 8: Combustible Mantel Clearances

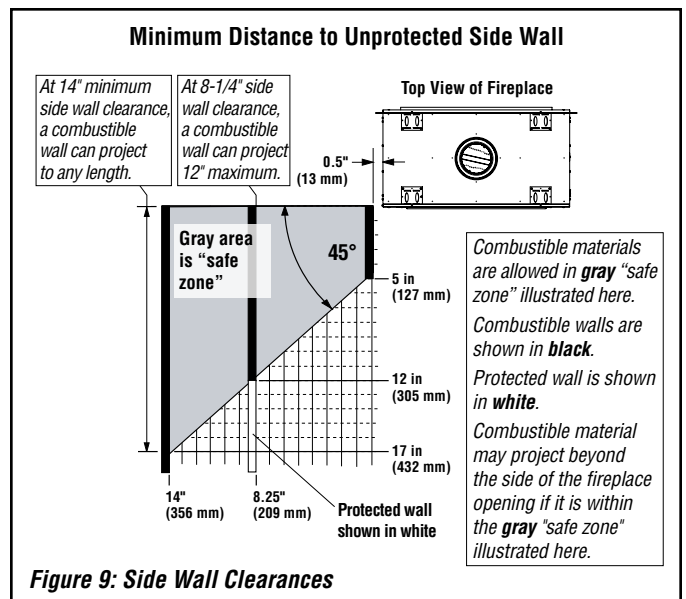

Figure 9: Side Wall Clearances

PRE-INSTALLATION STEPS

The appliance is shipped with all gas controls and components installed and pre-wired.

1. Remove the shipping carton, exposing the glass door on the control side.
2. Remove glass door assembly (see detailed instructions on **Page 27**).

! WARNING

Failure to position the parts in accordance with these diagrams or failure to use only parts specifically approved with this appliance may result in property damage or personal injury.

! AVERTISSEMENT

Risque de dommages ou de blessures si les pièces ne sont pas installées conformément à ces schémas et ou si des pièces autres que celles spécifiquement approuvées avec cet appareil sont utilisées.

TYPICAL INSTALLATION SEQUENCE

The typical sequence of installation is outlined below.

Note: Each installation is unique and may result in variations to the steps described herein.

See the page numbers referenced in the following steps for detailed procedures.

- Step 1. FRAMING (Page 10):** Construct appliance framing. Position appliance within framing, and secure with nailing brackets.
- Step 2. ROUTE GAS LINE (Page 13):** Route gas supply line to right side (when viewed from control side of appliance).
- Step 3. INSTALL VENT SYSTEM (Page 13):** install vent system and exterior termination.
- Step 4. FIELD WIRING (Page 20):** Connect 120 Vac electrical power to the appliance receptacle.
- Step 5. REMOVE GLASS DOOR ASSEMBLY (Page 22).**
- Step 6. CONNECT GAS LINE (Page 23):** Make connection to gas supply.
- Step 7. INSTALL FIREBOX LINER PANELS (Page 23).**
- Step 8. VERIFY APPLIANCE OPERATION (Page 23).**
- Step 9. INSTALL VOLCANIC STONE, GLOWING EMBERS, AND LOGS (Page 24).**
- Step 10. INSTALL GLASS DOORS, MESH PULL SCREENS, AND MODESTY PANEL (Page 27).**
- Step 11. BURNER ADJUSTMENTS (Page 28):** Adjust burner air shutter to ensure proper flame appearance.

FINISHING REQUIREMENTS (Page 29).

- Step 12. ATTACH SAFETY-IN-OPERATION WARNINGS (Page 31).**

DETAILED INSTALLATION STEPS

Step 1. FRAMING

Frame these appliances as illustrated on **Page 11**. All framing details must allow for a minimum clearance to combustible framing members as shown on **Page 9**.

If the appliance is to be elevated above floor level, a solid continuous platform must be constructed below the appliance.

Headers may be in direct contact with the appliance top spacers, but must not be supported by them or notched to fit around them. All construction above the appliance must be self-supporting; **DO NOT** use the appliance for structural support.

Secure the fireplace to the side framing members using the unit's nailing flanges — one top and bottom on each side of the fireplace front (see **Figure 10**). Use 8d nails or their equivalent.

Securing Unit to Framing by Nailing Flanges

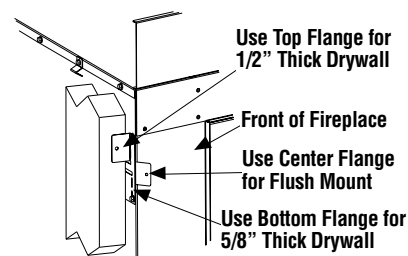

Left Side Front Corner of Fireplace Shown (Same requirements for right side)

Note: The nailing flanges, combustible members and screw heads in areas directly adjacent to the nailing flanges are EXEMPT from the 1/2-inch clearance to combustible requirements for the firebox outer wrapper. Combustible framing may be in direct contact with the nailing flanges and may be located closer than 1/2 inch from screw heads and the firebox wrapper in areas adjacent to the nailing flanges. Frame the opening to the exact dimensions specified in the framing details of the **Installation Instructions**.

Figure 10

FRAMING DIMENSIONS: Montebello See-Through Power Vent

Framing should be constructions of 2x4 or larger lumber.

LSM40ST-PV	A	B ①	C ②	D	E ④
in	52-1/16	47-5/16	99-1/2	26-5/16	6
(mm)	(1322)	(1202)	(2527)	(668)	(152)

- ① Dimension **B** is from fireplace base to top framing member.
- ② Dimension **C** is from fireplace base to centerline of horizontal vent pipe.
Minimum vent framing: Adaptor plus 4 ft vertical vent and one 90-degree elbow.
For other venting configurations, see **Step 3, INSTALL VENTING SYSTEM.**
- ③ 1/2-inch board for platform (shown in gray).
- ④ Dimension **E** is a 6-inch clearance from fireplace base to outdoor surface (e.g., deck, patio, lanai) that is required as a moisture barrier (not a combustible clearance) on outdoor side only.

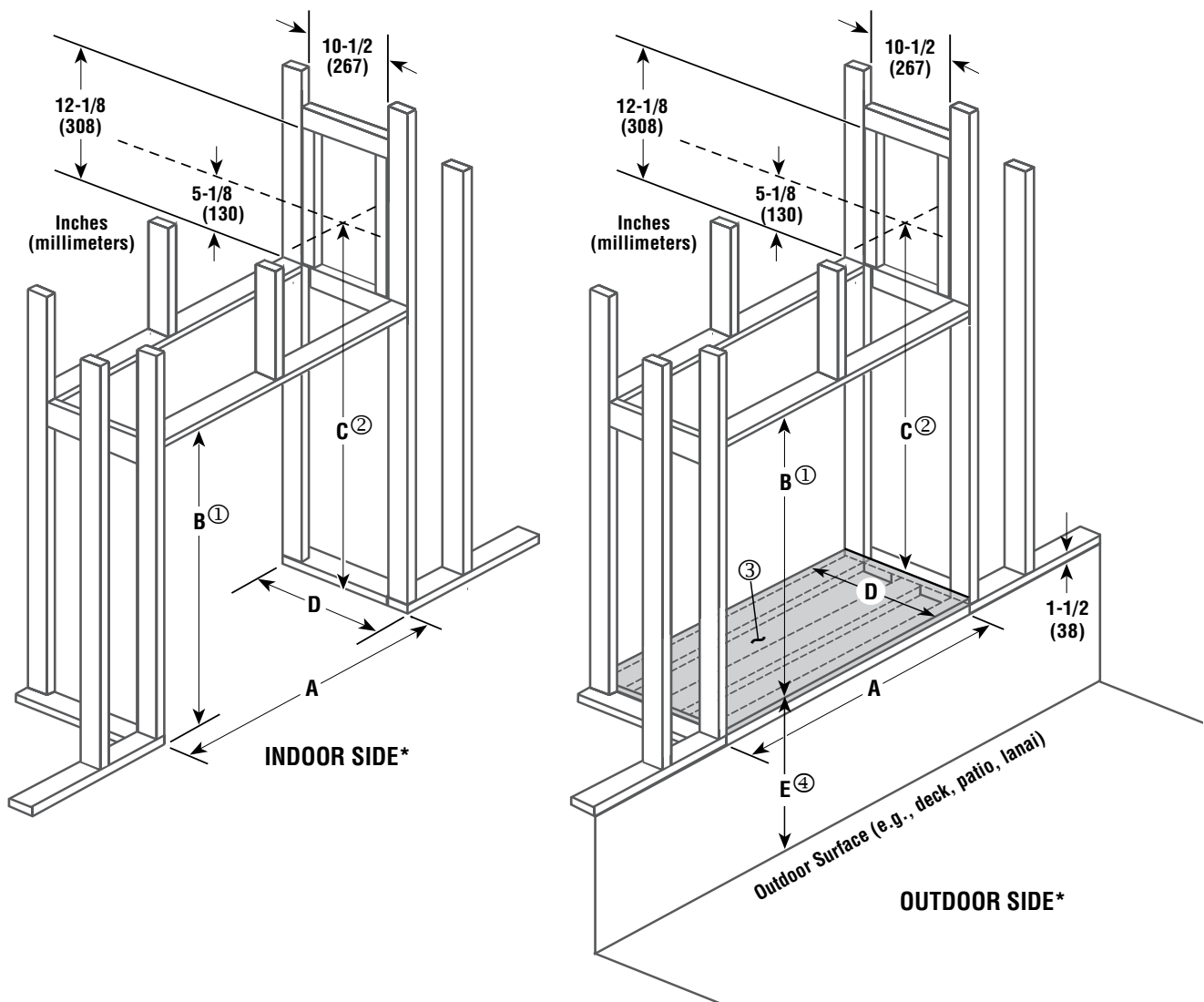
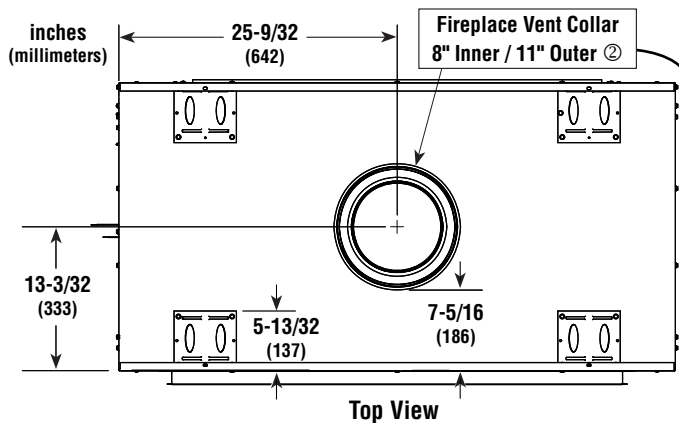
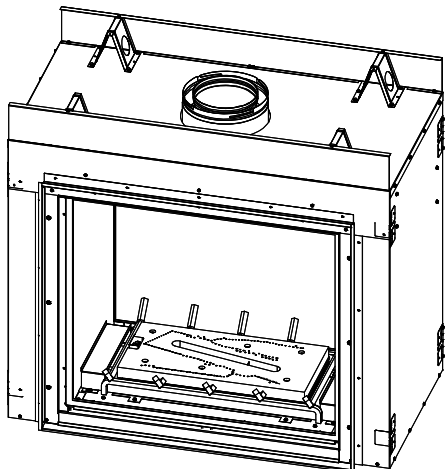

Figure 11

*For indoor/outdoor installations, the control side of the fireplace must be installed on the indoor side.

FIREPLACE SPECIFICATIONS: Montebello See-Through Power Vent



FIREPLACE COLLAR AND VENT SIZES	
Fireplace Vent Collar (Coaxial DV)	8" Inner / 11" Outer ②
Vent Pipe (Coaxial DV)	4-1/2" Inner / 7-1/2" Outer ②

② Adaptor/Probe assembly (cat. no. H8313) required to transition from fireplace vent collar to vent pipe.

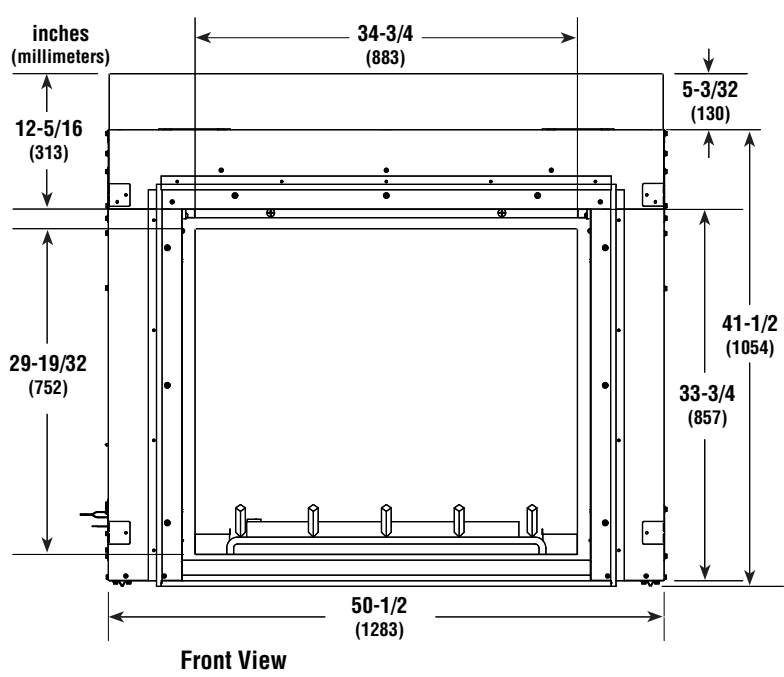
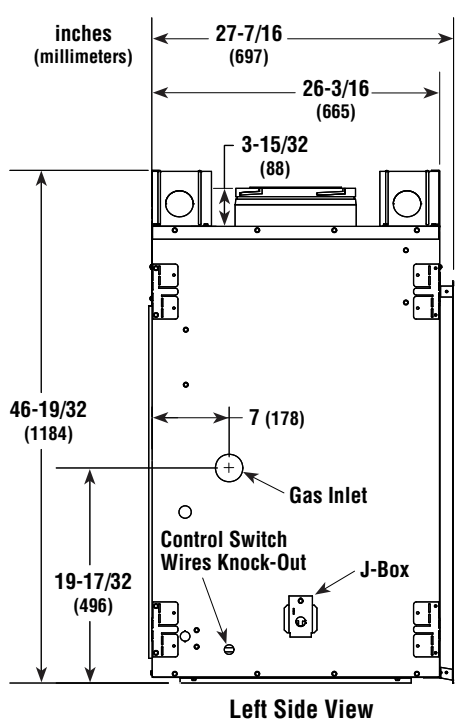

Fireplace Dimensions
(shown with Outdoor Kit installed)

Figure 12

Step 2. ROUTE GAS LINE

▲ NOTICE: For indoor/outdoor installations, the **CONTROL SIDE** of the fireplace must be installed on the **INDOOR** side.

Route a 1/2" (13 mm) gas line along the inside of the right side framing as shown in **Figures 13 and 14**. Gas lines must be routed, constructed and made of materials that are in strict accordance with local codes and regulations.

All appliances are factory-equipped with a flexible gas line connector and 1/2 inch shutoff valve (**see Step 6 on Page 23**).

The incoming gas line should be piped into the valve compartment and connected in one of the two methods as shown in **Figure 35 on Page 23**.

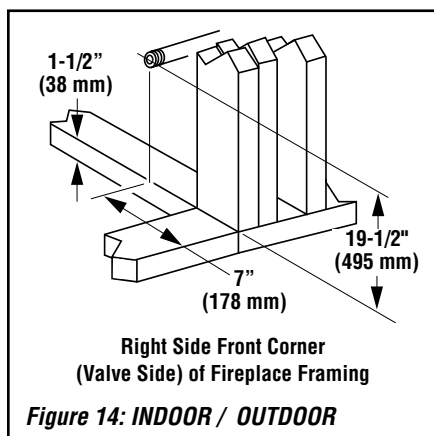
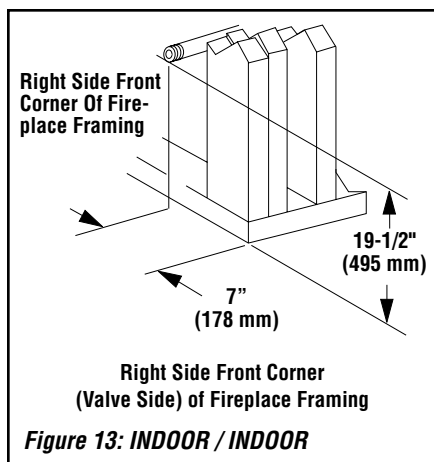

Schedule 40, Black Iron Pipe Inside Diameter (Inches)		
Schedule 40 Pipe Length (feet)	Natural Gas	Propane Gas
0-10	1/2	3/8
10-40	1/2	1/2
40-100	1/2	1/2
100-150	3/4	1/2
150-200	3/4	1/2

Table 6

Proper Sizing of Gas Line

Properly size and route the gas supply line from the supply regulator to the area where the appliance is to be installed per requirements outlined in the National Fuel Gas Code, NFPA 54 - latest edition (USA) or CAN/CSA-B149.1 - latest edition (Canada).

IMPORTANT: It is critical that a licensed installer perform this step strictly per NFPA.

Never use galvanized or plastic pipe. Refer to **Table 6** for proper sizing of the gas supply line, if black iron pipe is being used. Gas lines must be routed, constructed and made of materials that are in strict accordance with local codes and regulations. We recommend that a qualified individual such as a plumber or gas fitter be hired to correctly size and route the gas supply line to the appliance. Installing a gas supply line from the fuel supply to the appliance involves numerous considerations of materials, protection, sizing, locations, controls, pressure, sediment, and more. Certainly no one unfamiliar and unqualified should attempt sizing or installing gas piping.

Note:

- All appliances are factory-equipped with a flexible gas line connector and 1/2 inch shutoff valve (**see Figure 35 on Page 23**).
- See **Massachusetts Requirements on Page 4** for additional requirements for installations in the state of Massachusetts in the USA.
- The gas supply line should not be connected to the appliance until **Step 6 (Page 23)**.
- A pipe joint compound rated for gas should be used on the threaded joints. **Ensure propane resistant compounds are used in propane applications.** Be very careful that the pipe compound does not get inside the pipe.
- It is recommended to install a sediment trap in the supply line as close as possible to the appliance (**see Figure 35 on Page 23**). Appliances using Propane should have a sediment trap at the base of the tank.
- Check with local building official for local code requirements (i.e. are below grade penetrations of the gas line allowed?, etc).

IMPORTANT NOTE REGARDING PROPANE INSTALLATIONS

Using a propane tank smaller than 100 lbs may create pressure loss and insufficient fuel delivery, which can cause sooting, severe delayed ignition, or other malfunctions (ref. NPFA 58).

Any damage as a result of insufficient tank size or other improper installation is NOT covered under the limited warranty.

Step 3. INSTALL VENT SYSTEM

General Information

These instructions should be used as a guide-line and do not supersede local codes in any way. Install venting according to local codes, these instructions, the current National Fuel Gas Code (ANSI-Z223.1) in the USA or the current standards of CAN/CGA-B149.1 and -B149.2 in Canada.

These fireplaces are designed, tested and listed for operation and installation with, and only with, Secure Vent™ (SV4.5) Direct-Vent System Components, manufactured by Security Chimneys International. These approved vent system components are labeled for identification. **DO NOT** use any other manufacturer's vent components with these appliances.

Ensure clearances are in accordance with local installation codes and the requirements of the gas supplier.

Dégagement conforme aux codes d'installation locaux et aux exigences du fournisseur gaz.

Use only approved venting components. See **Approved Vent Components on Page 2**.

These fireplaces must be vented directly to the outside.

The vent system may not service multiple appliances, and must never be connected to a flue serving a solid fuel burning appliance. The vent pipe is tested to be run inside an enclosed wall (such as a chase). There is no requirement for inspection openings in the enclosing wall at any of the joints in the vent pipe.

Venting System

With the appliance secured in framing, determine vent routing and identify the exterior termination location. The following sections describe horizontal (exterior wall) vent applications. **A list of approved venting components is shown on Page 32.**

Vent Restrictor

The adaptor/probe assembly for this appliance has a pre-installed vent restrictor with a 1-3/4" hole in the center (see **Figure 15**). This pre-installed vent restrictor is **not** for use with any venting configuration for this fireplace model and must be replaced with one of the two provided vent restrictors, as described below.

Vent Restrictor Size Guidelines

- For venting systems **30 ft in length or less**, replace the factory installed vent restrictor with the provided vent restrictor with a **1-5/8" dia. hole**.
- For venting systems **greater than 30 ft in length**, replace the factory installed vent restrictor with the provided vent restrictor with a **2-1/4" dia. hole**.

Vent Restrictor Installation Instructions

Install the appropriate vent restrictor (as described above) into the adaptor/probe assembly per the instructions in **Figure 15**.

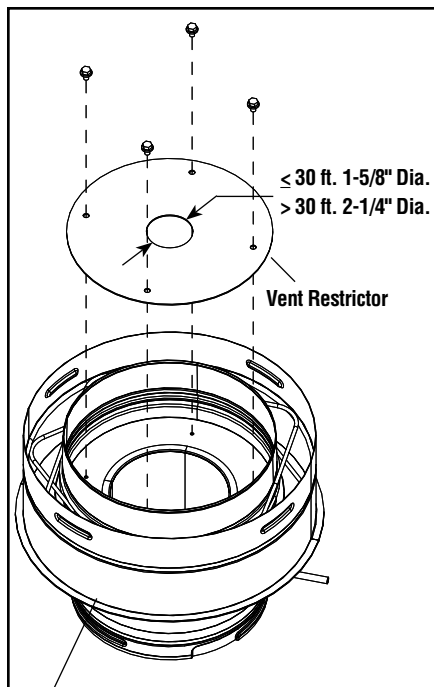

Adaptor/Probe Assembly (shown upside-down)

Vent Restrictor Installation Instructions

1. Turn the adaptor/probe assembly upside-down, as shown.
2. Remove the four screws securing the vent restrictor in place. Lift out the vent restrictor.
3. Install the appropriate vent restrictor, using the four screws previously removed. See "**Vent Restrictor Size Guidelines**," above.

Figure 15: Vent Restrictor

Power Vent Components

Locate the fireplace as per the instructions in this manual. Make the following modifications to add the components used with the Power Vent Kits. This kit can only be used in conjunction with "Direct-Vent" series electronic versions of Lennox™ Fireplaces. This installation must conform with local codes or, in the absence of local codes, with the Natural Fuel Gas Code, ANSI Z223.1/NFPA 54, or the Natural Gas and Propane Installation Code, CSA B149.1.

CAUTION: This Power Vent Kit cannot be used with Millivolt appliances. Use kit only with the Electronically controlled fireplaces listed for its use as shown in this document.

POWER VENT COMPONENTS

Item No.	Description	Qty.
1	Vacuum Hose	1
2	Termination Assembly	1
3	SV Termination Adaptor (SV4.5RCH)	1
4	Strain Relief - 3/8"	2
5	Firestop Assembly (Horizontal)	1
6	Hose Clamp - 11/32"	2
7	Snap Bushing	1
8	Ring Terminal - #10	2
9	Insulated 1/4" Male Terminal	4

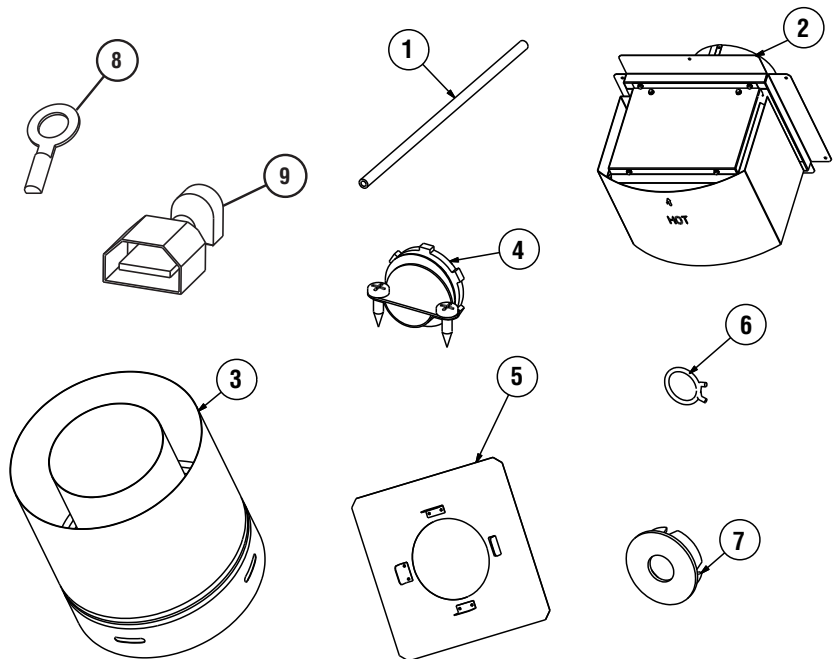

Figure 16: Power Vent Kit Components

VENT SECTION LENGTHS

Determine the number of straight vent sections required. 4-1/2" (114 mm), 10-1/2" (267 mm), 22-1/2" (572 mm), 34-1/2" (876 mm) and 46-1/2" (1181 mm) net section lengths are available. Refer to the Vent Section Length Chart.

Vertical (Offset) Installation

Analyze the vent routing and determine the quantities of vent sections and number of elbows required. Refer to **Figures 21 and 22 on Page 17** showing vent run requirements to aid in selecting the type of vertical installation desired. Vent sections are available in net lengths of 4-1/2" (114 mm), 10-1/2" (267 mm), 22-1/2" (572 mm), 34-1/2" (876 mm) and 46-1/2" (1181 mm). Refer to the **Vent Section Length Chart** for an aid in selecting length combinations. Elbows are available in 90° and 45° configurations. Refer to **Figure 20 on Page 16** for the SV4.5 E45 and SV4.5 E90 elbow dimensional specifications.

Where required, a **telescopic vent section (SV4.5LA)** may be used to provide the installer with an option in installing in tight and confined spaces or where the vent run made up of fixed length pieces develops a joint in a undesirable location, or will not build up to the required length. The SV4.5LA Telescopic Vent Section has an effective length of from 1-1/2" (38 mm) to 6-3/4" (171 mm). The SV4.5LA is fitted with a dimpled end (identical to a normal vent section component) and a plain end with 3 pilot holes. Slip the dimpled end over the locking channel end of a standard SV4.5 vent component the required distance and secure with three screws.

Maintain a minimum 1" (25 mm) clearance to combustible materials for all vertical elements. Clearances for all horizontal elements are 3" (76 mm) on top, 1" (25 mm) on sides and 1" (25 mm) on the bottom.

Effective Vent Length	
Model	Effective Length
SV4.5L6	4-1/2"
SV4.5L12	10-1/2"
SV4.5L24	22-1/2"
SV4.5L36	34-1/2"
SV4.5L48	46-1/2"

Table 7

VENT SECTION LENGTH CHART							TOTAL QTY
Nominal Section Length (inches)	6	12	24	36	48	TOTAL	
Net Section Length (inches)	4-1/2	10-1/2	22-1/2	34-1/2	46-1/2		
Height of Vent	Number of Vent Sections					TOTAL	
inches ft							
4.5	0.375	1	0	0	0	0	1
9	0.75	2	0	0	0	0	2
10.5	0.875	0	1	0	0	0	1
15	1.25	1	1	0	0	0	2
22.5	1.875	0	0	1	0	0	1
31.5	2.625	0	3	0	0	0	3
34.5	2.875	0	0	0	1	0	1
37.5	3.125	1	1	1	0	0	3
43.5	3.625	0	2	1	0	0	3
45	3.75	0	0	2	0	0	2
46.5	3.875	0	0	0	0	1	1
51	4.25	1	0	0	0	1	2
55.5	4.625	0	1	2	0	0	3
57	4.75	0	0	1	1	0	2
67.5	5.625	0	0	3	0	0	3
69	5.75	0	0	0	2	0	2
73.5	6.125	1	0	0	2	0	3
79.5	6.625	0	1	0	2	0	3
81	6.75	0	0	0	1	1	2
91.5	7.625	0	0	2	0	1	3
93	7.75	0	0	0	0	2	2
97.5	8.125	1	0	0	0	2	3
103.5	8.625	0	0	0	3	0	3
108	9	1	0	0	3	0	4
117	9.75	1	0	5	0	0	6
118.5	9.875	1	1	0	3	0	5
126	10.5	0	0	1	3	0	4
130.5	10.875	1	0	1	3	0	5
135	11.25	0	0	6	0	0	6
139.5	11.625	0	0	0	0	3	3
142.5	11.875	1	0	0	4	0	5
144	12	1	0	0	0	3	4
154.5	12.875	1	1	0	0	3	5
160.5	13.375	0	2	0	0	3	5
172.5	14.375	0	0	0	5	0	5
177	14.75	1	0	0	5	0	6
186	15.5	0	0	0	0	4	4
196.5	16.375	0	1	0	0	4	5
207	17.25	0	0	0	6	0	6
211.5	17.625	1	0	0	6	0	7
217.5	18.125	0	1	0	6	0	7
229.5	19.125	0	0	1	6	0	7
232.5	19.375	0	0	0	0	5	5
241.5	20.125	0	0	0	7	0	7
246	20.5	1	0	0	7	0	8
252	21	0	1	0	7	0	8

VENT SECTION LENGTH CHART							TOTAL QTY
Nominal Section Length (inches)	6	12	24	36	48	TOTAL	
Net Section Length (inches)	4-1/2	10-1/2	22-1/2	34-1/2	46-1/2		
Height of Vent	Number of Vent Sections					TOTAL	
inches ft							
276	23	0	0	0	8	0	8
279	23.25	0	0	0	0	6	6
280.5	23.375	1	0	0	8	0	9
289.5	24.125	0	1	0	0	6	7
301.5	25.125	0	0	1	0	6	7
310.5	25.875	0	0	0	9	0	9
325.5	27.125	0	0	0	0	7	7
330	27.5	1	0	0	0	7	8
345	28.75	0	0	0	10	0	10
349.5	29.125	1	0	0	10	0	11
372	31	0	0	0	0	8	8
379.5	31.625	0	0	0	11	0	11
418.5	34.875	0	0	0	0	9	9
465	38.75	0	0	0	0	10	10
475.5	39.625	0	1	0	0	10	11
480	40	1	1	0	0	10	11
492	41	1	0	1	0	10	12
499.5	41.625	0	0	0	1	10	11
504	42	1	0	0	1	10	12
511.5	42.625	0	0	0	0	11	11
520.5	43.375	0	2	0	1	11	14
531	44.25	0	2	2	0	11	15
538.5	44.875	1	0	0	2	11	14
549	45.75	1	0	2	1	11	15
558	46.5	0	0	0	0	12	12
562.5	46.875	1	0	0	0	12	13
568.5	47.375	0	1	0	0	12	13
573	47.75	1	1	0	0	12	14
580.5	48.375	0	0	1	0	12	13
589.5	49.125	0	1	2	2	10	15
595.5	49.625	1	1	1	0	12	15
604.5	50.375	0	0	0	0	13	13
615	51.25	0	1	0	0	13	14
625.5	52.125	0	2	0	0	13	15
631.5	52.625	1	0	1	0	13	15
637.5	53.125	0	1	1	0	13	15
651	54.25	0	0	0	0	14	14
655.5	54.625	1	0	0	0	14	15
672	56	0	2	0	0	14	16
678	56.5	1	0	1	0	14	16
688.5	57.375	1	1	1	0	14	17
697.5	58.125	0	0	0	0	15	15
702	58.5	1	0	0	0	15	16
712.5	59.375	1	1	0	0	15	17
720	60	0	0	1	0	15	16

Note: Convert inches into metric equivalent measurement, as follows:

- Millimeters (mm) = Inches x 25.4
- Centimeters (cm) = Inches x 2.54
- Meters (M) = Inches x .0254

A. Frame ceiling opening. Use a plumb line from the ceiling above the appliance to locate center of the vertical run. Cut and/or frame an opening, 10-1/2" x 10-1/2" (267 mm x 267 mm) inside dimensions, about this center mark (*Figure 17*).

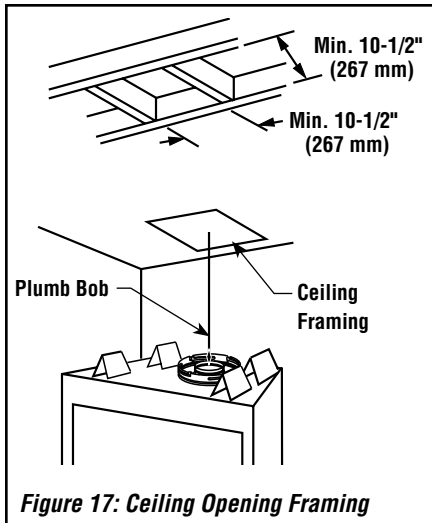

Figure 17: Ceiling Opening Framing

B. Attach adaptor (with probe) to appliance collar. Secure Vent™ SV4.5 direct-vent system components are unitized concentric pipe components featuring positive twist lock connections (*see Figure 18*).

All of the appliances covered in this document are fitted with collars having locking inclined channels. The dimpled end of the adaptor fits over the appliance collar to create the positive twist lock connection.

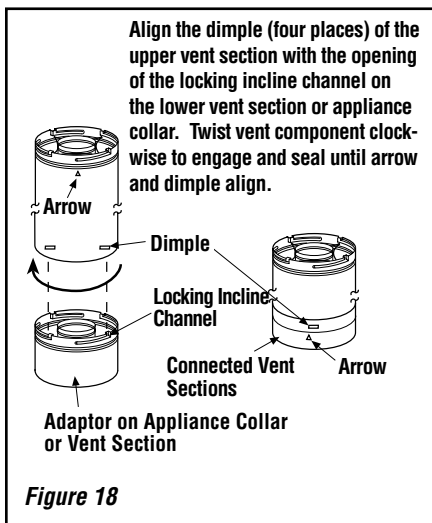

Figure 18

To attach a vent component to the adaptor on appliance collar, align the dimpled end over the adaptor collar, adjusting the radial alignment until the four locking dimples are aligned with the inlet of the four inclined channels on the collar (*refer to Figure 18*). Push the vent component against the collar until it fully engages, then twist the component clockwise, running the dimples down and along the incline channels until they seat at the end of the channels.

The unitized design of the **Secure Vent** components will engage and seal both the inner and outer pipe without the need for sealant or screws. If desired a #6 x 1/2" screw may be used at the joint, but it is not required as the pipe will securely lock when twisted.

C. Attach vent components to each other. Other vent sections may be added to the previously installed section in accordance with the requirements shown in *Figures 21 and 22 on Page 17*.

To add another vent component to a length of vent run, align the dimpled end over the inclined channel end of the previously installed section, adjusting the radial alignment until the four locking dimples are aligned with the inlets of the four incline channels of the previous section.

Push the vent component against the previous section until it fully engages, then twist the component clockwise running the dimples down and along the incline channels until they seat at the end of the channels. **This seating position is indicated by the alignment of the arrow and dimple as shown in Figure 18.**

D. Install firestop/spacer at ceiling. When using Secure Vent, use SV4.5VF firestop/spacer at ceiling joists. If there is living space above the ceiling level, the firestop/spacer must be installed on the bottom side of the ceiling. If attic space is above the ceiling, the firestop/spacer must be installed on the top side of the joist. Route the vent sections through the framed opening and secure the firestop/spacer with 8d nails or other appropriate fasteners at each corner. **Remember to maintain 1" (25 mm) clearance to combustibles, framing members, and attic or ceiling insulation when running vertical chimney sections.** Attic insulation shield (H3907) may be used to obtain the required clearances indicated here. See installation accessories on *Page 32*. The gap between the vent pipe and a vertical firestop can be sealed with non-combustible caulking.

E. Support the vertical vent run sections.

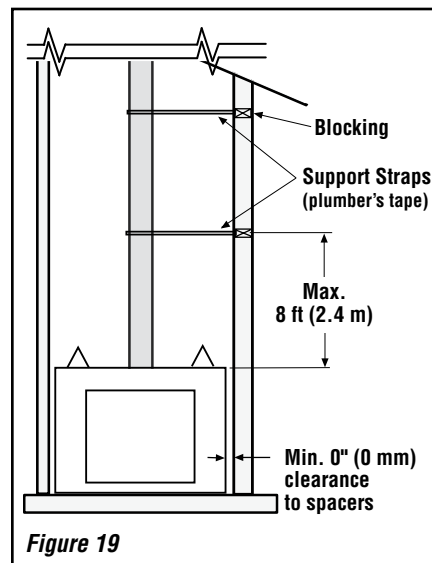

Figure 19

NOTE: DIAGRAMS & ILLUSTRATIONS ARE NOT TO SCALE.

Note: Proper venting support is very important. The weight of the vent must not be supported by the fireplace in any degree.

Support the vertical portion of the venting system every 8 feet (2.4 m) above the fireplace vent outlet. One method of support is by utilizing field provided support straps (conventional plumber's tape). Secure the plumber's tape to the framing members with nails or screws. Strap the tape around the vent, securing the ends of the tape to the framing. If desired, sheet metal screws #6 x 1/2" length may be used to secure the support straps to the vent pipe (*see Figure 19*).

F. Change vent direction to horizontal/inclined run. At transition from or to a horizontal/inclined run, install the SV4.5 E45 and SV4.5 E90 elbows in the same manner as the straight vent sections. The elbows feature a twist section to allow them to be routed about the center axis of their initial collar section to align with the required direction of the next vent run element. **Twist elbow sections in a clockwise direction only so as to avoid the possibility of unlocking any of the previously connected vent sections** (*see Figures 18 and 20*).

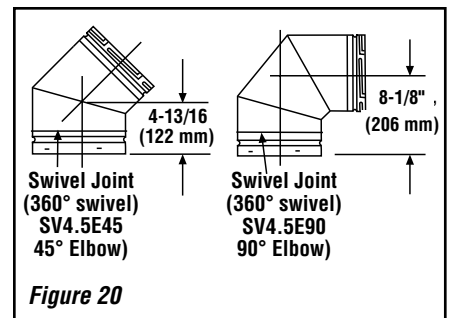

Figure 20

G. Continue installation of horizontal/inclined sections. Continue with the installation of the straight vent sections in horizontal/inclined run as described in **Step C**. Install support straps every 3' (914 mm) along horizontal/inclined vent runs using conventional plumber's tape (*see Page 17, Figure 21*).

NOTICE: It is important to install horizontal runs on a steady, (i.e., no "dips"), slightly positive incline of approximately 1/4 inch rise-per-foot (20 millimeters rise-per-meter) horizontal, in a direction away from the fireplace. (Slightly smaller rise-per-foot run ratios are acceptable.) Use a carpenter's level to measure from a constant surface, and adjust support straps as necessary.

It is important to maintain the required clearances to combustibles: 1" (25 mm) at all sides for all vertical runs; and 3" (76 mm) at the top, 1" (25 mm) at sides, and 1" (25 mm) at the bottom for all horizontal/inclined runs.

VENT FIGURES

Note:

- Secure Vent™ components (rigid vent pipe and terminal) are shown in the figures.
- Two 45 degree elbows may be used in place of one 90 degree elbow.
- SV4.5VF (Secure Vent) firestop/spacer must be used anytime vent pipe passes through a combustible floor or ceiling. SV4.5HF (Secure Vent) firestop/spacer must be used anytime vent pipe passes through a combustible wall.

⚠ NOTICE: It is important to install horizontal runs on a steady, (i.e., no “dips”), slightly positive incline of approximately 1/4 inch rise-per-foot (20 millimeters rise-per-meter) horizontal, in a direction away from the fireplace. (Slightly smaller rise-per-foot run ratios are acceptable.) Use a carpenter’s level to measure from a constant surface, and adjust support straps as necessary.

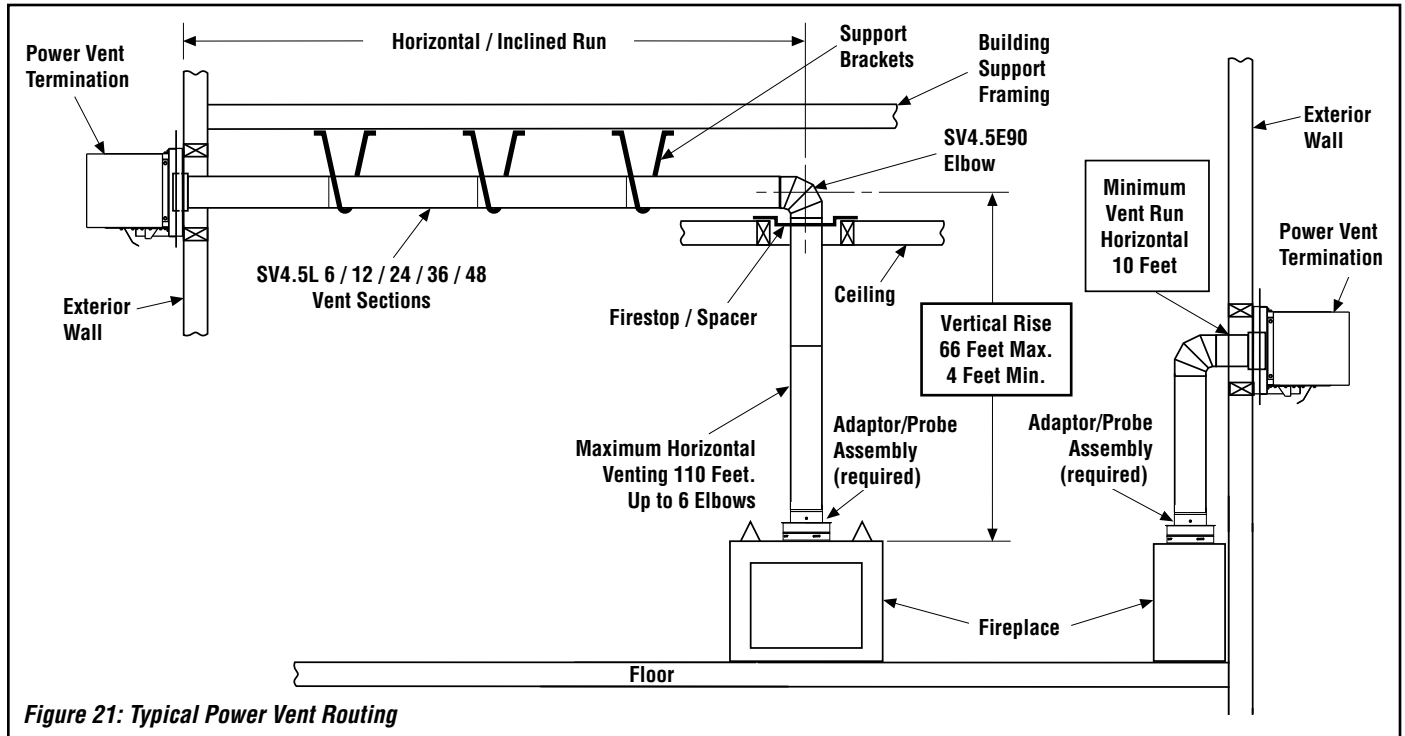

Figure 21: Typical Power Vent Routing

POWER VENT VENTING CHART		
Maximum Number Of Elbows	—	6
Maximum Feet Of Run	A + B	110 feet
Minimum Horizontal Run	B	10 feet
Minimum Vertical Run	A	Adaptor plus 4 ft (min.) Vertical Vent and 90° Elbow
Maximum Vertical Rise	A	66 ft

MINIMUM CLEARANCES TO COMBUSTIBLES	
Vertical Vent Pipe	1.0 in. (25.4 mm)
Horizontal Vent Pipe	Top - 3.0 in. (76.2 mm) Sides - 1.0 in. (25.4 mm) Bottom - 1.0 in. (25.4 mm)

Figure 22

HORIZONTAL (OUTSIDE WALL) TERMINATION SYSTEM

See **Figures 21 and 22 on Page 17** illustrating the various horizontal venting configurations that are possible for use with these appliances. The table in **Figure 22 on Page 17** shows each system's minimum and maximum vertical and horizontal length values that can be used to design and install the vent components in a variety of applications.

The horizontal vent system terminates through an outside wall. Building Codes limit or prohibit terminating in specific areas. Refer to **Figure 3 on Page 6** for location guidelines.

Secure Vent™ SV4.5 direct-vent system components are unitized concentric pipe components featuring positive twist lock connection, (refer to **Figure 18 on Page 16**). All of the appliances covered in this document are fitted with collars having locking inclined channels. The dimpled end of the vent components fit over the appliance collar to create the positive twist lock connection.

A. Plan the vent run.

Analyze the vent routing and determine the types and quantities of sections required 4-1/2" (114 mm), 10-1/2" (267 mm), 22-1/2" (572 mm), 34-1/2" (876 mm) and 46-1/2" (1181 mm) net section lengths are available. Make allowances for elbows as indicated in **Figure 20 on Page 16**.

Maintain a minimum 1" (25 mm) clearance to combustibles on the vertical sections. Clearances for the horizontal runs are; 3" (76 mm) on top, 1" (25 mm) on sides, and 1" (25 mm) at the bottom.

B. Frame exterior wall opening.

Locate the center of the vent outlet on the exterior wall according to the dimensions shown in **Figure 11 on Page 11**.

Cut and/or frame an opening, 10-1/2" x 12-1/8" (267 mm x 308 mm) inside dimensions, with 7-1/2" above center and 5-5/8" below center.

C. Frame ceiling opening.

If the vertical route is to penetrate a ceiling, use plumb line to locate the center above the appliance. Cut and/or frame an opening, 10-1/2" x 10-1/2" (267 mm x 267 mm) inside dimensions, about this center (refer to **Figure 17 on Page 16**).

D. Attach vent components to appliance.

To attach a vent component to the appliance collar, align the dimpled end over the collar, adjusting the radial alignment until the four locking dimples are aligned with the inlets of the four incline channels on the collar (refer to **Figure 18 on Page 16**).

Push the vent component against the collar until it fully engages, then twist the component clockwise, running the dimples down and along the incline channels until they seat at the end of the channels. The unitized design of the **Secure Vent** components will engage and seal both the inner and outer pipe elements with the same procedure. Sealant and securing screws are not required.

E. Attach vent components to each other.

Other vent sections may be added to the previously installed section in accordance with the requirements of the vent tables. To add another vent component to a length of vent run, align the dimpled end of the component over the inclined channel end of the previously installed section, adjusting the radial alignment until the four locking dimples are aligned with the inlets of the four incline channels of the previous section. Push the vent component against the previous section until it fully engages, then twist the component clockwise running the dimples down and along the incline channels until they seat at the end of the channels. **This seating position is indicated by the alignment of the arrow and dimple as shown in Figure 18 on Page 16.**

F. Install firestop/spacer at ceiling.

When using **Secure Vent**, use SV4.5VF firestop/spacer at ceiling joists. If there is living space above the ceiling level, the firestop/spacer must be installed on the bottom side of the ceiling. If attic space is above the ceiling, the firestop/spacer must be installed on the top side of the joist. Route the vent sections through the framed opening and secure the firestop/spacer with 8d nails or other appropriate fasteners at each corner.

Remember to maintain 1" (25 mm) clearance to combustibles, framing members, and attic or ceiling insulation when running vertical chimney sections.

G. Support the vertical run sections.

On the vertical run, support the venting system every 8 feet (2.4m) above the fireplace vent outlet with field provided support straps (Plumber's tape). Attach the straps to the vent pipe and secure to the framing members with nails or screws. See **Figure 19 on Page 16**.

H. Change vent direction.

At transition from or to a horizontal/inclined run, install the SV4.5E45 and SV4.5E90 elbows in the same manner as the straight vent sections. The elbows feature a twist section to allow them to be routed about the center axis of their initial collar section to align with the required direction of the next vent run element. **Twist elbow sections in a clockwise direction only so as to avoid the possibility of unlocking any of the previously connected vent sections (see Figures 18 and 20 on Page 16).**

I. Continue installation of horizontal/inclined sections.

Continue with the installation of the straight vent sections in horizontal/inclined run as described in **Step E**. Install support straps every 3 feet (914 mm) along horizontal/inclined vent runs using conventional plumber's tape.

See **Figure 21 on Page 17**.

⚠ NOTICE: It is important to install horizontal runs on a steady, (i.e., no "dips"), slightly positive incline of approximately 1/4 inch rise-per-foot (20 millimeters rise-per-meter) horizontal, in a direction away from the fireplace. (Slightly smaller rise-per-foot run ratios are acceptable.) Use a carpenter's level to measure from a constant surface, and adjust support straps as necessary.

Installing Power Vent Termination

J. Assemble vent run to exterior wall.

If not previously measured, locate the center of the vent on the exterior wall. Prepare an opening as described in this manual. Assemble the vent system to a point where the terminus of the last section is within 8 inches of the outside wall surface where the power vent is to be mounted (refer to **Figure 24 on Page 19**).

If the terminus of the last section is not within this distance, use the **telescopic vent section SV4.5LA**, as the last vent section. For wall thicknesses greater than that shown in **Figure 24 on Page 19**, refer to **Table 8 (Page 19)** for the additional venting components needed (in addition to the termination and adaptor) for a particular range of wall thicknesses.

K. Attach termination adaptor.

Attach the adaptor (SV4.5RCH, provided with the power vent kit) to the vent section telescopic vent section, or elbow, as shown in **Figures 23 and 24 on Page 19** in the same manner as any SV4.5 vent component.

L. Install Firestop/Spacer at exterior wall.

Install SV4.5HF Firestop/Spacer, provided with the power vent kit, over the opening at the exterior side of the framing, long side up, with the 3 inch spacer clearance at the top as shown in **Figure 23**, and nail into place.

(The Firestop/Spacer may also be installed over the opening at the interior side of the framing).

M. Install the Power Vent termination.

For the last step, from outside the exterior wall, slide the collars of the termination onto the adaptor (the outer inside the outer and the inner outside the inner) until the termination seats against the exterior wall surface to which it will be attached. Orient the housing of the termination with the arrow pointed upwards. Secure the termination to the exterior wall. **The termination must not be recessed into the exterior wall or siding** by more than the 1-1/4" (32 mm) as shown in **Figure 24**.

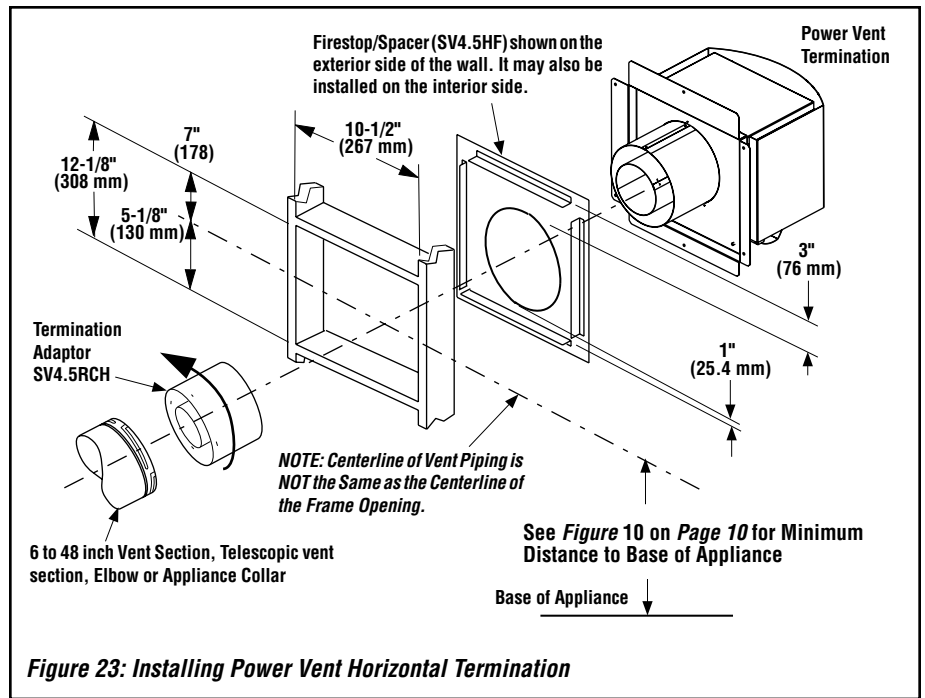

Figure 23: Installing Power Vent Horizontal Termination

The Power Vent termination has been designed to perform in a wide range of weather conditions. Our terminations meet or exceed industry standards.

When selecting the location of your termination, do not place the termination where water from eaves and adjoining roof lines may create a heavy flow of cascading water onto the terminations. If the termination must be placed where the possibility of cascading water exists, it is the responsibility of the builder to direct the water away from the termination cap by using gutters or other means.

Take care to carefully follow the Installation Instructions for the termination, including the use of silicone caulking where required.

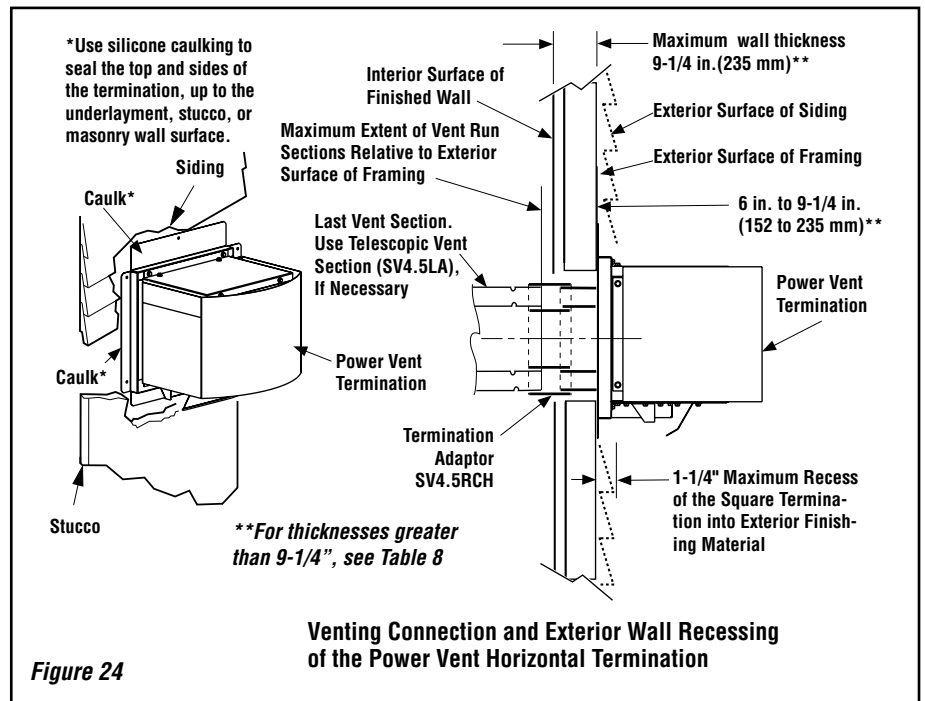

Figure 24

See Table 8 as an aid in venting component selection for a particular range of exterior wall thicknesses.

IMPORTANT: The vent termination is hot while in operation and for a period of time following the use of the fireplace. Young children should be carefully supervised when they are in the same area as a hot termination.

Venting Components Required for Various Exterior Wall Thicknesses, When Using The Power Vent Termination	
Vent Components Required	Exterior Wall Thickness - inches (mm)
Termination Kit Only	6 to 9-1/4 (152 to 235)
Termination Kit and 6 In. Vent Section (SV4.5L6)	10-3/4 to 14 (273 to 356)
Termination Kit and 12 in. Vent Section (SV4.5L12)	16-3/4 to 20 (426 to 508)
Termination Kit and Telescopic Section (SV4.5L12)	11-3/4 to 20 (299 to 508)

Table 8

Step 4. FIELD WIRING

CAUTION: Label all wires prior to disconnection when servicing controls. Wiring errors can cause improper and dangerous operation.

ATTENTION: Au moment de l'entretien des commandes, étiquetez tous les fils avant de les débrancher. Des erreurs de câblage peu-vent entraîner un fonctionnement inadéquat et dangereux.

Verify proper operation after servicing.

S'assurer que l'appareil fonctionne adéquatement une fois l'entretien terminé.

CAUTION: Ground supply lead must be connected to the wire attached to the green ground screw located on the outlet box. See *Figures 32 and 33 on Page 22*. Failure to do so will result in a potential safety hazard. The appliance must be electrically grounded in accordance with local codes or, in the absence of local codes, the National Electrical Code, ANSI/NFPA 70-latest edition (In Canada, the current CSA C22-1 Canadian Electrical Code).

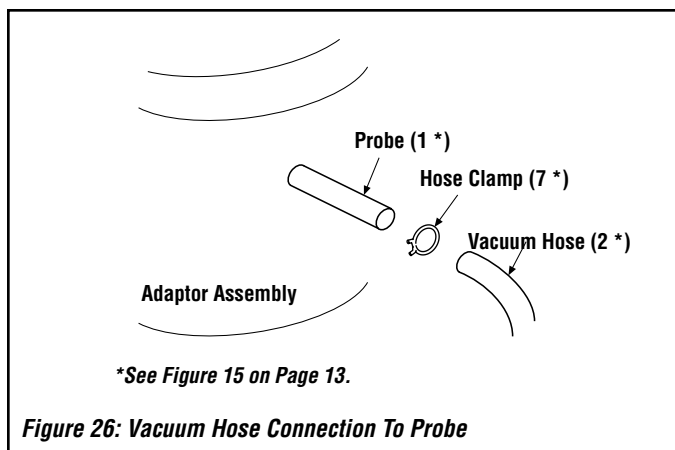
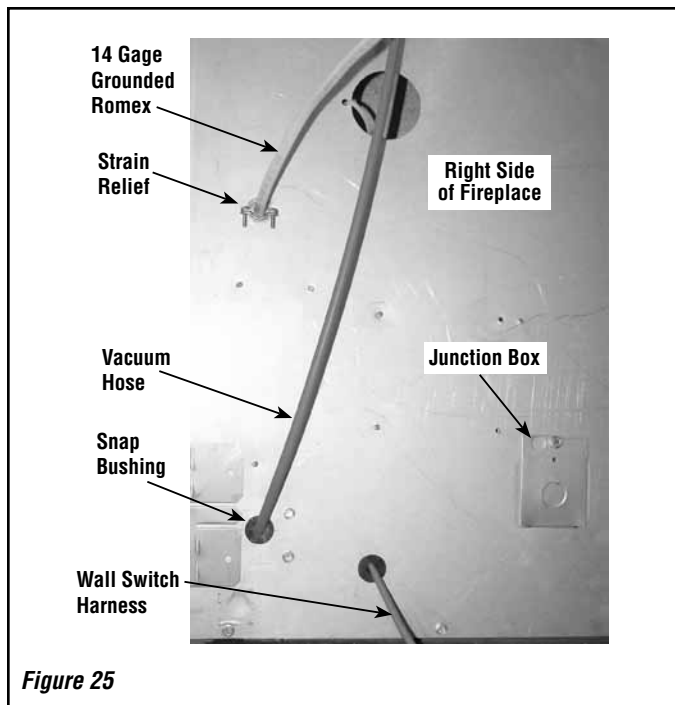

Route Wiring

NOTE: Electrical wiring must be performed by a qualified electrician.

- Install the strain relief in the hole provided on the right side of fireplace for the electrical wiring (*refer to Figure 25*).

Standard Instruction (For use when access to the termination is difficult because of height or other reasons).

- Locate a locally procured electrical junction box within reach of the termination wiring pigtail (*refer to Figure 28 on Page 21*) and route the pigtail to the junction box as the termination is installed.
- Route 14 gauge AWG grounded Romex wiring (not provided) from the fireplace to the just installed junction box close to the termination. Ensure the wiring is safety plated to prevent damage by framing nails and finish drywall screws. Route the wire into the lower control compartment and cut to length before installing the terminals. Install provided wiring hardware on the ends of the Romex wire.
- Refer to *Figure 29 on Page 21* and install the electrical hardware on the ends of the Romex wiring. Male terminals on the Black and White wires, and ring terminals on the ground wire.
- Using standard electrical practices and the terminals provided, connect the three wires of the Romex cable to the termination pigtail within the Electrical junction box. Ensure ground.
- The fireplace end of the Romex will be addressed in **Connecting The Power Vent To The Fireplace Control System**.

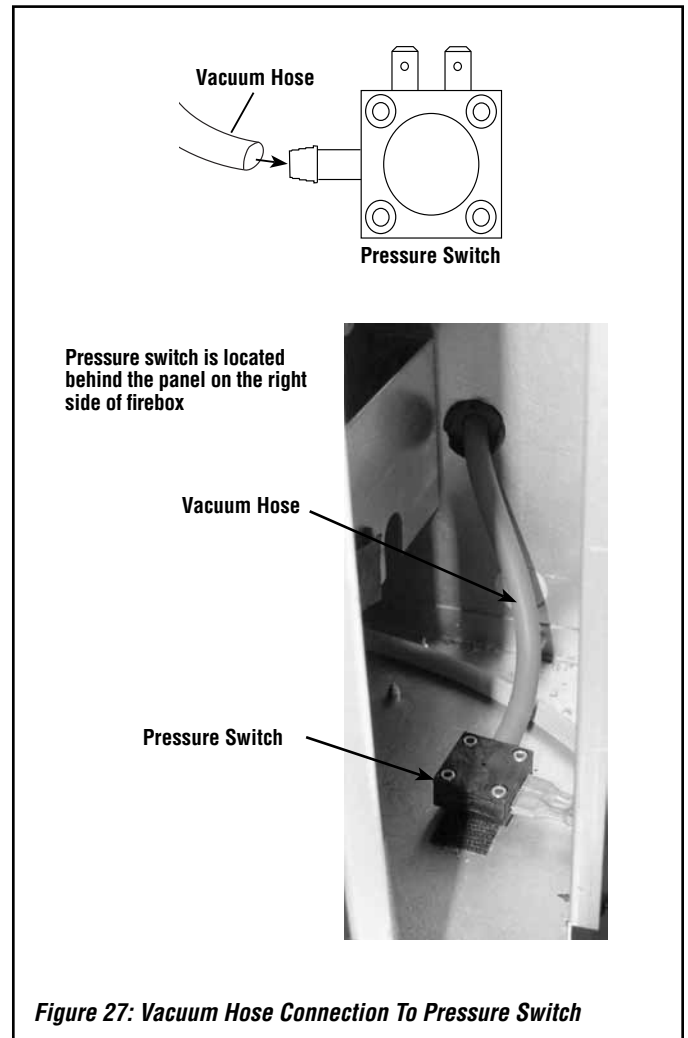

Wiring: Fireplace (See Figures 32 and 33 on Page 22)

Note: These electronic appliances must be connected to the main power supply. The gas valve is set in place and pre-wired at the factory.

1. Route a 3-wire 120Vac 60Hz 1ph power supply to the appliance junction box.
2. Remove the electrical inlet cover plate from the side of the unit by removing the plate's securing screws (see Figure 12 on Page 12).
3. Remove the cover plate's knockout and then feed the power supply wire through the knockout opening and into the unit junction box.
4. Connect the black power supply wire to the **power outlet's** red pigtail lead and the white power supply wire to the **common** terminal of the outlet as shown in Figures 31 and 32.
5. Connect the ground supply wire to the pigtail lead attached to outlet's green ground screw.
6. After the wiring is complete, replace the cover plate.

Wiring: Power Vent Termination

Alternate Instructions (For use when access to the termination is easy and a secondary electrical junction box installation is not desired).

- Remove the junction box cover from the termination by removing the attaching screw (refer to Figure 28).
- Loosen the strain relief on the termination shown in Figure 28. Pull the pigtail in and shorten it to fit within the junction box cover.
- Route 14 gauge AWG grounded Romex wiring (not provided) from fireplace to the J-Box at the termination. Ensure the wiring is safety plated to prevent damage by framing nails and finish drywall screws. Route the wire into the lower control compartment and cut to length before installing the terminals. Install provided wiring hardware on the fireplace end of the Romex wire.
- Refer to Figure 32 on Page 22 and install the electrical hardware on the fireplace end of the Romex wiring. Male terminals (#10) on the Black and White wires, and ring terminals (#9) on the ground wire. The termination end of the Romex will be connected to the termination with wire nuts (not provided).
- Refer to Figure 31 to connect the three wires of the Romex cable to the termination. Ensure the ground ring terminal is grounded beneath a structural screw as shown. Attach the junction box cover to the termination with the screw previously removed.
- The fireplace end of the Romex will be addressed in **Connecting The Power Vent To The Fireplace Control System**.

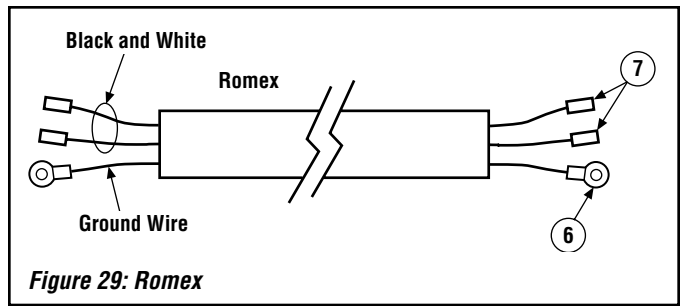

Figure 29: Romex

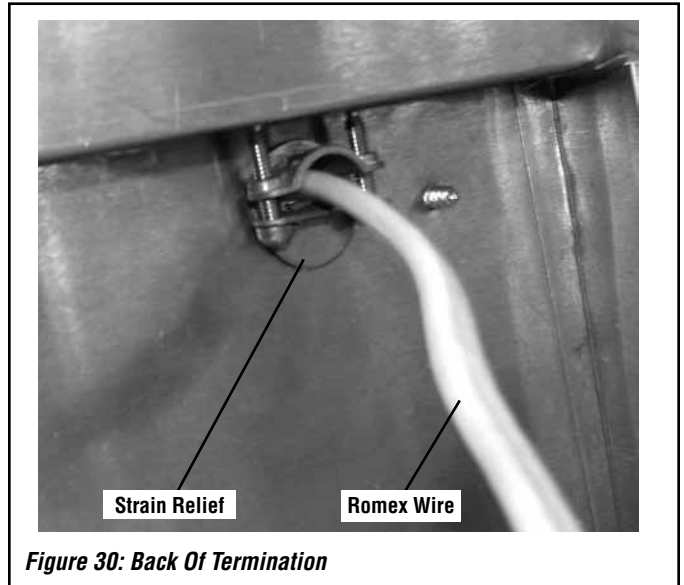

Figure 30: Back Of Termination

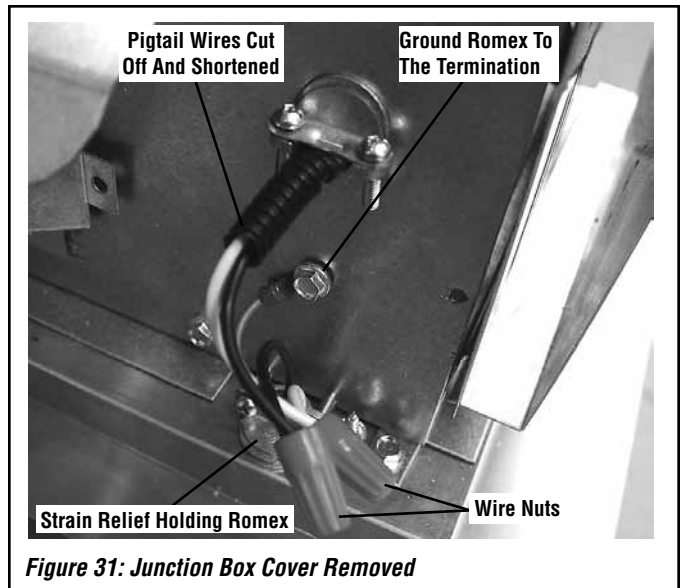

Figure 31: Junction Box Cover Removed

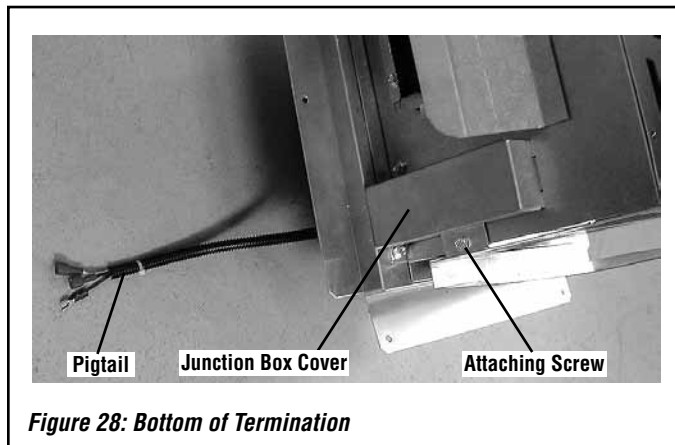

Figure 28: Bottom of Termination

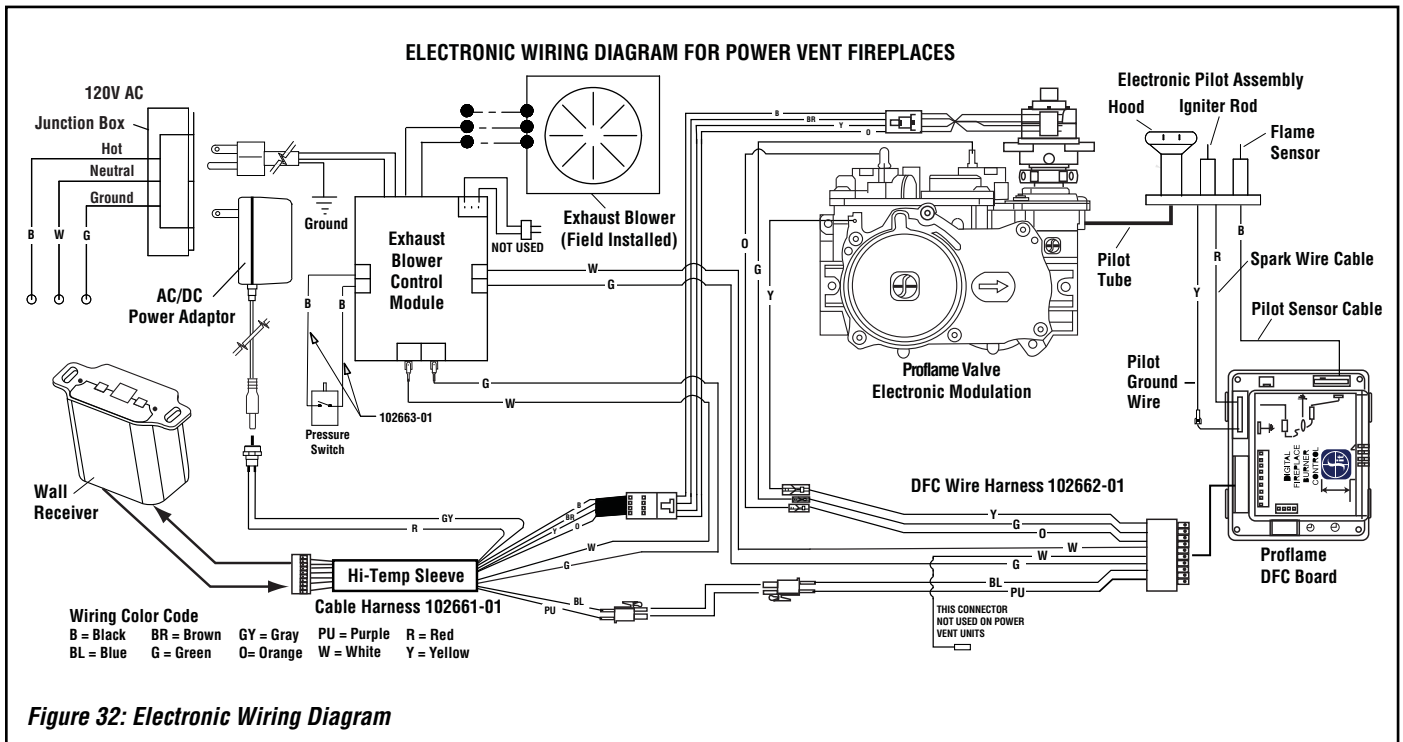

Figure 32: Electronic Wiring Diagram

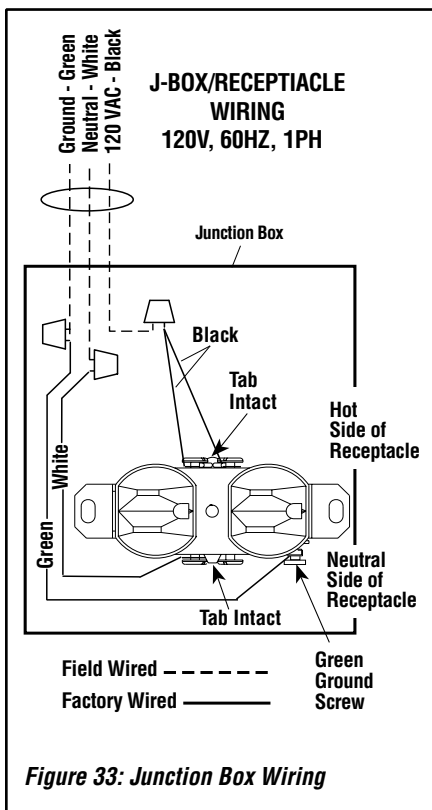

Figure 33: Junction Box Wiring

Step 5. REMOVE GLASS DOOR ASSEMBLY (ON CONTROL SIDE)

! WARNING

- Handle this glass with extreme care! Glass is susceptible to damage – Do not scratch or handle roughly while reinstalling the glass door frame.
- Do not attempt to substitute the materials used on this door, or replace cracked or broken glass with any materials other than those provided by the appliance manufacturer.
- The glass door of this appliance must only be replaced as a complete unit as provided by the manufacturer. Do not attempt to replace broken, cracked or chipped glass separately.

If not already done, remove the glass door assembly on the control side of the fireplace (see [Page 27](#)).

Step 6. CONNECT GAS LINE

All codes require a shut-off valve mounted in the supply line. The orientation of the shut-off valve should face the front. **Figure 35** illustrates two methods for connecting the gas supply. A Sediment Trap is recommended to prevent moisture and debris in gas line from damaging the valve.

The flex-line method is acceptable in the U.S.A. where local codes permit, however, Canadian requirements vary depending on locality. Installation must be in compliance with local codes. These appliances are equipped with a gas flex-line for use in connecting the unit to the gas line.

See **Figure 35** for flex-line description. The flex-line is rated for both natural and propane gas.

A manual shut off valve is also provided with the flex-line. The gas control valve is located on the right side of the unit.

When using solid gas line connector, access the valve by removing the front door assembly on the control side and the access plate (**refer to Figure 34**).

The electronic control valve has a 3/8" (10 mm) NPT thread gas supply inlet.

Secure all joints tightly using appropriate tools and sealing compounds (ensure propane resistant compounds are used in propane applications). It is recommended to seal around the gas line to prevent cold air leakage.

Bring the shutoff valve on the end of the flex-line over to the hard pipe and tighten with wrenches from above through the firebox opening.

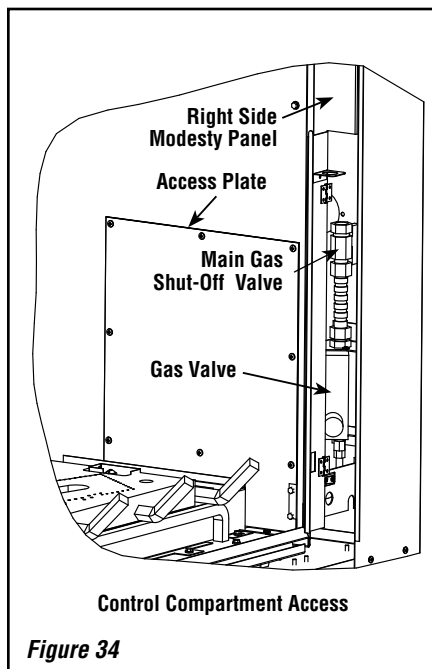

Figure 34

TEST ALL CONNECTIONS FOR GAS LEAKS (FACTORY AND FIELD):



Turn on gas supply and test for gas leaks using a gas leak test solution (also referred to as bubble leak solution). **Note:** Using a soapy water solution is an effective leak test solution but it is not recommended, because the soap residue that is left on the pipes/fittings can result in corrosion over time.

- A. Light the appliance (refer to the lighting instructions label in control compartment or in the Care and Operation Instructions manual).
- B. Brush all joints and connections with the gas leak test solution to check for leaks. If bubbles are formed, or gas odor is detected, turn the receiver or remote control to the "OFF" position. Either tighten or refasten the leaking connection, then retest as described above.
- C. When the gas lines are tested and leak free be sure to rinse off the leak testing solution.
- D. Reinstall the access plate, making certain the gasket has not been damaged.

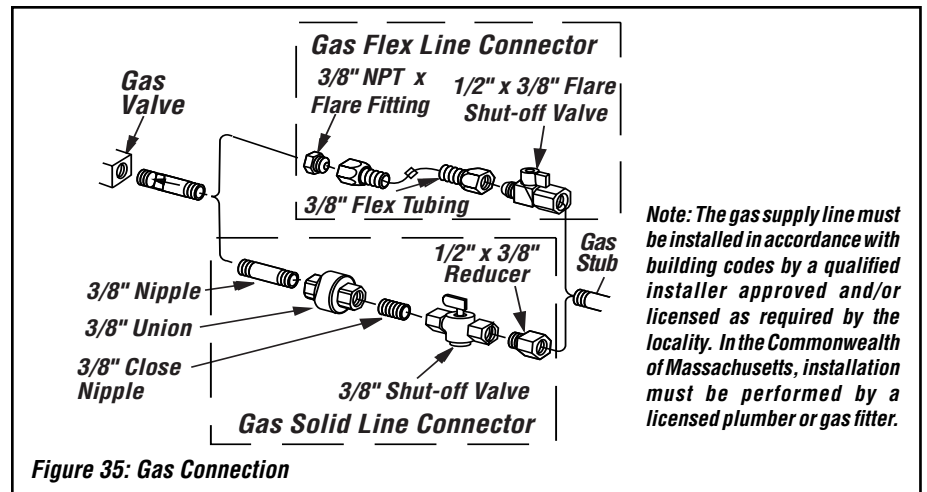

Figure 35: Gas Connection

Step 7. INSTALL FIREBOX LINER PANELS

Install the ceramic or porcelain liner panels per the instructions provided in the kit (ref. document P/N 506019-21).

NOTICE: Panel liners must be installed before operating fireplace.

Step 8. VERIFY APPLIANCE OPERATION

Turn on burner; then observe the individual tongues of flame on the burner. Make sure all ports are open and producing flame evenly across the burner. If any ports are blocked, or partially blocked, clean out the ports.

With gas line installed run initial system check-out before closing up the front of the unit. Follow the pilot lighting instructions provided.

Note: Lighting Instructions are also found on the literature tag tied to the bracket above the gas valve. To access the tag, reach into the right side opening.

When first lighting the appliance, it will take a few minutes for the line to purge itself of air. Once purging is complete, the pilot and burner will light and operate as indicated in the instruction manual. Subsequent lighting of the appliance will not require such purging. Inspect the pilot flame (remove logs, if necessary, handling carefully).

Appliance Checkout

To light the burner, refer to the lighting instructions in the Care and Operation Instructions manual or the lighting label located behind right panel. Ensure the igniter lights the pilot. The pilot flame should engulf the flame sensor as shown in **Figure 36**.

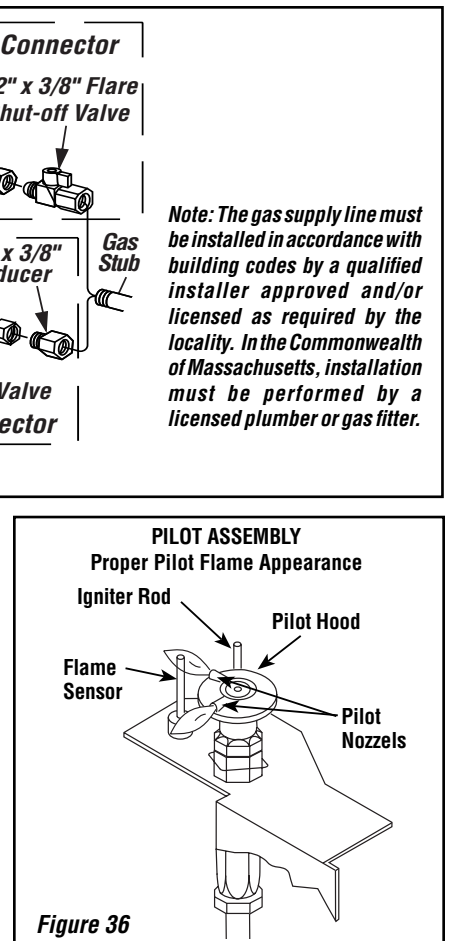

Figure 36

Step 9. INSTALL VOLCANIC STONE, GLOWING EMBERS, AND LOGS

9-1. Remove mesh pull screens, modesty panel, and glass door assembly from one side of fireplace. See **Page 27**.

9-2. Locate materials (log set, bag of glowing embers, and bags of volcanic stone).

Note: LOGS ARE FRAGILE! Handle with care to prevent breakage.

9-3. Install volcanic stone. Place some of the volcanic stone on the firebox floor around the grate (the entire bag of volcanic stone will NOT be used).

Note: Do NOT place volcanic stone on burner.

9-4. Prepare and install glowing embers.

Note: This appliance is provided with enough glowing ember material for several applications. Do NOT use the entire contents of a new bag at one time.

- a) Separate some of the glowing ember material into pieces **about the size and thickness of a dime** (see **Figure 37**). Keep the pieces fluffed up, not matted.

⚠ IMPORTANT! Ember pieces must be as SMALL and THIN as a dime.

- b) Distribute the dime-sized pieces over the surface of the burner, in the areas shown in **Figures 38 and 39**.

Note: To prevent flame impingement and soot, do not use more ember material than necessary.

- c) For best glowing effect, replace ember material annually.

Note: Use only catalog number H8312 Glowing Embers with this fireplace.

⚠ WARNING

- **DO NOT attempt to install the logs until the appliance installation has been completed, the gas line connected and tested for leaks, and the initial burner operation has been checked out.**
- **Logs get very hot and will remain hot up to one hour after gas supply is turned off. Handle only when logs are cool. Turn off all electricity to the appliance before you install volcanic stone, embers and logs.**
- **The size and position of the log set was engineered to give the appliance a safe, reliable and attractive flame pattern. Any attempt to use a different log set in the fireplace will void the warranty and will result in incomplete combustion, sooting, and poor flame quality.**
- **This appliance is not designed to burn wood. Any attempt to do so could cause irreparable damage to the appliance and prove hazardous to your safety.**
- **If logs are not installed according to the log installation instructions, flame impingement and improper combustion could occur and result in soot and/or excessive production of carbon monoxide (CO), a colorless, odorless, toxic gas.**

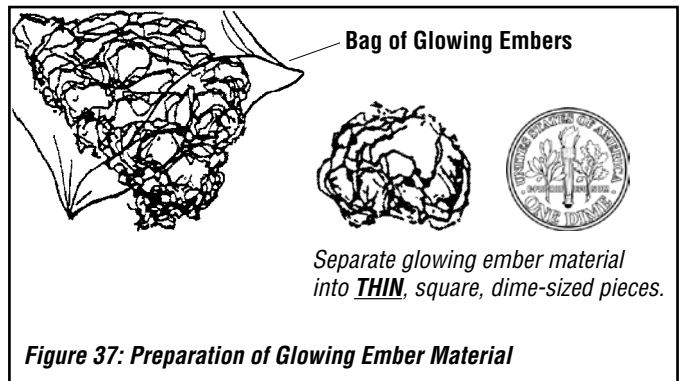

Figure 37: Preparation of Glowing Ember Material

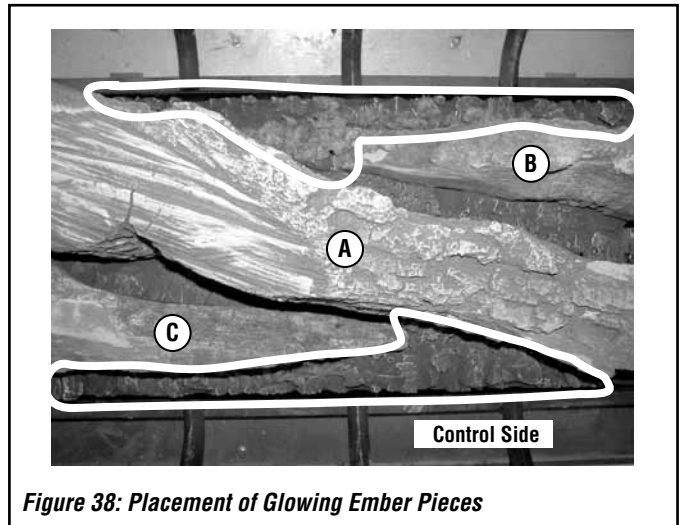

Figure 38: Placement of Glowing Ember Pieces

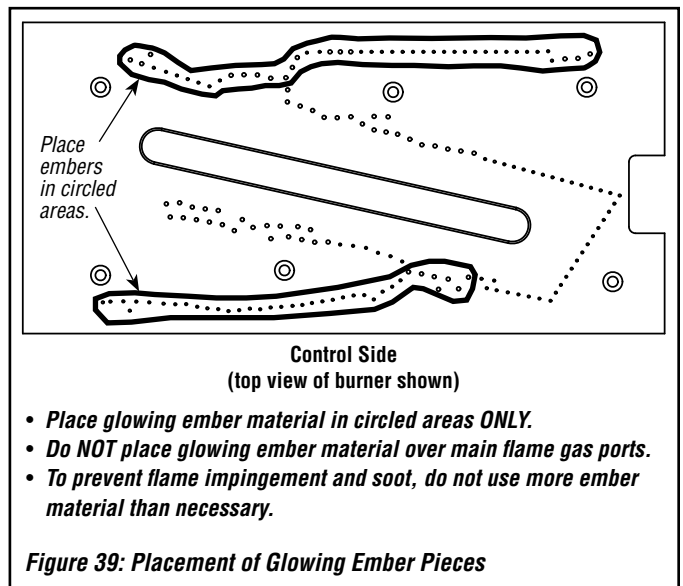

Figure 39: Placement of Glowing Ember Pieces

9-5. Install logs (reference *Figure 40* and *Table 9*).

Note: Logs are FRAGILE! Handle with care to prevent breakage.

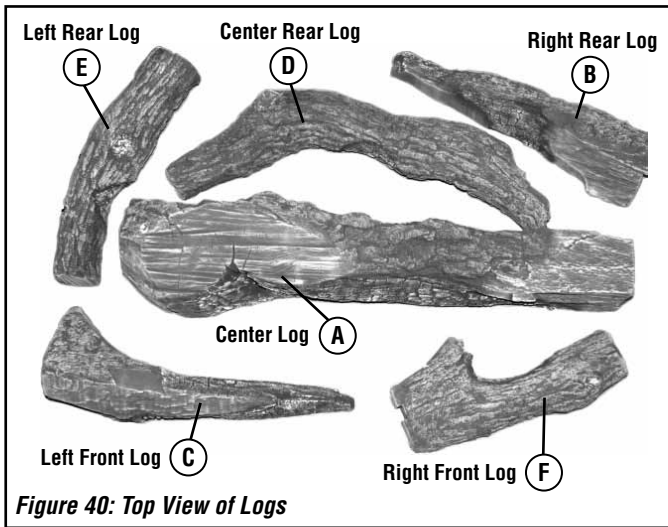

Figure 40: Top View of Logs

LOG SET			
Item*	Description	Item*	Description
A	Log, Center	D	Log, Top Right
B	Log, Right Rear	E	Log, Top Left
C	Log, Left Front	F	Log, Top Front

**Item letters correspond to photos.*

FIREBOX ACCESSORIES/PARTS		
Cat. No.	Model	Description
H8312	PGE	Bag of Glowing Embers
80L42	FDVS	Bag of Volcanic Stone

Table 9

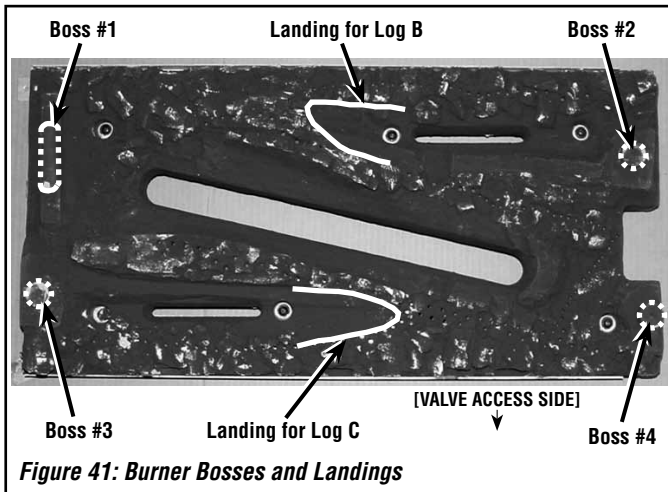

Figure 41: Burner Bosses and Landings

9-6. Place rectangular notches on underside of Center Log A (*Figure 42*) over **Boss #1** and **Boss #4** (*Figure 41*).

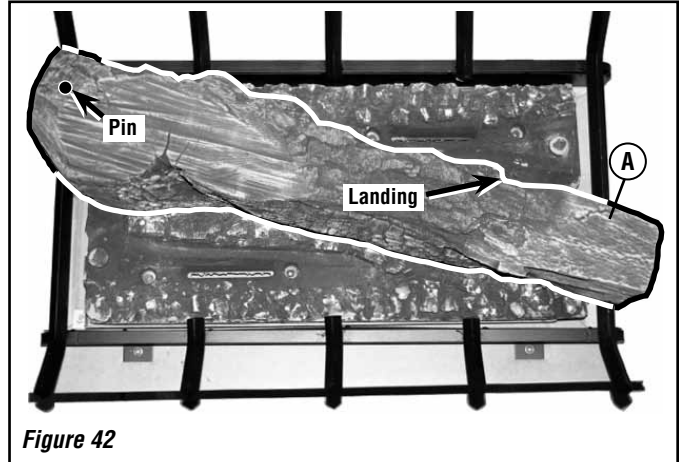

Figure 42

9-7. Place notch on underside of Right Rear Log B (*Figure 43*) over **Boss #2** (*Figure 41*).

Place opposite end of **Right Rear Log B** (*Figure 43*) on **Landing for Log B** (see *Figure 41*).

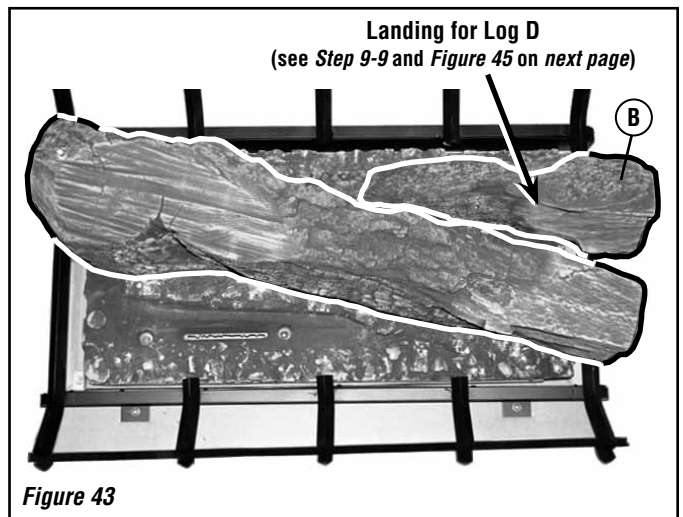

Figure 43

9-8. See Figures 41 and 44. Place notch on underside of Left Front Log C over **Boss #3**.

Place opposite end of **Left Front Log C** on **Landing for Log C** (see *Figure 41*).

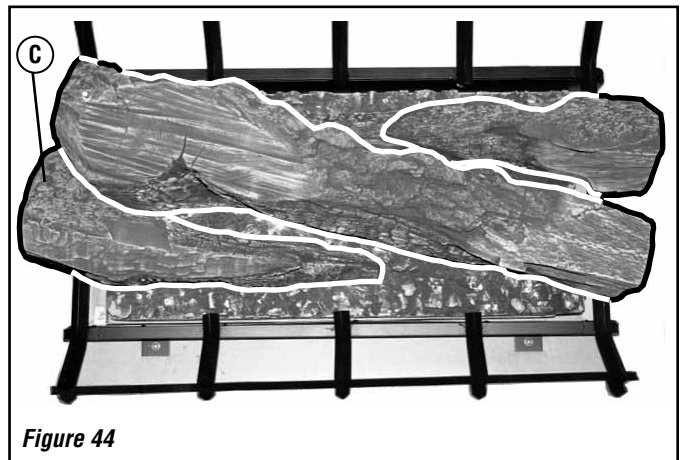
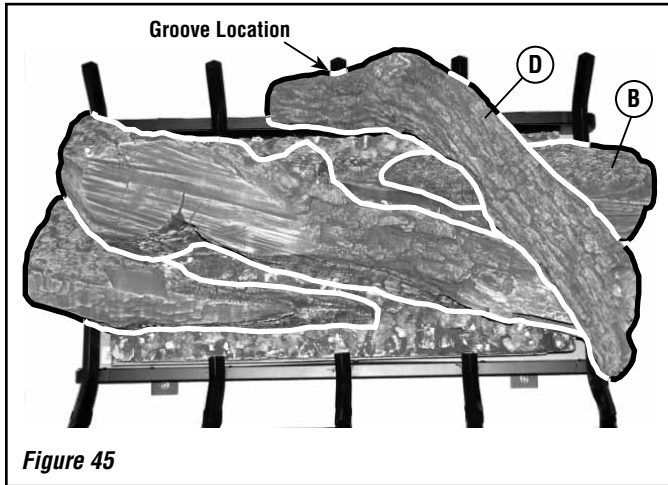

Figure 44

9-9. Place groove on underside of **Top Right Log D** over the grate as shown in **Figure 45**.

The middle section of **Log D** will rest on the landing on **Log B** (labeled as “**Landing for Log D**” in **Figure 43**).



9-10. See **Figure 46**. Place hole on underside of **Top Left Log E** over pin on **Center Log A**.

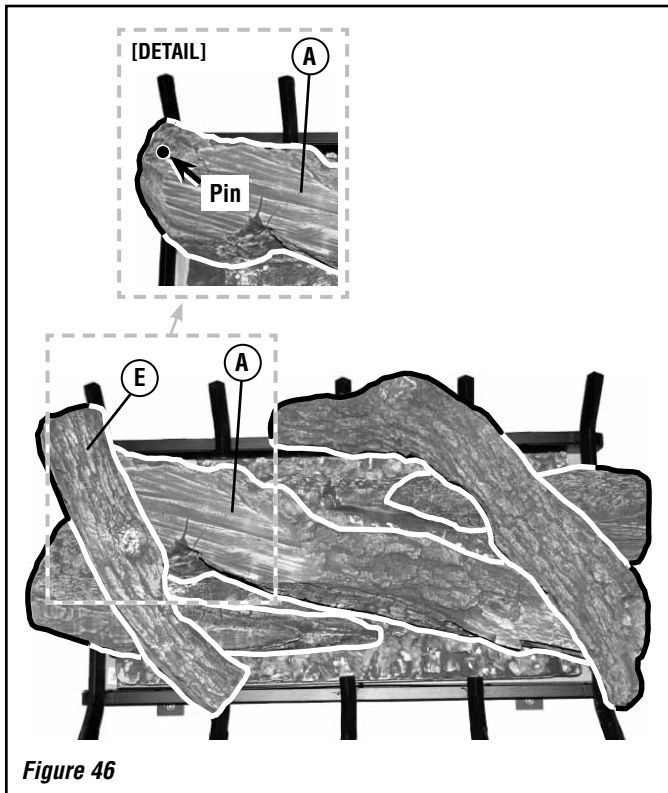

9-11. See **Figure 47**. Place groove on underside of **Top Front Log F** over the grate finger. Rest the other end of the log on the **Landing** on **Center Log A**.

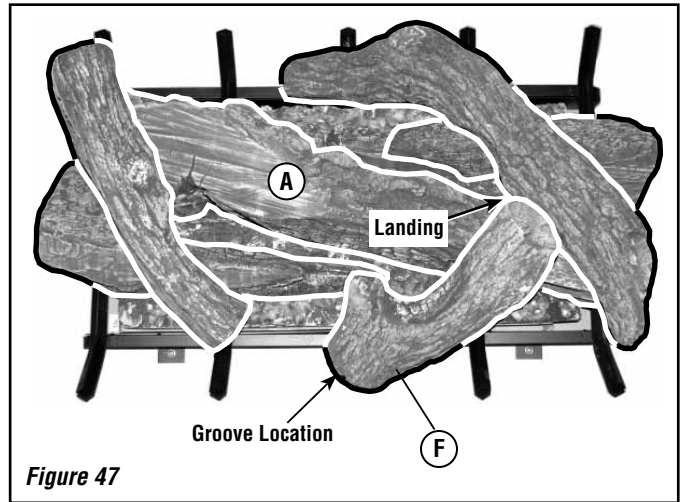

Step 10. INSTALL GLASS DOORS, MESH PULL SCREENS, AND MODESTY PANEL

⚠ WARNING

**HOT GLASS WILL CAUSE BURNS.
DO NOT TOUCH GLASS UNTIL COOLED.**

- Install only when fireplace is **OFF** and **COLD**.
- Fireplace surfaces get **EXTREMELY HOT!**
- The glass on the front of the fireplace reaches **EXTREMELY HIGH** temperatures and can cause severe burns if touched. Even after the gas is turned off, fireplace surfaces remain extremely hot.

⚠ CAUTION

**RISK OF PERSONAL INJURY
OR PROPERTY DAMAGE.**

- Do **NOT** abuse glass doors by striking or slamming shut
- **Never operate fireplace with glass door assemblies removed.**
These direct-vent appliances are designed to operate only when both glass door assemblies are installed. Generally, the glass door assemblies should not be removed, except when access to components within the firebox is required.
- **Securely tighten door latch screws when reinstalling glass door assemblies to prevent doors from falling out.**
- **Handle glass door assemblies with extreme care. Replace damaged glass door assemblies with approved replacement assemblies only.**
The door assemblies on this fireplace contain ceramic glass. Handle with care to prevent damage. If the door frame or glass on either assembly becomes damaged, replace the entire glass door assembly with a manufacturer-approved replacement assembly only. Do not attempt to substitute any materials used on door assemblies or replace cracked or broken glass with any other materials.
- **Only doors certified with the appliance shall be used.**
 - **Seules des portes certifiées pour cet appareil doivent être utilisées.**

Installing Glass Doors, Mesh Pull Screens, and Modesty Panel (see Figure 48)

Note: These instructions do NOT apply to the Outer Glass Door provided in the Outdoor Kit (for indoor/outdoor installations).

- 1) Install one of the glass doors, as follows:
 - a) Retrieve the glass door. Visually inspect the gasket on the back of the frame. Gasket surface must be clean, free of irregularities, and seated firmly.
 - b) Position the door in front of the firebox opening, with the top of the door held away from the fireplace (see **Figure 48**).
 - c) Lower the bottom of the door assembly onto the bottom door track, engaging and centering it in the base channel, and then gently swing the door up.
 - d) Using a #3 Phillips screwdriver, fasten the door frame to the door latches with the two (2) latch screws. The latches should pull forward to engage the door frame.

Note: Securely tighten latch screws when reinstalling glass door assembly.

- 2) Install the modesty panel on the top flange of the glass door, as follows:
 - a) Grasp the modesty panel with both hands (with the open hem facing down).
 - b) Engage it with the upper lip of the glass door frame by pushing it all the way down. Make sure the installed modesty panel is firmly in place.
- 3) Install the mesh pull screens, as follows:
 - a) Retrieve the rod and two mesh pull screens. If necessary, attach screens to rod.
 - b) Slowly insert the right end of the rod into the hole in the right rod bracket.
 - c) Insert the left end of the rod into the slot in the left rod bracket.

Removing Glass Doors, Mesh Pull Screens, and Modesty Panel (see Figure 48)

- 1) Remove the mesh pull screens, as follows:
 - a) Lift up the left end of the rod to disengage it from the slot in the left rod bracket.
 - b) Slowly remove the right end of the rod from the hole in the right rod bracket.
 - c) Set aside the rod and mesh pull screens for later reinstallation.
- 2) Remove the modesty panel from the top flange of the glass door by firmly pulling up on it with both hands until it is disengaged.
- 3) Remove one of the glass doors, as follows:
 - a) See **Figure 48**. While holding the top of the glass door frame in place, use a #3 Phillips screwdriver to remove the two (2) screws securing the door frame to the two (2) door latches.
 - b) Carefully tilt the top of the glass door frame away from the unit (as shown in **Figure 48**), and then lift the door assembly up and out of the lower track.
 - c) Carefully place the glass door assembly on a padded surface in a safe location to prevent damage.

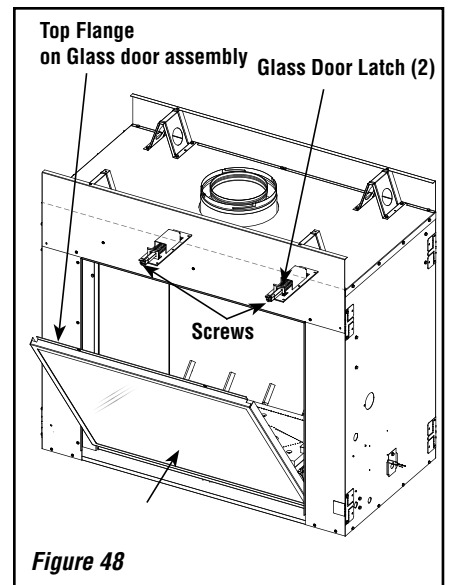

Figure 48

Step 11. BURNER ADJUSTMENTS

Flame Appearance and Sooting

Proper flame appearance is a flame that is blue at the base and becomes yellowish-orange in the body of the flame. When the appliance is first lit, the entire flame may be blue and will gradually turn yellowish-orange during the first 30 minutes of operation. After 30 minutes of operation, if the flame is blue, or if the flame is orange with evidence of sooting (black tip), the air shutter opening may need to be adjusted.

If the air shutter opening is closed too far, sooting may develop. Sooting is indicated by black puffs developing at the tips of very long orange flames. Sooting results in black deposits forming on the logs, appliance inside surfaces and on exterior surfaces adjacent to the vent termination.

Sooting is caused by incomplete combustion in the flames and lack of combustion air entering the air shutter opening. To achieve a warm yellowish-orange flame with an orange body that does not soot, the shutter opening must be adjusted between these two extremes.

Air Shutter Adjustment Guidelines

- If there is smoke or soot present, first check the log set positioning to ensure that the flames are not impinging on any of the logs. If the log set is properly positioned and a sooting condition still exists, then the air shutter opening should be increased.
- The more offsets in the vent system, the larger the air shutter opening will need to be.
- An appliance operated with the air shutter opened too far, may have flames that appear blue and transparent. These weak, blue and transparent flames are termed anemic.
- Propane models may exhibit flames which candle or appear stringy. If this is present and persists, adjust the air shutter to a more OPEN position, then operate the appliance for a few more minutes to ensure that the flame normalizes and the flames do not appear sooty.

The following chart is provided to aid you in achieving the correct air shutter adjustment for your installation.

Air Shutter Adjustment Guidelines:		
Amount of Primary Air	Flame Color	Air Shutter Adjustment
If air shutter is closed too far →	Flame will be orange →	Air shutter gap should be increased
If air shutter is open too far →	Flame will be blue →	Air shutter gap should be decreased

Burner Air Shutter Adjustment Procedure

⚠ WARNING

**HOT GLASS WILL CAUSE BURNS.
DO NOT TOUCH GLASS UNTIL COOLED.**

- Fireplace surfaces get **EXTREMELY HOT!**
- The glass on the front of the fireplace reaches **EXTREMELY HIGH temperatures and can cause severe burns if touched. Even after the gas is turned off, fireplace surfaces remain extremely hot.**

⚠ CAUTION

**RISK OF PERSONAL INJURY
OR PROPERTY DAMAGE.**

- Air shutter adjustment should only be performed by a qualified professional service technician.
- Soot will be produced if the air shutter is closed too much. Any damage due to carboning resulting from improperly setting the air shutter is not covered under the warranty.

1. Light the appliance (follow lighting procedure in *Care and Operation Instructions* or on lighting label in control compartment).
2. Allow the burner to operate for at least 30 minutes while continuously observing the flame to ensure that the proper flame appearance has been achieved (see **Figures 49 and 50**).
3. Adjust the air shutter using the lever on the lower right side of the firebox on the control side (**Figure 49**).
 - For more **OPEN** air shutter, slide lever to the **RIGHT**.
 - For more **CLOSED** air shutter, slide lever to the **LEFT**.

A minimum shutter setting is designed into the venturi by four 1/16"-inch tabs.

- If the flame appears weak or sooty (as described on the previous page), adjust the air shutter until proper flame appearance is achieved.
- If flame stays lowered blue, **incrementally** adjust the air shutter to a more **CLOSED** position until proper flame appearance is achieved.

Note: See **Figures 49 and 50** for proper burner flame appearance.

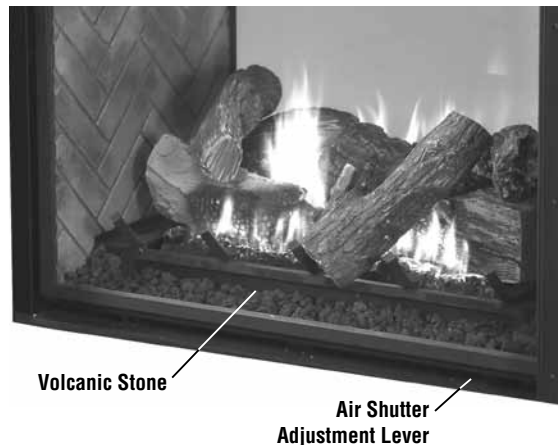

Figure 49: Burner Flame Appearance — Control Side



Figure 50: Burner Flame Appearance — Opposite Control Side

NOTE: DIAGRAMS & ILLUSTRATIONS ARE NOT TO SCALE.

FINISHING REQUIREMENTS

Wall Details - INDOOR SIDE(S)

Complete the finished interior wall. To install the appliance facing flush with the finished wall, position framework to accommodate the thickness of the finished wall (**Figure 51**).

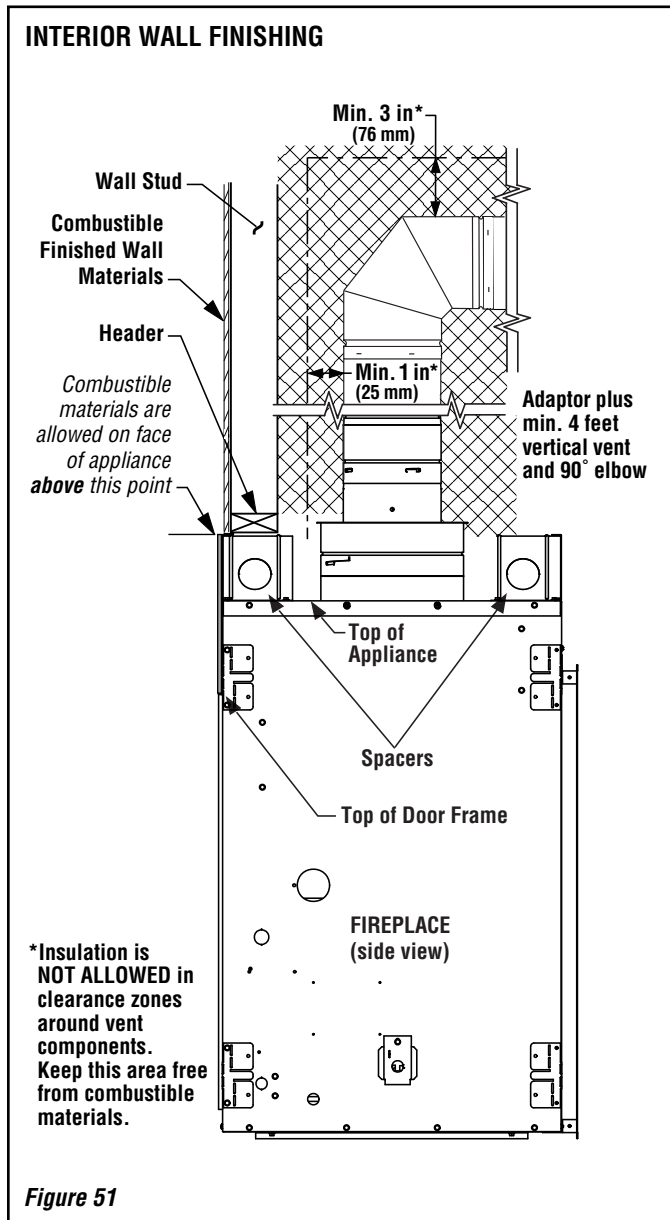

Wall Details - OUTDOOR SIDE

Complete finished exterior wall per the instructions provided in the Outdoor Installation Kit and the instructions provided here. To install the appliance facing flush with the finished exterior wall, position framework to accommodate the thickness of the exterior finished wall (**Figure 52**).

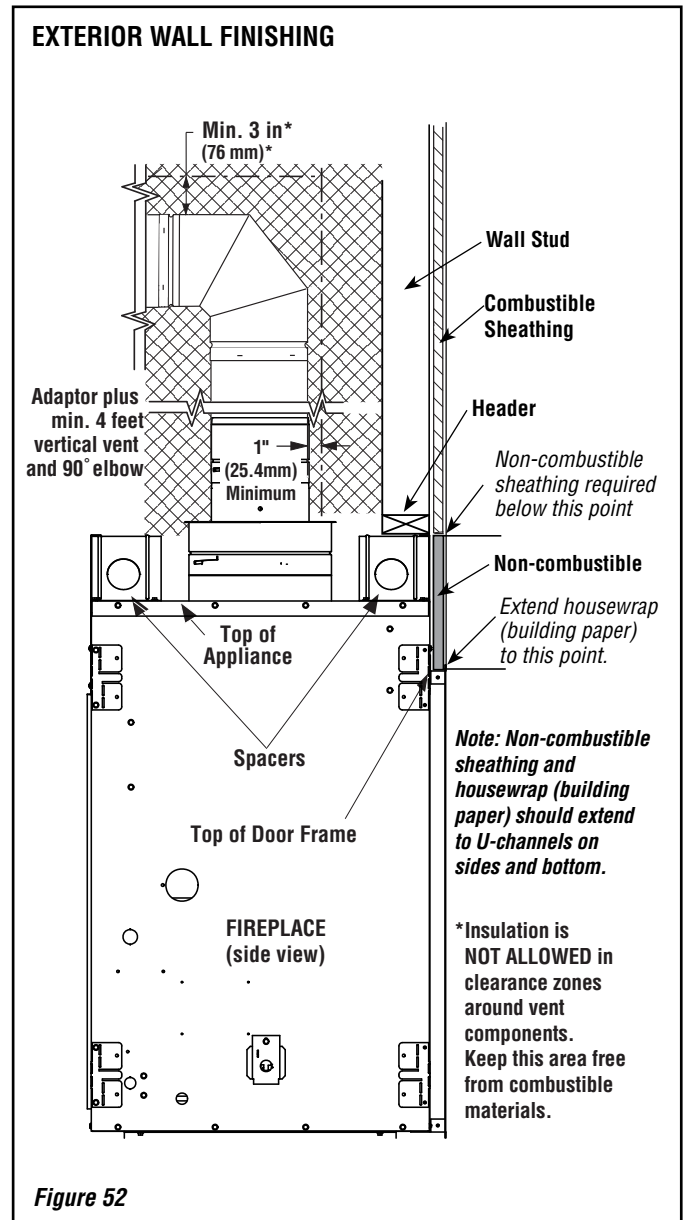

See Page 5 for Cold Climate Insulation and Page 9 for Clearances

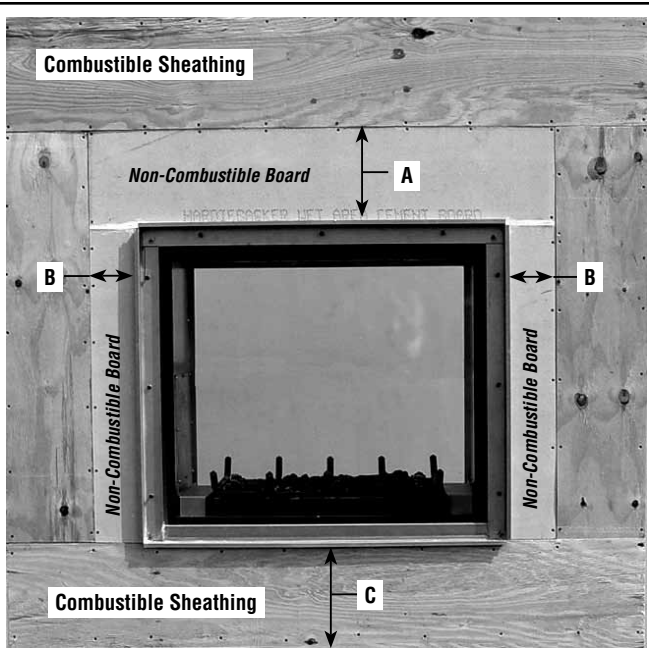

Sheathing Requirements		
A	B	C*
12" (305mm)	7" (178mm)	6" (152mm)

**Dimension "C" is clearance required from fireplace base to surface (e.g., deck, patio, lanai) as a moisture barrier (not a combustible clearance) on outdoor side only.*

Figure 53: Sheathing

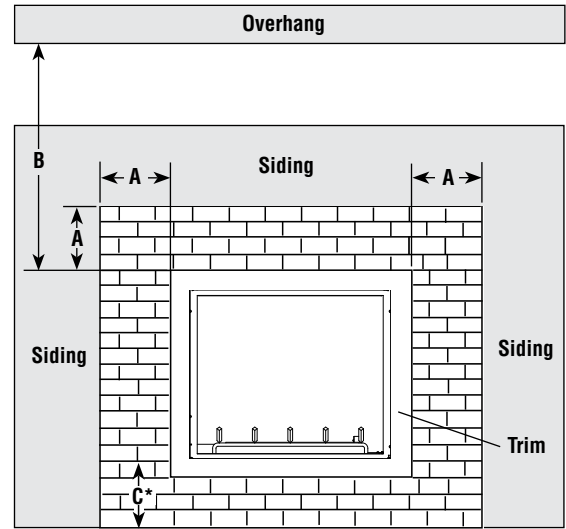

Exterior Minimum Clearances			
Material	A	B	C*
Vinyl	12" (305mm)	35-1/2" (902mm)	6" (305mm)
Non-Vinyl	7" (178mm)	35-1/2" (902mm)	6" (305mm)

**Dimension "C" is clearance required from fireplace base to surface (e.g., deck, patio, lanai) as a moisture barrier (not a combustible clearance) on outdoor side only.*

Figure 54: Exterior Clearances

Step 12. ATTACHING SAFETY-IN-OPERATION WARNINGS

It is the installer's responsibility to ensure these warnings are properly affixed during installation. These warning labels are a critical step in informing consumers of safe operation of this appliance.

ATTACHING SAFETY-IN-OPERATION WARNINGS

It is required that the set of safety instruction labels that have been furnished with the fireplace be affixed to the operation and control points of the fireplace. A safety instruction label must be affixed to the receiver wall switch plate where the fireplace is turned on and off (See **Figure A**) and on the remote control handheld transmitter (See **Figure B**). To properly complete the installation of this fireplace, locate the multi-lingual adhesive labels provided with the Care and Operation Instructions and proceed as follows:

1. Locate the wall receiver that controls the fireplace (verify the switch operates the fireplace by turning it on and off). Clean the wall receiver plate thoroughly to remove any dust and oils. Affix the label to the surface of the plate of the wall receiver that controls the fireplace (**Figure A**). Choose the language primarily spoken in the home. If unknown, affix the English language label.
2. Locate the remote control transmitter and clean it thoroughly to remove any dust and oils. Affix the label to the surface of handheld transmitter (**Figure B**). Choose the language primarily spoken in the home. If unknown, affix the English language label.
3. If you are unable to locate the labels, please call Lennox Hearth Products or your nearest Lennox Hearth Products dealer to receive additional safety instruction labels free of charge.

Cat. No. H8024 Replacement Label Kit

LENNOX HEARTH PRODUCTS

1-800-9-LENNOX

Note: English is red text on clear label. French and Spanish are white text on black label.

APPOSITION DES MISES EN GARDE RELATIVES À LA SÉCURITÉ D'UTILISATION

Il est impératif que le jeu d'étiquettes de sécurité qui ont été fournies avec le foyer soient collées à côté des dispositifs de contrôle du foyer. Une étiquette de sécurité doit être collée sur la plaque du récepteur mural contrôlant l'allumage du foyer (voir **Figure A**) et sur le boîtier de la télécommande (**Figure B**). Pour achever l'installation correcte de ce foyer, procédez comme suit avec les étiquettes adhésives en langues étrangères fournies avec les instructions d'utilisation et d'entretien :

1. Repérez le récepteur mural qui contrôle le foyer (vérifiez que l'interrupteur contrôle le fonctionnement du foyer en le faisant basculer de Marche à Arrêt, et vice-versa). Nettoyez soigneusement la plaque du récepteur mural pour éliminer la poussière et les traces de graisse ou d'huile. Collez l'étiquette sur la surface de la plaque du récepteur mural qui contrôle le foyer (**Figure A**). Choisissez la langue qui est principalement parlée dans la résidence du propriétaire. En cas de doute, collez l'étiquette en anglais.
2. Repérez la télécommande et nettoyez-la soigneusement pour éliminer la poussière et les traces de graisse ou d'huile. Collez l'étiquette sur le boîtier de la télécommande (**Figure B**). Choisissez la langue qui est principalement parlée dans la résidence du propriétaire. En cas de doute, collez l'étiquette en anglais.
3. Si vous ne trouvez pas les étiquettes, veuillez appeler Lennox Hearth Products ou votre distributeur Lennox Hearth Products local pour recevoir gratuitement des étiquettes supplémentaires.

Étiquettes de remplacement, n° cat. H8024

LENNOX HEARTH PRODUCTS

1-800-9-LENNOX

Remarque : Le texte anglais est rouge sur un support transparent. Le texte français et espagnol est blanc sur un support noir.

COLOCACIÓN DE ADVERTENCIAS DE SEGURIDAD EN OPERACIÓN

Se requiere que el juego de etiquetas de instrucciones de seguridad que se incluyeron con la chimenea se coloquen en los puntos de operación y control de la misma. Se debe colocar una etiqueta de instrucciones de seguridad en la placa del interruptor de pared del receptor desde el cual se enciende y se apaga la chimenea (ver la **Figura A**) y en el transmisor de control remoto (ver la **Figura B**). Para completar correctamente la instalación de esta chimenea, encuentre las etiquetas adhesivas multilingües incluidas con las instrucciones de cuidado y operación y haga lo siguiente:

1. Identifique el receptor de pared que controla la chimenea (verifique que el interruptor opera la chimenea encendiéndola y apagándola). Limpie bien la placa del receptor de pared para quitar el polvo y aceite. Pegue la etiqueta en la superficie de la placa del receptor de pared que controla la chimenea (**Figura A**). Seleccione el idioma que más se habla en la casa. Si no sabe cuál es, use la etiqueta en inglés.
2. Identifique el transmisor de control remoto y límpielo bien para quitar el polvo y aceite. Pegue la etiqueta en la superficie del transmisor (**Figura B**). Seleccione el idioma que más se habla en la casa. Si no sabe cuál es, use la etiqueta en inglés.
3. Si no puede encontrar las etiquetas, sírvase llamar a Lennox Hearth Products o al distribuidor de Lennox Hearth Products más cercano para recibir etiquetas de instrucciones de seguridad adicionales gratuitas.

Juego de etiquetas de repuesto - N° de cat. H8024

LENNOX HEARTH PRODUCTS

1-800-9-LENNOX

Nota: La etiqueta en inglés es transparente con texto rojo. Las etiquetas en francés y español son negras con texto blanco.

SAFETY LABEL DIAGRAMS



DIAGRAMMES DES ÉTIQUETTES DE SÉCURITÉ



DIAGRAMAS DE ETIQUETAS DE SEGURIDAD

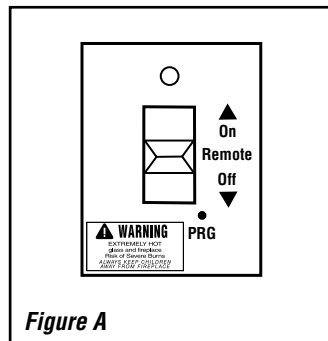
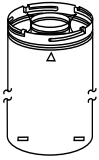
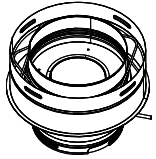
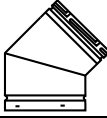
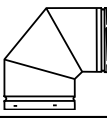
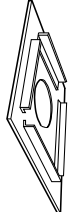
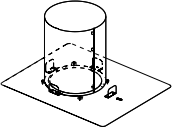
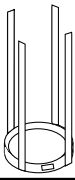
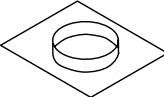



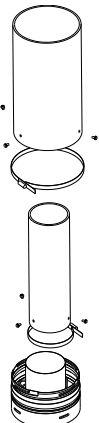
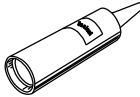

Figure A

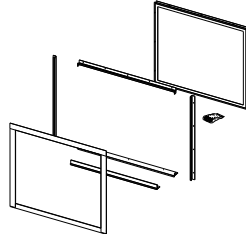

Figure B

INSTALLATION ACCESSORIES

Listed Secure Vent™ Components			
	Cat. No.	Model No.	Description
	77L70	SV4.5L6	Vent Section, 6 inch (152mm)
	77L71	SV4.5L12	Vent Section, 12 inch (305mm)
	77L72	SV4.5L24	Vent Section, 24 inch (610mm)
	77L73	SV4.5L36	Vent Section, 36 inch (914mm)
	77L74	SV4.5L48	48 inch (1219mm) Vent Section
	77L75	SV4.5LA	Telescopic Section
	H8313	—	Adaptor/Probe Assembly
	77L76	SV4.5E45	45 Degree Elbow
	77L77	SV4.5E90	90 Degree Elbow
	H2246	SV4.5HF	Firestop/Spacer, Horizontal (3-1-1 spacing) 10 pack
	H2247	SV4.5VF	Firestop/Spacer, Vertical (1-1-1 spacing) 10 pack
The following flashings come packaged with a storm collar:			
	H5816	SV4.5-TWSK	Through Wall Shield Kit (used to shield direct-vent pipe from blown insulation) Ref. doc. P/N 750247M
	96K93	SV4.5SU	Support Strap
	96K92	SV4.5SP	Support Plate

Listed Secure Vent™ / Secure Flex™ Components			
	Cat. No.	Model No.	Description
	H3907	SV4.5RSA	Attic Insulation Shield (adjustable 12" to 22")
	H7748	FVK36	36" Flex Vent Kit <i>Note: Flex attaches to appliance collar at one end and to rigid venting at the other end.</i>
	10K81	SFMP	Mill-Pac, Black, High-Temperature Sealant
	89L40	SFMP-12	Mill-Pac, Black, High Temperature Sealant (Bulk 12 pack)
	91L66	SF-GC4-6	Gear Clamp 4.5 in. (114 mm) for flex (6 pieces)
	91L67	SF-GC7-6	Gear Clamp 7.5 in. (190.5 mm) for flex (6 pieces)

	Outdoor Kits		
	H7940	LSM40STODK	Outdoor Kit with Light-tint Glass
	H8061	LSM40ST-ODKT	Outdoor Kit with Dark-tint Glass
<i>(Outdoor Kit Instructions P/N 506019-20)</i>			

GAS CONVERSION KITS

Gas conversion kits are available to adapt your appliance from the use of one type of gas to another. These kits contain all the necessary components needed to complete the task, including labeling that must be affixed to ensure safe operation.

Kit part numbers are listed at right.

Refer to the instructions provided with the conversion kit when performing any gas conversion.

Gas Conversion Kits		
Kit Model No.	Kit Cat. No.	Description
GCK-NP-LSM40ST	H7951	Natural Gas to Liquid Propane Conversion Kit
GCK-PN-LSM40ST	H7952	Liquid Propane to Natural Gas Conversion Kit
Table 10		<i>(Gas Conversion Kit Instructions P/N 506019-53)</i>

Lennox Hearth Products reserves the right to make changes at any time, without notice, in design, materials, specifications, and prices, and also to discontinue colors, styles, and products. Consult your local distributor for fireplace code information.



Printed in U.S.A. © 2011 Lennox Hearth Products

P/N 506023-10 Rev. B 05/2011

1508 Elm Hill Pike, Suite 108 • Nashville, TN 37210