

WRT4826

 CUSTOM WOOD EPA BURNING FIREPLACES

Superior[™]
FIREPLACES
Our name is our promise.



TRADITIONAL

“Impressive” is the only way to describe these massive wood-burners. Designed for large, custom applications the WRT4826 Custom Wood Burning Fireplaces feature a 30” tall opening and beautiful brick panels that mimic a masonry fireplace.



FEATURED WRT4826 with White Herringbone Textured Panels and clean face panel kit.

EXCLUSIVE FEATURES

- 🔥 Circulating louvered design features ceramic glass for optimum heat transfer (optional clean-face kit available)
- 🔥 EPA phase II certified and Washington State approved wood heater
- 🔥 3.8 cubic foot insulated firebox that accepts up to 20" log size for increased performance
- 🔥 White herringbone textured refractory panels with integrated ash lip and decorative cast iron log retainer
- 🔥 Air combustion control for variable heat output with air boost for faster wood ignition during startup
- 🔥 Catalytic combustor for maximum performance with bypass control
- 🔥 Includes insulated outside air kit (required for use)
- 🔥 75% thermal efficiency and heats up to 2,500 square feet*
- 🔥 Efficient air wash system that keeps glass clean
- 🔥 Cast iron door with heat resistant door handle that stays cool to the touch
- 🔥 Optional heat activated 200 CFM UZY-5 variable speed blower for time-delayed heat distribution
- 🔥 Dual ducted gravity kit (required when using clean-face kit) and/or thermostatically controlled forced air kit available (3 maximum outlets)
- 🔥 Durable high temperature paint finish
- 🔥 Uses SCIL (ACBI) 7" air cooled wood burning chimney
- 🔥 Uses SCIL (ASHT / HT6103 / S-2100 / HT6000) 7" insulated wood burning chimney
- 🔥 20 year limited warranty

OPTIONAL ACCESSORIES

- 🔥 Black Arch Door (Required)
- 🔥 Del Sol, Diamante or Strada Louver Kits (One Required)
- 🔥 Clean-Face Kit
- 🔥 Rigid Fire Screen
- 🔥 Double Duct Gravity Kit (Required for Clean-Face Kit)
- 🔥 Forced Air Kit
- 🔥 Heat Activated Blower
- 🔥 Variable Speed Switch for Blower

CATALYTIC COMBUSTION

The WRT4826 fireplace's catalytic combustion helps increase efficiency and save energy. It produces more heat using less wood and gives you longer burn times for heating buildup by 90%, thereby greatly minimizing a major cause of chimney fires. Engineered with a secondary burn and catalytic combustion for burn-off gases, the WRT4826 fireplace offers maximum energy efficiency while consuming less fuel. It's an investment that pays for itself over time.



- 1** Single door provides an unobstructed panoramic view of the flames
- 2** Dual-handle ash drawer with lid
- 3** Air intake lever allows better combustion control, producing from 10,000 to 70,000 BTU/hr.
- 4** Bypass control overrides the catalyst combustor restrictive passageway when opening the door
- 5** White Herringbone Textured Panels

DECORATIVE GRILL OPTIONS

(Optional)



Del Sol



Diamante



Strada

ENGINEERING FEATURES AND SPECIFICATIONS

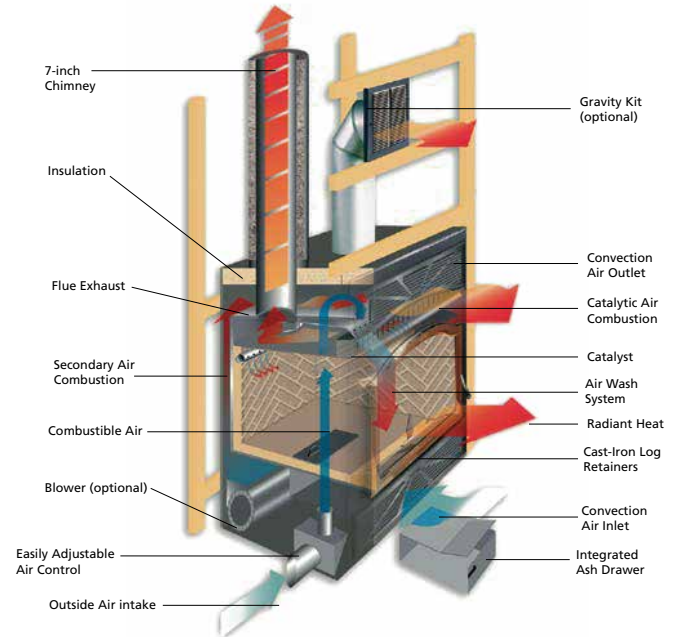

BURN RATES*

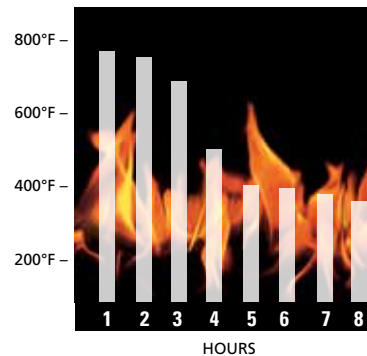

*Results obtained by burning 25 lbs. of dry maple wood. (one hour pre-heating)

APPLIANCE SPECIFICATIONS

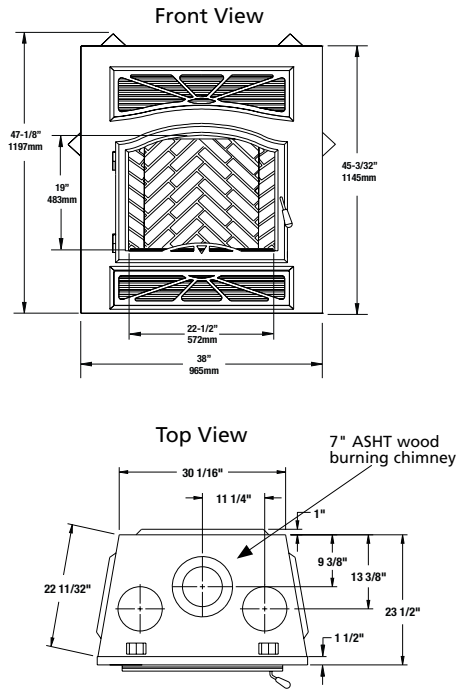

Right Side View

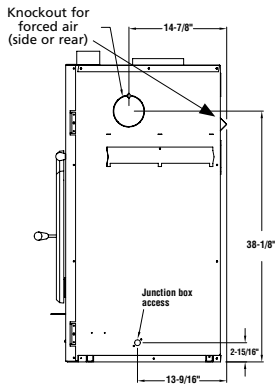

Left Side View

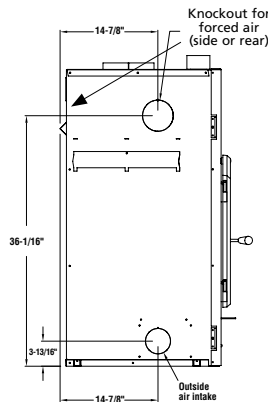

IMPORTANT NOTES:

As with any fireplace, this appliance is extremely hot during operation. Read and understand all operating instructions before using this appliance. For further information, consult your dealer.

Local conditions, such as elevation and choice of fuel will affect overall appearance of the fire and heating performance. Performance can also vary with home design and insulation, ceiling height, accessories chosen and appliance location.

Diagrams, illustrations and photographs are not to scale — consult installation instructions. Product designs, materials, dimensions, specifications, colors and prices are subject to change or discontinuance without notice.

INSTALLATION SPECIFICATIONS

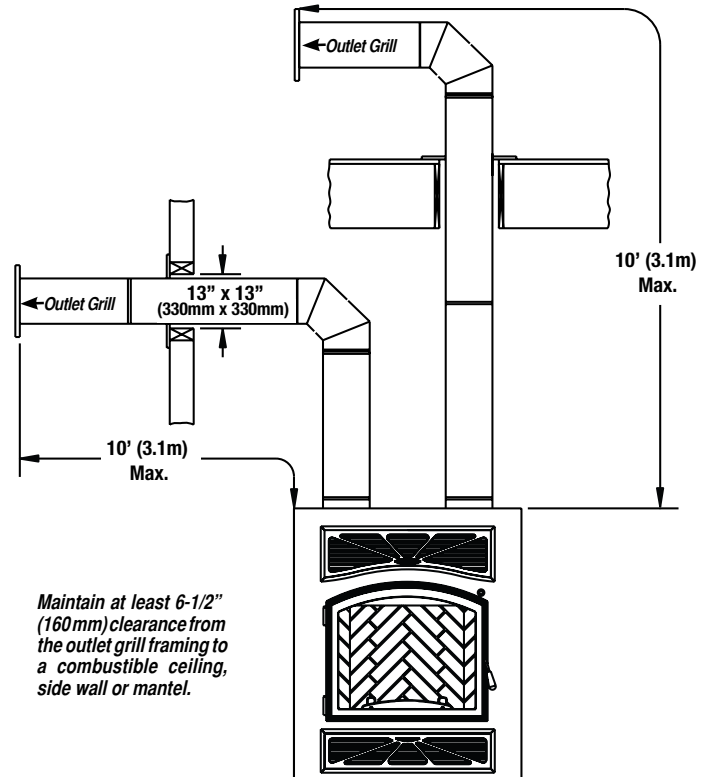

PRODUCT SPECIFICATIONS

Glass Viewing Area (W x H)	22-1/2" x 19"
Firebox Interior (W x H x D+)	22" x 20" x 15"
Interior Cubic Feet	3.8
Maximum Log Size	20"
Chimney Size	7"
EPA Rating	4.0 grams/hr
BTU's	70,000
Heating Capacity (up to)	2,500 sq. ft.
Thermal Efficiency	75%
Blower	200 CFM
Weight	403 lbs.

+Measured in front of door



© 2014 Innovative Hearth Products

785375M 07/14

Visit us online



SuperiorFireplaces.us.com

