



INSTALLATION AND OPERATION MANUAL

Fiberglow™ Series

SAFETY INFORMATION

⚠ WARNING

FIRE OR EXPLOSION HAZARD

Failure to follow safety warnings exactly could result in serious injury, death, or property damage.

- Do not store or use gasoline or other flammable vapors and liquids in the vicinity of this or any other appliance.

- WHAT TO DO IF YOU SMELL GAS:

- Do not try to light any appliance.
- Do not touch any electrical switch; do not use any phone in your building.
- Immediately call your gas supplier from a neighbour's phone. Follow the gas supplier's instructions.
- If you cannot reach your gas supplier, call the fire department.

- Installation and service must be performed by a qualified installer, service agency, or the supplier.

- This is an unvented gas-fired heater that uses air (oxygen) from the room in which it is installed. Provisions for adequate combustion and ventilation air must be provided. Refer to section "combustion and ventilation air provisions".

This appliance may be installed in an aftermarket, permanently located, manufactured-home (USA only) or mobile home, where not prohibited by local codes.

This appliance is only for use with the type of gas indicated on the rating plate. This appliance is not convertible for use with other gases.

INSTALLER:

Leave this manual with the appliance

CONSUMER:

Retain this manual for future reference

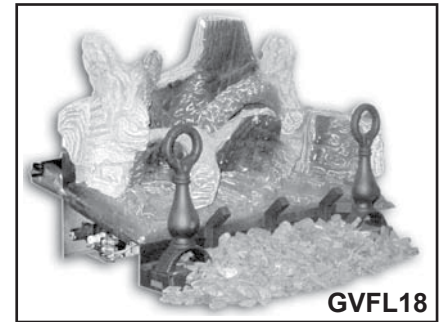

GVFL18



GVFL24

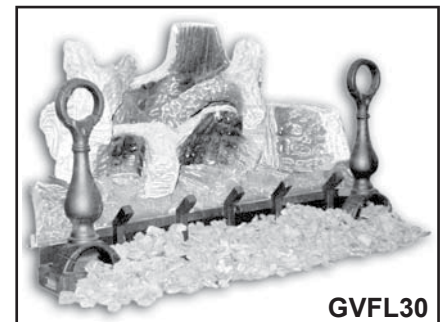

GVFL30

FOR INDOOR USE ONLY

CERTIFIED TO: ANSI Z21.11.2 UNVENTED HEATERS
ANSI Z21.60 / CSA 2.26 DECORATIVE GAS APPLIANCES FOR INSTALLATION IN SOLID-FUEL BURNING APPLIANCES

These log sets can be installed in vented or unvented applications.

APPLY SERIAL NUMBER LABEL FROM CARTON



Serial No. XXXXX00000
MODEL NO.



BARRIER



Wolf Steel Ltd., 24 Napoleon Rd., Barrie, ON, L4M 0G8 Canada / 103 Miller Drive, Crittenden, Kentucky, USA, 41030
Phone 1 (866) 820-8686 • www.napoleon.com • hearth@napoleon.com

WARNING

- **This appliance is hot when operated and can cause severe burns if contacted.**
- **Any changes or alterations to this appliance or its controls can be dangerous and is prohibited.**
- Do not operate appliance before reading and understanding operating instructions. Failure to operate appliance according to operating instructions could cause fire or injury.
- Ensure the glass door is opened or removed when lighting the pilot for the first time and when the gas supply has run out.
- Risk of fire or asphyxiation, do not operate appliance with fixed glass removed and never obstruct the front opening of the appliance.
- Do not connect 110 volts to the control valve, with the exception of models; GSST8 and GT8.
- Risk of burns. The appliance should be turned off and cooled before servicing.
- Do not install damaged, incomplete or substitute components.
- Risk of cuts and abrasions. Wear protective gloves, protective footwear, and safety glasses during installation. Sheet metal edges may be sharp.
- Do not burn wood or other materials in this appliance.
- Provide adequate ventilation and combustion air. Provide adequate accessibility clearance for servicing and operating the appliance.
- High pressure will damage valve. Disconnect gas supply piping before pressure testing gas line at test pressures above 1/2 psig. Close the manual shut-off valve before pressure testing gas line at test pressures equal to or less than 1/2 psig (35mb).
- The appliance must not be operated at temperatures below freezing (32°F / 0°C). Allow the appliance to warm to above freezing prior to operation, with the exception of models; GSS36, GSS42; these appliances are suitable for 0°F / -18°C.
- **Children and adults should be alerted to hazards of high surface temperature and should stay away to avoid burns or clothing ignition.**
- **Young children should be carefully supervised when they are in the same room as the appliance. Toddlers, young children and others may be susceptible to accidental contact burns. A physical barrier is recommended if there are at risk individuals in the house. To restrict access to an appliance or stove, install an adjustable safety gate to keep toddlers, young children and other at risk individuals out of the room and away from hot surfaces.**
- **Clothing or other flammable material should not be placed on or near the appliance.**
- **Due to high temperatures, the appliance should be located out of traffic and away from furniture and draperies.**
- Furniture or other objects must be kept a minimum of 4 feet (1.22m) away from the front of the appliance.
- Ensure you have incorporated adequate safety measure to protect infants/toddlers from touching hot surfaces.
- Even after the appliance is off, it will remain hot for an extended period of time.
- Check with your local hearth specialty dealer for safety screens and hearth guards to protect children from hot surfaces. These screens and guards must be fastened to the floor.
- **Any safety screen, guard or barrier removed for servicing the appliance, must be replaced prior to operating the appliance.**
- It is imperative that the control compartments, burners and circulating blower and its passageway in the appliance and venting system are kept clean. The appliance and its venting system should be inspected before use and at least annually by a qualified service person. More frequent cleaning may be required due to excessive lint from carpeting, bedding material, etc. The appliance area must be kept clear and free from combustible materials, gasoline and other flammable vapors and liquids.
- If the appliance shuts off, do not re-light until you provide fresh air. If appliance keeps shutting off, have it serviced. Keep burner and control compartment clean.
- Under no circumstances should this appliance be modified.
- Do not allow wind or fans to blow directly into the appliance. Avoid any drafts that alter burner flame patterns.



DANGER



HOT GLASS WILL CAUSE BURNS.

DO NOT TOUCH GLASS UNTIL COOLED.

NEVER ALLOW CHILDREN TO TOUCH GLASS.

A barrier designed to reduce the risk of burns from the hot viewing glass is provided with this appliance and must be installed for the protection of children and other at-risk individuals.





WARNING: FIRE, EXPLOSION, AND ASPHYXIATION HAZARD

Improper adjustment, alteration, service, maintenance, or installation of this heater or its controls can cause death or serious injury.
Read and follow instructions and precautions in User's Information Manual provided with this heater.

WARNING

- Do not use a blower insert, heat exchanger insert or other accessory not approved for use with this appliance.
- This appliance must not be connected to a chimney flue pipe serving a separate solid fuel burning appliance.
- Do not use this appliance if any part has been under water. Immediately call a qualified service technician to inspect the appliance and to replace any part of the control system and any gas control which has been under water.
- Do not operate the appliance with the glass door removed, cracked or broken. Replacement of the glass should be done by a licensed or qualified service person, if equipped.
- Do not strike or slam shut the appliance glass door, if equipped.
- **Only doors / optional fronts certified with the appliance are to be installed on the appliance.**
- Keep the packaging material out of reach of children and dispose of the material in a safe manner. As with all plastic bags, these are not toys and should be kept away from children and infants.
- Carbon or soot should not occur in a vent free appliance as it can distribute into the living area of your home. If you notice any signs of carbon or soot, immediately turn off your appliance and arrange to have it serviced by a qualified technician before operating it again.
- If equipped, the screen must be in place (closed) when the appliance is in operation.
- When equipped with pressure relief doors, they must be kept closed while the appliance is operating to prevent exhaust fumes containing carbon monoxide, from entering into the home. Temperatures of the exhaust escaping through these openings can also cause the surrounding combustible materials to overheat and catch fire.
- Carbon monoxide poisoning may lead to death; early signs of carbon monoxide poisoning resemble the flu, with headache, dizziness and/or nausea. If you have these signs, the appliance may not be working properly. Get fresh air at once! Have appliance serviced. Some people; pregnant women, persons with heart or lung disease, anemia, those under the influence of alcohol, those at high altitudes are more affected by carbon monoxide than others. Failure to keep the primary air opening(s) of the burner(s) clean may result in sooting and property damage.
- As with any combustion appliance, we recommend having your appliance regularly inspected and serviced as well as having a Carbon Monoxide Detector installed in the same area to defend you and your family against Carbon Monoxide (not applicable for outdoor appliances).
- Ensure clearances to combustibles are maintained when building a mantel or shelves above the appliance. Elevated temperatures on the wall or in the air above the appliance can cause melting, discolouration or damage to decorations, a TV or other electronic components.
- **For appliances equipped with a safety barrier; if the barrier becomes damaged, the barrier shall be replaced with the manufacturer's barrier for this appliance.**
- **Installation and repair should be done by a qualified service person. It is imperative that control compartments, burners and circulating air passageways of the appliance be kept clean.**
- For outdoor products only: this appliance must not be installed indoors or within any structure that prevents or inhibits the exhaust gases from dissipating in the outside atmosphere.
- If applicable, the millivolt version of this appliance uses and requires a fast acting thermocouple. Replace only with a fast acting thermocouple supplied by Wolf Steel Ltd.

⚠ WARNING: This product can expose you to chemicals including lead and lead compounds, which are known to the State of California to cause cancer, and chemicals including carbon monoxide, which are known to the State of California to cause birth defects or other reproductive harm. For more information, go to www.P65Warnings.ca.gov.

 **WARNING** 

FIRE RISK HAZARD / DELAYED IGNITION

High supply pressure will damage the valve / controls.



Disconnect the appliance main gas valve/control from the supply piping when pressure testing that system at pressures in excess of 1/2 psi (3.5 kPa).

Isolate the appliance with its shut off valve during any pressure testing of the supply piping at pressures equal to or less than 1/2 psi (3.5 kPa).



table of contents

1.0	general information	5
1.1	minimum appliance size	5
1.2	general instructions	6
1.3	rating plate information	7
2.0	dimensions	8
3.0	installation	9
3.1	installation in an unvented application	9
3.1.1	combustion and ventilation air provisions	9
3.1.2	determining confined or unconfined space	9
3.2	installing in a vented application	10
3.2.1	damper stop installation	10
3.3	gas piping	11
4.0	finishing	12
4.1	andiron and grate assembly	12
4.2	log placement	13
4.3	logo placement	14
4.4	media	14
5.0	operating instructions	15
5.1	lighting instructions	15
5.2	match lighting instructions	15
6.0	operation	16
7.0	adjustments	17
7.1	air shutter	17
7.2	flame characteristics	17
7.3	flame height adjustment	17
8.0	maintenance	18
8.1	oxygen depletion sensor (ODS) cleaning	18
9.0	replacement parts	19
10.0	accessories	21
11.0	troubleshooting	22
12.0	warranty	24
13.0	service history	25

NOTE: Changes, other than editorial, are denoted by a vertical line in the margin.

! WARNING

- Carbon monoxide poisoning may lead to death.
- Early signs of carbon monoxide poisoning resemble the flu, with headache, dizziness and/or nausea. If you have these signs, the appliance may not be working properly. Get fresh air at once! Have appliance serviced.
- Some people - pregnant women, persons with heart or lung disease, anemia, those under the influence, those at high altitudes - are more affected by carbon monoxide than others.
- This appliance must not be installed in a bedroom or bathroom.
- The appliance is only for use with the type of gas indicated on the rating plate.
- This appliance is not convertible for use with other gases.

WARNING
 This appliance is equipped for:
 Natural gas Propane
 Field conversion is not permitted.

	GVFL18		GVFL24		GVFL30	
	NG	P	NG	P	NG	P
Altitude (FT)	0-4,500		0-4,500		0-4,500	
Max input (BTU/HR)	40,000		40,000		40,000	
Min Inlet Gas Supply Pressure	4.5" Water Column	11" Water Column	4.5" Water Column	11" Water Column	4.5" Water Column	11" Water Column
Max Inlet Gas Supply Pressure	7" Water Column	13" Water Column	7" Water Column	13" Water Column	7" Water Column	13" Water Column
Manifold Pressure (Under Flow Conditions)	3.5" Water Column	10" Water Column	3.5" Water Column	10" Water Column	3.5" Water Column	10" Water Column

This appliance is for installation in a solid fuel burning fireplace or listed ventless firebox enclosures only.

No external electricity (110 volts or 24 volts) is required for the gas system operation.

This appliance is equipped with a pilot light safety system referred to as an oxygen depletion sensor (ODS) and is designed to turn off the appliance if not enough fresh air is available.

Napoleon's two vent free firebox enclosures the ZCVF 36/42 can be used to house all 3 of Napoleon's vent free log sets, the GVFL 18, 24 and 30.

This appliance is intended for supplemental heating.



NATIONAL FIREPLACE INSTITUTE
NFI
CERTIFIED
www.nficertified.org

We suggest that our gas hearth products be installed and serviced by professionals who are certified in the U.S. by the National Fireplace Institute® (NFI) as NFI Gas Specialists

1.1 minimum appliance size

LOG SET	HEIGHT	WIDTH	DEPTH
GVFL18	18"	24"	14"
GVFL24	18"	28"	14"
GVFL30	18"	34"	14"

Each gas log set must be installed into a appliance cavity with a minimum size.

Refer to the table to determine the appropriate minimum appliance size.

general information

1.2 general instructions

WARNING

- Always light the pilot whether for the first time or if the gas supply has ran out, with the glass door opened or removed.
- Provide adequate clearance for servicing and operating the appliance.
- Provide adequate ventilation.
- Never obstruct the front opening of the appliance.
- Objects placed in front of the appliance must be kept a minimum of 48" from the front face of the appliance.
- Surfaces around and especially above the appliance can become hot. Avoid contact when the appliance is operating.
- Fire risk. Explosion hazard.
- High pressure will damage valve. Disconnect gas supply piping before pressure testing gas line at test pressures above 1/2 PSIG. Close the manual shut-off valve before pressure testing gasline at test pressures equal to or less than 1/2 PSIG.
- Use only Wolf Steel approved optional accessories and replacement parts with this appliance. Using non-listed accessories (borders, doors, louvers, trims, gas components, venting components, etc.) could result in a safety hazard and will void the warranty and certification.

Thoroughly clean the chimney, flue and existing appliance before installing the new appliance into it. Do not burn solid fuels in any appliance that is equipped with this gas log set.

The installation of this appliance must conform with local codes or in the absence of local codes with the National fuel gas code ANSI Z.223.1 / NFPA 54.

Do not operate appliance in the presence of gasoline or other flammable liquids and vapours. Keep area clear of other combustible materials. The appliance and its shut off must be disconnected from the gas supply piping system before any pressure testing of the system is done.

Installation practices vary from region to region and it is important to know the specifics that apply to your area, For example: in Massachusetts State:

- The appliance off valve must be a "T" handle gas cock.
- The flexible connector must not be longer than 36 inches.
- The appliance is not approved for installation in a bedroom or bathroom unless the appliance is a direct vent sealed combustion product.
- Unvented room appliance shall be installed in accordance with 527 CMR 30.00 and 248 CMR 3.00 through 7.00.
- Sellers of unvented propane or natural gas-fired space/room appliances shall provide to each purchaser a copy of 527 CMR 30.00 upon the sale of the appliance from http://www.napoleonfireplaces.com/Webshare/installation_manuals/mass_requirements.pdf
- A carbon monoxide detector is required in all rooms containing gas fired appliances.

This appliance may be installed in an aftermarket, permanently located, manufactured (mobile) home, where not prohibited by local codes.

1.3 rating plate information

CERTIFIED TO: ANSI Z21.11.2-2019 UNVENTED HEATERS
 REMOVAL OF THIS MARKING WILL VOID THE COMPLIANCE OF THIS HEATER WITH ANSI Z21.11.2.
 STATE OR LOCAL CODES MAY ONLY ALLOW OPERATION OF THIS APPLIANCE IN A VENTED CONFIGURATION. CHECK YOUR STATE OR LOCAL CODES.

WARNING: IMPROPER INSTALLATION, ADJUSTMENT, ALTERATION, SERVICE OR MAINTENANCE CAN CAUSE PROPERTY DAMAGE, PERSONAL INJURY OR LOSS OF LIFE. REFER TO THE OWNER'S INFORMATION MANUAL PROVIDED WITH THIS APPLIANCE. FOR ASSISTANCE OR ADDITIONAL INFORMATION, CONSULT A QUALIFIED INSTALLER, SERVICE AGENCY OR THE GAS SUPPLIER. THIS APPLIANCE IS NOT FIELD CONVERTIBLE FOR USE WITH OTHER GASES.

WARNING: THIS APPLIANCE IS FOR INSTALLATION ONLY IN A SOLID-FUEL BURNING MASONRY OR UL 127 FACTORY-BUILT FIREPLACE OR IN A LISTED VENTLESS FIREBOX ENCLOSURE. IT HAS BEEN DESIGN CERTIFIED FOR THESE INSTALLATIONS. EXCEPTION: DO NOT INSTALL THIS APPLIANCE IN A FACTORY-BUILT FIREPLACE THAT INCLUDES INSTRUCTIONS STATING THAT IT HAS NOT BEEN TESTED OR SHOULD NOT BE USED WITH UNVENTED GAS LOGS.

WARNING: DO NOT ADD ANY MATERIAL TO THE APPLIANCE, WHICH WILL COME IN CONTACT WITH THE FLAMES, OTHER THAN THAT SUPPLIED BY THE MANUFACTURER WITH THE APPLIANCE.

WARNING: FAILURE TO POSITION THE PARTS IN ACCORDANCE WITH THESE DIAGRAMS OR FAILURE TO USE ONLY PARTS SPECIFICALLY APPROVED WITH THIS HEATER MAY RESULT IN PROPERTY DAMAGE OR PERSONAL INJURY. SEE MANUAL FOR FURTHER INFORMATION.

WARNING: DO NOT USE A BLOWER INSERT, HEAT EXCHANGER INSERT, OR OTHER ACCESSORY NOT APPROVED FOR USE WITH THIS HEATER.

WARNING: ANY GLASS DOORS SHALL BE COMPLETELY OPENED WHEN THE APPLIANCE IS IN OPERATION.

CAUTION: HOT WHILE IN OPERATION. DO NOT TOUCH. KEEP CHILDREN, CLOTHING, FURNITURE, GASOLINE AND OTHER LIQUIDS HAVING FLAMMABLE VAPOURS AWAY. FOR YOUR SAFETY: DO NOT STORE OR USE GASOLINE OR OTHER FLAMMABLE VAPORS AND LIQUIDS IN THE VICINITY OF THIS OR ANY APPLIANCE.

NATURAL GAS MODELS

<input type="checkbox"/> GVFL18N 40,000 BTU/h	<input type="checkbox"/> GVFL24N 40,000 BTU/h	<input type="checkbox"/> GVFL30N 40,000 BTU/h
--	--	--

PROPRANE MODELS

<input type="checkbox"/> GVFL18P 40,000 BTU/h	<input type="checkbox"/> GVFL24P 40,000 BTU/h	<input type="checkbox"/> GVFL30P 40,000 BTU/h
--	--	--

INPUT REDUCED INPUT
 ALTITUDE 0-2000FT (0-1570m)
 MANIFOLD PRESSURE 10" WATER COLUMN
 MINIMUM SUPPLY PRESSURE 11" WATER COLUMN
 MAXIMUM SUPPLY PRESSURE 13" WATER COLUMN
 SIT CONTROL #520638
 OPERATING PILOT OXYPROTECTOR #6411824

WHEN INSTALLING INTO A SOLID FUEL BURNING FIREPLACE:
 THE FIREPLACE CHIMNEY MUST HAVE A PERMANENT VENT OPENING TO ATMOSPHERE OF NOT LESS THAN 33.8" FOR GVFL18, 33.8" FOR GVFL24, 33.8" FOR GVFL30 OR AS DETERMINED BY THE MANUFACTURER'S INSTALLATION INSTRUCTIONS.
 FOR MINIMUM CHIMNEY FLUE, SEE INSTRUCTION MANUAL.

MINIMUM FIREPLACE SIZE			
UNIT	HEIGHT	WIDTH	DEPTH
GVFL18	18"	24"	14"
GVFL24	18"	28"	14"
GVFL30	18"	34"	14"

WHEN INSTALLING INTO A LISTED VENTLESS FIREBOX ENCLOSURE FOR GAS-FIRED UNVENTED DECORATIVE ROOM HEATER:
 AS A GAS FIRED UNVENTED ROOM HEATER, THIS UNIT REQUIRES ADEQUATE COMBUSTION AND VENTILATION AIR FOR SAFE OPERATION. THIS TYPE OF INSTALLATION IS NOT APPROVED FOR BEDROOMS, BATHROOMS AND BED SITTING ROOMS. KEEP BURNER AND CONTROL AREA CLEAN.
 Refer to the Intertek Directory of Building Products (<https://bpdirectory.intertek.com>) for detailed information

WOLF STEEL LTD.
 24 NAPOLEON ROAD, BARRIE, ONTARIO L4M 0G8 CANADA
 SERIAL NUMBER: GVFL

ANY RESULT CAUSING PROPERTY DAMAGE, IT BE DONE WITH THE GLASS DOOR OFF. TION INSTRUCTIONS.

DO NOT TURN THE GAS CONTROL KNOB. NEVER USE TOOLS. IF THE 3Y HAND, DO NOT TRY TO REPAIR IT. CALL A QUALIFIED SERVICE REPAIR MAY RESULT IN A FIRE OR EXPLOSION. PART HAS BEEN UN-QUALIFIED SERVICE LACE AND REPLACE 1 AND ANY GAS CON-TER.

OXYPROTECTOR

LIGHTING INSTRUCTIONS

WHEN LIGHTING AND RE-LIGHTING, THE GAS KNOB CANNOT BE TURNED FROM PILOT TO OFF UNLESS THE KNOB IS DEPRESSED.

- STOP! READ THE ABOVE SAFETY INFORMATION ON THIS LABEL.
- SET THE THERMOSTAT TO LOWEST SETTING.
- TURN OFF ALL ELECTRIC POWER TO THE FIREPLACE.
- OPEN THE LOWER ACCESS DOOR. TURN THE GAS KNOB CLOCKWISE TO OFF.
- WAIT FIVE (5) MINUTES TO CLEAR OUT ANY GAS. IF YOU SMELL GAS INCLUDING NEAR THE FLOOR, STOP! FOLLOW "5" IN THE ABOVE SAFETY INFORMATION ON THIS LABEL. IF YOU DON'T SMELL GAS GO TO THE NEXT STEP.
- FIND PILOT LOCATED IN FRONT OF BACK LOG.
- TURN GAS KNOB COUNTER-CLOCKWISE TO PILOT.
- DEPRESS AND HOLD GAS KNOB WHILE LIGHTING THE PILOT WITH THE PUSH BUTTON IGNITOR. KEEP KNOB FULLY DEPRESSED FOR ONE MINUTE, THEN RELEASE. IF PILOT DOES NOT CONTINUE TO BURN REPEAT STEPS 3 THROUGH 7.
- WITH PILOT LIT, TURN GAS KNOB COUNTER-CLOCKWISE TO ON. WHEN THE PILOT HAS BEEN TURNED OFF, IGNITION OF THE MAIN BURNER MAY BE DELAYED FOR 1-2 MINUTES. WHEN THE PILOT HAS BEEN LEFT BURNING, IGNITION OF THE MAIN BURNER SHOULD OCCUR ALMOST IMMEDIATELY.
- IF EQUIPPED WITH REMOTE ON-OFF SWITCH, MAIN BURNER MAY NOT COME ON WHEN YOU TURN THE VALVE TO ON. REMOTE SWITCH MUST BE IN THE ON POSITION TO IGNITE BURNER.
- TURN ON ALL ELECTRIC POWER TO THE FIREPLACE.

TO TURN OFF GAS

- TURN OFF ALL ELECTRIC POWER TO THE FIREPLACE IF SERVICE IS TO BE PERFORMED.
- PUSH IN GAS CONTROL KNOB SLIGHTLY AND TURN CLOCKWISE TO OFF, DO NOT FORCE.

THE RATING PLATE IS CHAINED TO THE PIEZO IGNITOR BRACKET AND SHOULD BE TUCKED UNDER THE ENTIRE ASSEMBLY

This illustration is for reference only. Refer to the rating plate on the appliance for accurate information.

2.0 dimensions

GVFL18

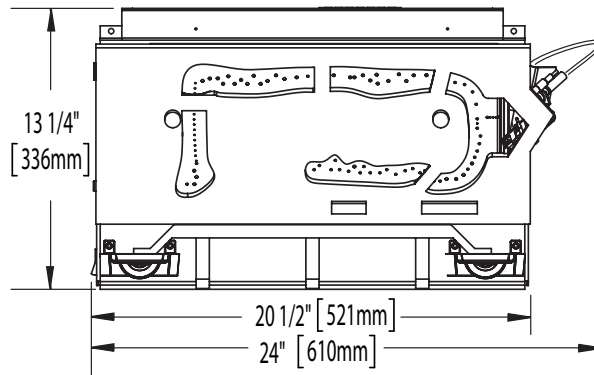

GVFL24

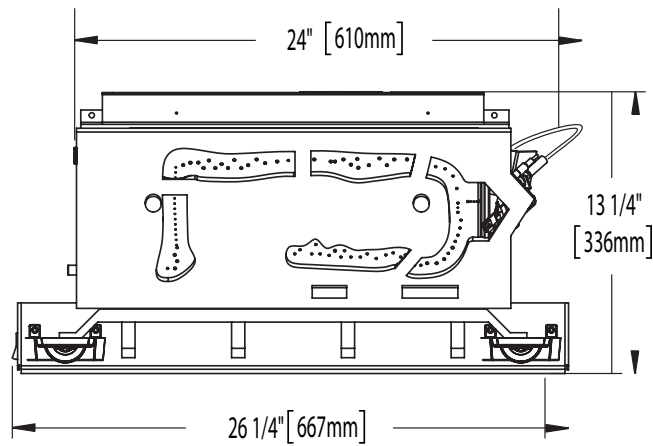

GVFL30

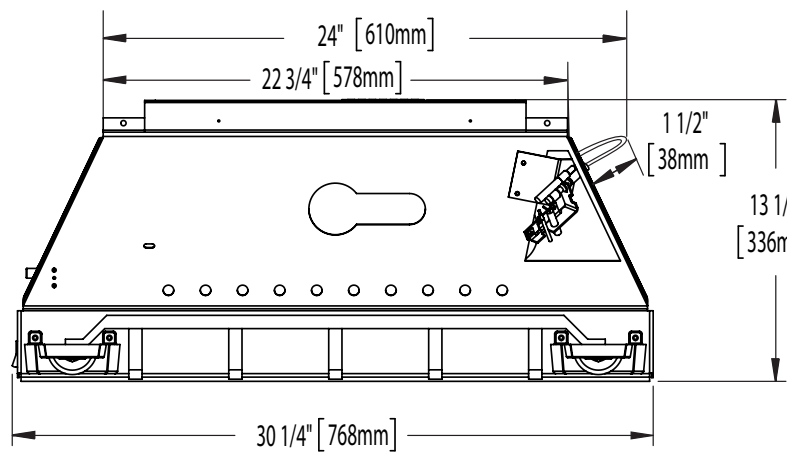

3.1 installation in an unvented application

WARNING

- Barriers such as the bottom of a glass door frame placed in front of a gas log set can change the air flow characteristics of the appliance which in turn can cause the appliance to carbon or overheat and malfunction.

During manufacturing, fabricating and shipping various components of this appliance are treated with certain oils, films or bonding agents.

These materials may produce smoke and smells as they are burned off during the initial operation of the appliance; possibly causing headaches or eye or lung irritation. This is a normal and temporary occurrence. Simply open a window to ventilate the room during the burn off period.

3.1.1 combustion and ventilation air provisions

This appliance shall not be installed in a confined space or unusually tight construction unless provisions are provided for adequate combustion and ventilation air.

The National Fuel Gas Code, ANSI Z223.1 / NFPA 54 defines a confined space as a space whose volume is less than 50 cubic feet per 1,000 Btu per hour (4.8 m³ per kw) of the aggregate input rating of all appliances installed in that space and an unconfined space as a space whose volume is not less than 50 cubic feet per 1,000 Btu per hour (4.8 m³ per kw) of the aggregate input rating of all appliances installed in that space. Rooms communicating directly with the space in which the appliances are installed, through openings not furnished with doors are considered a part of the unconfined space.

The GVFL 18/24/30 are all rated at 40,000 BTUs per hour and therefore requires a minimum unconfined space of 2,000 cubic feet.

3.1.2 determining confined or unconfined space

To determine the volume of the room where the appliance is to be installed, multiply the width x the length x the ceiling height of that room measured in feet. If any adjoining rooms are connected by grilles or openings such as kitchen pass-throughs, etc., the volume of those rooms may be added to the total.

Multiply the room volume by 1000 and divide this amount by 50 to determine the maximum BTU/hr that the space can support with adequate combustion and ventilation air.

Add the Btu/hr of all fuel burning appliances located within the space such as gas furnace, gas water appliance, etc. Do not include direct vent gas appliances which draw their input air from the outdoors and expel their exhaust to the outdoors.

WARNING

- If the area in which the appliance may be operated is smaller than that defined as an unconfined space or if the building is of unusually tight construction, provide adequate combustion and ventilation air by one of the methods described in the National Fuel Gas Code ANSI Z223.1 / NFPA 54, air for combustion and ventilation, or the applicable local code.
- If the area in which the appliance may be operated does not meet the required volume for indoor combustion air, combustion and ventilation air shall be provided by one of the methods described in the ANSI Z223.1 / NFPA 54, the International Fuel Gas Code, or applicable local codes.

Unusually tight construction is defined as construction where:

- Walls and ceilings exposed to the outside atmosphere have a continuous water vapour retarder with a rating of 1 perm (6 x 10⁻¹¹ kg per pa-sec-m²) or less with openings gasketed or sealed
- Weather stripping has been added on openable windows and doors
- Caulking or sealants are applied to areas such as joints around window and door frames, between sole plates and floors, between wall-ceiling joints, between wall panels, at penetrations for plumbing, electrical, and gas lines, and at other openings.

An unvented room appliance is recommended for use as a secondary heat source rather than as a primary source. Gas combustion produces water vapour which could occur at the rate of approximately one ounce of water for every 1,000 BTU/hr of gas input. During the cold weather season, indoor humidity levels tend to be low. Consequently, this water vapour can enhance the living space. However if a problem should occur:

- Ensure sufficient combustion and circulation air
- Use a dehumidifier
- Do not use the unvented room appliance as a primary heat source. Without sufficient fresh air for proper operation, poor fuel combustion can result. Carbon Monoxide is a result of poor fuel combustion.

If additional fresh air is required, use one of the methods described in the National Fuel Gas Code, ANSI Z223.1 / NFPA54 or the applicable local code.

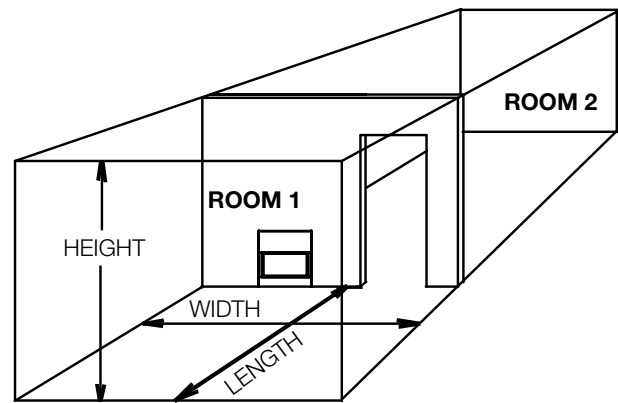

Room Volume = Length x Width x Height
 Max BTU/hr = Room Volume x 1000 / 50

If for example:

The length of the rooms is 5 feet (1.5m),
 The width of Room 1 is 10 feet (3.1m),
 The width of Room 2 is 15 feet (4.6m),
 The height of the rooms is 8 feet (2.4m).

Volume of Room 1: $5 \times 10 \times 8 = 400$ cubic feet (11.16 cubic meters)

Volume of Room 2: $5 \times 15 \times 8 = 600$ cubic feet (16.56 cubic meters)

EXAMPLE 1:

In this example, because there is no door to the adjoining room, the volume of the adjoining room may be added to the volume of the room with the heater to get a total unconfined space.

The total unconfined space: 400 ft^3 (11.3m³) + 600 ft^3 (17m³) = 1000 cubic feet (28.3m³).

Maximum BTU/h: $[(1000 \times 1000) \div 50] = 20,000$ BTU/h

If there are no more fuel burning appliances within this space then the 40,000 BTU/h input of the appliance is suitable to be installed. This also assumes that the construction of this space is not unusually tight.

EXAMPLE 2:

If in this example a solid door separates Room 1 from Room 2, the volume of Room 2 could not be used. In this case the maximum BTU/h would be:

Maximum BTU/h: $[(400 \times 1000) \div 50] = 8,000$ BTU/h

This would be considered a confined space since it can not support the 40,000 BTU/h input of the appliance and it would be necessary to provide adequate combustion and ventilation air to Room 1.

3.2 installing in a vented application

The appliance and gas logs function as a system. If the appliance is not drafting properly and spilling into the room (check with a match or a smoke stick), reposition the damper clamp until a positive draft is obtained by opening the damper. If negative pressure in home prevents having a positive draft, consult an air quality specialist.

3.2.1 damper stop installation

WARNING

- Before installing in a solid fuel burning fireplace, the chimney and firebox must be cleaned of soot, creosote, ashes and loose paint by a qualified chimney cleaner.

The damper must be permanently locked in position to prevent full closure and to provide a minimum flue opening. Various methods for locking the damper may be used but may be restricted from region to region and it is important to know the specifics that apply to your area. For your convenience a damper stop is provided with the appliance and may be used where not prohibited by state or local codes.

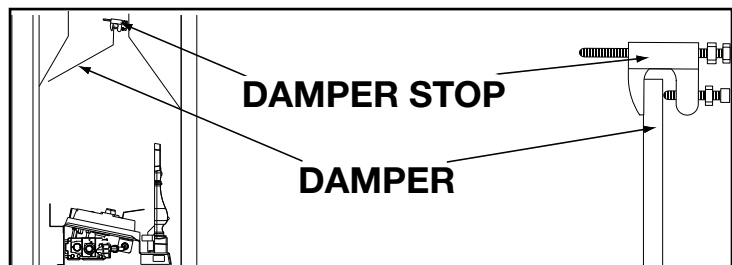

Use the 3" adjustable bolt to adjust the damper to the correct opening, based on the enclosed chart.

Should the damper stop not fit, or provide the required permanent opening from the Minimum Damper Opening table, have the damper cut to provide a minimum permanent opening or install an alternate stop.

Any outside air ducts and/or ash dumps in the appliance shall be permanently closed at time of appliance installation.

MINIMUM DAMPER OPENING (SQUARE INCHES)		
CHIMNEY HEIGHT	MASONRY APPLIANCE	FACTORY BUILT APPLIANCE
6	33.8"	
8	31.2"	
10	28.7"	22.1"
15	26.1"	17.3"
20	23.7"	14.5"
25	22.7"	12.6"
30	21.6"	11.3"
35		10.8"
40		10.2"

3.3 gas piping

WARNING

- Do not connect either the wall switch, thermostat or gas valve to electricity (110 volts).

This appliance and its appliance main valve must be disconnected from the gas supply piping system during any pressure testing of that system at test pressures in excess of 1/2 PSI (3.5kPa)

This appliance must be isolated from the gas supply piping system by closing the individual manual shut off valve during any pressure testing of the gas supply piping system at test pressure equal to or less than 1/2 psi (3.5 kPa)

- Centre the appliance in the appliance opening, making sure the appliance has enough room behind it for the gas line to run behind the log set under the log support.
- Route the gas line and sizing using piping 1/2" diameter or greater to allow the full volume of gas to the appliance. The routing of the gas line has to be done to local and / or national codes.
- When rigid pipe is used an ANSI approved manual shut off and a union must be installed upstream within the appliance cavity.
- To ensure the appliance operates reliably install a sediment trap upstream of the appliance within the structures of the piping system.
- When using propane, a regulator must be used between the tank and the outside wall of the house to ensure the line pressure does not exceed 14" w.c.
- Check gas connections with a gas detection device to test for leaks in the system. Soapy water mixture can also be used to check for leaks.
- Once all the gas connections are tested for leaks, start the appliance. Follow the lighting instructions to ensure the appliance is working properly before finishing.

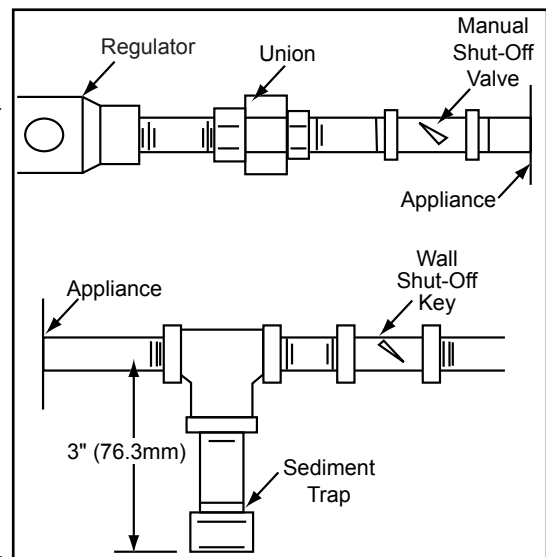

4.0 finishing

4.1 andiron and grate assembly

- A. With the 2 andirons laying face down, secure the grate overtop using 2x 1/4-20 bolts (supplied in the manual baggie).
- B. Install the grate/andiron assembly to the burner base using 4x 3/4" self tapping screws (supplied in the manual baggie).

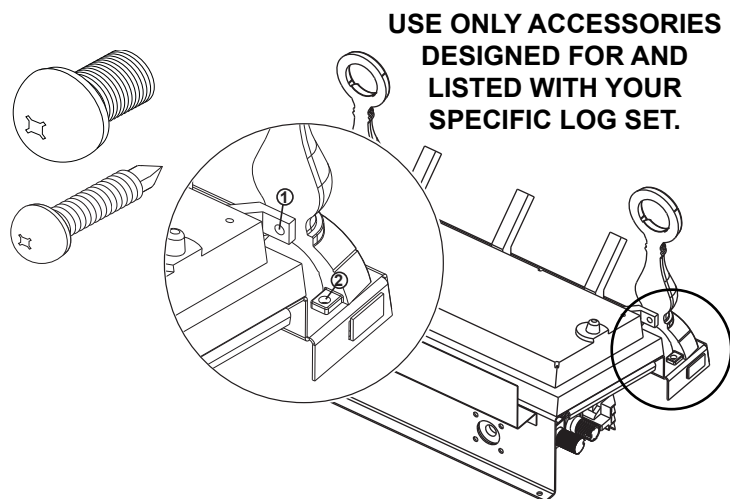

4.2 log placement

! WARNING

- Failure to position these logs in accordance with these diagrams or failure to use parts specifically approved with this appliance may result in property damage or personal injury.
- Do not place glowing embers, charcoal embers, vermiculite or charcoal lumps on this burner.

Phazer™ logs, exclusive to Napoleon, provide a unique and realistic glowing effect that is different in every installation. These logs are fuel specific. Do not interchange. Refer to the replacement parts list. Failure to follow these log placement instructions may cause sooting.

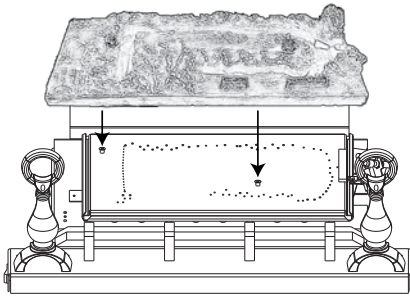

A. Place the fibre burner cover onto the two locating studs screwed into the pan burner.

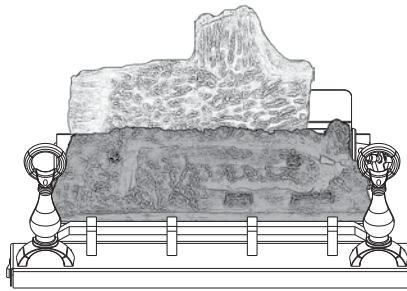

B. Place the rear log #1 onto the locating studs on the rear log support.

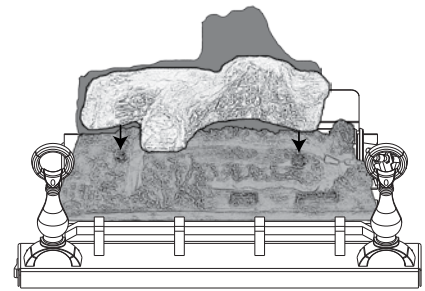

C. Position the holes on the bottom of log #2 onto the fibre embosses shown.

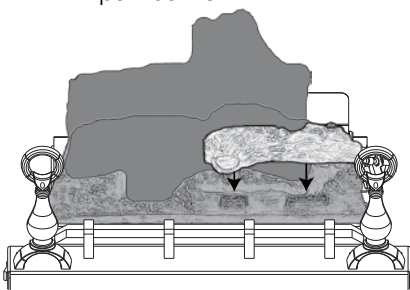

D. Position the slotted cavities on the bottom of log #6 onto the slotted projections shown. The charred face should be facing in.

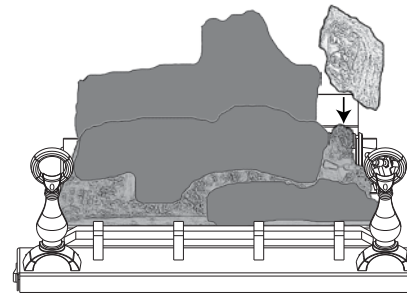

E. Position the bottom cavity of log #3 onto the bridge (top right corner of fibre burner cover) as shown, with the charred face inward.

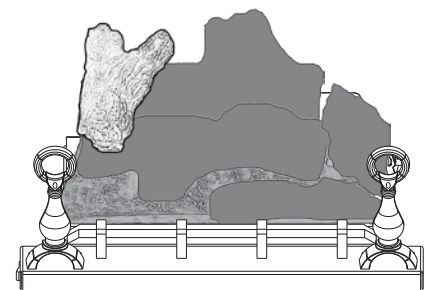

F. Position the pins on the bottom of log #4 into the holes on the left end of log #1 and the left end of log #2.

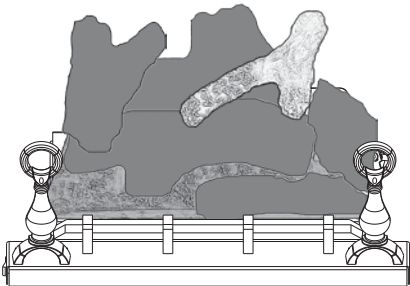

G. Place the end of log #5 on the right end of log #1. The fork in the log should straddle the knot on top of the log #2.

Log colours may vary. During the initial use of the appliance, the colours will become more uniform as colour pigments burn in during the heat activated curing process.

Positioning the logs improperly will cause flame impingement and carboning.

Blocked burner ports can cause an incorrect flame pattern, carbon deposits and delayed ignition. Phazer™ logs glow when exposed to direct flame. Use only certified Phazer™ logs available from your authorized dealer/distributor.

4.3 logo placement

Remove the backing of the logo supplied. Centre the logo on the front of the appliance, $\frac{1}{2}$ " in from the left side, as shown.

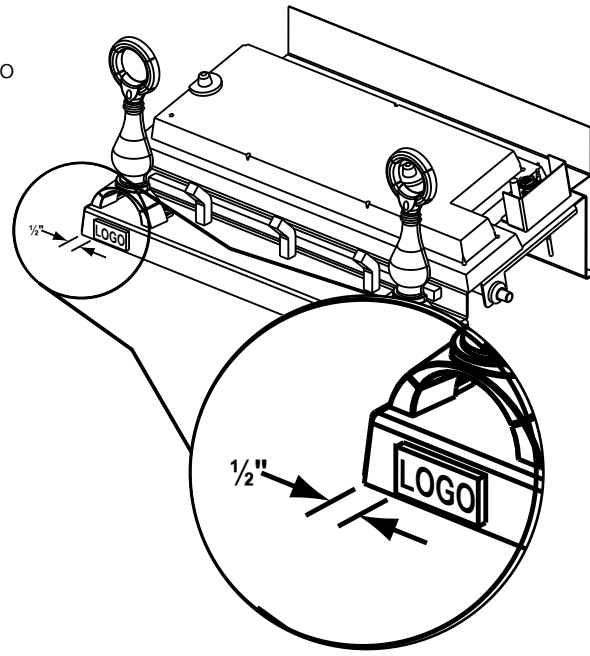

4.4 media

! WARNING

- All previously applied loose material must be removed prior to reapplication

- Place lava or ember rock around the base of the appliance, making sure not to block any burner ports or valve access. Retain a small amount of lava rock for step 3 and if applicable step 4.
- Place formed charcoal lumps around the front and sides of the appliance.
- Use remaining lava or ember rock to blend with the charcoal lumps.
- GVFL30 ONLY:** Sprinkle remaining lava rock onto the outer fibre ember beds to hide the seam.

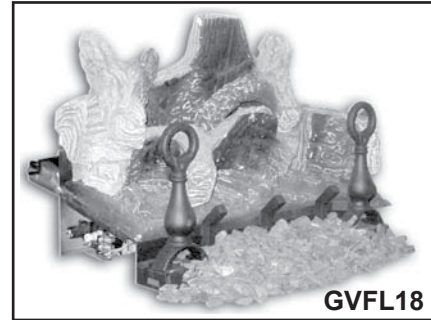

If the appliance is equipped with decorative glass doors, they must be fully opened when operating this gas log set.

5.1 lighting instructions

- A. Locate the pilot burner at the rear of the log set on the right side.
- B. Turn the gas control knob to the pilot setting (on the left side of the appliance closest to the back).
- C. With the control knob depressed, push the piezo igniter continuously until the pilot lights. Hold the control knob in for 1 minute and release. If the pilot goes out, repeat steps B and C.
- D. Once the pilot stays burning, make certain that the on / off switch is in the off position. Turn the control knob counter-clockwise to the on position.
- E. Turn the on / off switch to the on position to ignite the burner. This appliance must be isolated from the gas supply piping system by closing the individual manual shut off valve during any pressure testing of the gas supply piping system at test pressure equal to or less than 1/2 psi (3.5 kPa).

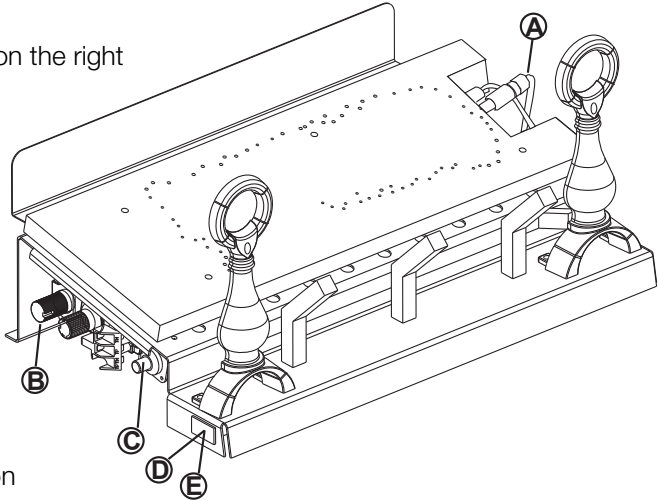

If appliance shuts off, do not relight until you provide fresh air. If appliance keeps shutting off, have it serviced. Keep burner and control compartment clean.

When lit for the first time, the appliance will emit a slight odour for a few hours. This is a normal temporary condition caused by the curing of the logs and the “burn-off” of internal paints and lubricants used in the manufacturing process and will not occur again. Open a window to ventilate the room during this burn off period.

5.2 match lighting instructions

- A. Remove any items necessary for easy access to the ODS (for example: logs, screens, etc.).
- B. Follow appropriate lighting instructions found previously. Instead of pushing and releasing the piezo button, light a match and hold the flame to the end of the pilot and ignite the pilot.
- C. After control knob has been released and pilot stays lit, reinstall any items that were removed for pilot access.
- D. Call a qualified service technician for repair or replacement of the piezo ignitor.

After extended periods of non-operation such as following a vacation or a warm weather season, the appliance may emit a slight odour for a few hours. This is caused by dust particles burning off. In both cases, open a window to sufficiently ventilate the room.

Purge the gas line with the glass door open. Assure that a continuous gas flow is at the burner before closing the door.

6.0 operation

WARNING

- If you do not follow these instructions exactly, a fire or explosion may result causing property damage, personal injury, or loss of life.
- If applicable, always light the pilot whether for the first time or if the gas supply has run out with the glass door opened or removed.

Ensure that a continuous gas flow is at the burner before installing the door. When lit for the first time, the appliance will emit an odor for a few hours. This is a normal temporary condition caused by the “burn-in” of paints and lubricants used in the manufacturing process and will not occur again. After extended periods of non-operation such as following a vacation or a warm weather season, the appliance may emit a slight odor for a few hours. This is caused by dust particles in the heat exchanger burning off. In both cases, open a window to sufficiently ventilate the room.

For vent free appliances ONLY: if the appliance shuts off, do not relight until you provide fresh air. If appliance keeps shutting off, have it serviced. Keep burner and control compartment clean.

FOR YOUR SAFETY READ BEFORE LIGHTING

- Do not turn on if children or other at risk individuals are near the appliance.
- This appliance is equipped with a pilot which must be lit by hand while following these instructions exactly.
- Before operating, smell all around the appliance area for gas and next to the floor because some gas is heavier than air and will settle on the floor.
- Use only your hand to turn the gas control knob. Never use tools. If the knob will not turn by hand, do not try to repair it. Call a qualified service technician. Force or attempted repair may result in a fire or explosion.
- Do not use this appliance if any part has been under water. Immediately call a qualified service technician to inspect the appliance and replace any part of the control system and any gas control which has been underwater.





WHAT TO DO IF YOU SMELL GAS

- Turn off all gas to the appliance.
- Open windows.
- Do not try to light any appliance.
- Do not touch any electric switch; do not use any phone in your building
- Immediately call your gas supplier from a neighbour's phone. Follow the gas supplier's instructions.
- If you cannot reach your gas supplier, call the fire department.

LIGHTING INSTRUCTIONS

note:

When lighting and re-lighting, the gas knob cannot be turned from pilot to off unless the knob is depressed.

- Stop! Read the above safety information on this label.
- Remove batteries from the transmitter and set thermostat to lowest setting, if equipped.
- Turn off all electrical power to the appliance.
- Open the glass door, if equipped.
- Turn the gas knob clockwise  to the “OFF” position.
- Wait five (5) minutes to clear out any gas. If you smell gas including near the floor, STOP! Follow the instructions above in the “WHAT TO DO IF YOU SMELL GAS” section. If you don't smell gas; close the glass door and go to the next step.
- If the appliance is equipped with flame adjustment valve turn clockwise  to “OFF”.
- Turn gas knob counter-clockwise  to the “PILOT” position. (If the appliance is equipped with an “ON/OFF” switch, ensure it is in the “ON” position.)
- Depress and hold gas knob while lighting the pilot with the push button ignitor. Keep knob fully depressed for one minute, then release. If pilot does not continue to burn, repeat steps E through I.
- With pilot lit, turn gas knob counter-clockwise  to the “ON” position.
- If equipped with the flame adjustment valve, push and turn the knob to high.
- Turn on all electrical power to the appliance and re-install the batteries into the transmitter, if equipped. Set thermostat to desired setting, if equipped.

GAS KNOB



TO TURN OFF GAS

- Set thermostat to desired setting, if equipped.
- Turn off all electrical power to the appliance if service is to be performed.
- Push in gas knob slightly and turn clockwise  to the “OFF” position. Do not force.

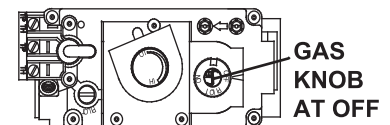

GAS KNOB AT OFF

7.1 air shutter

! WARNING

- Carbon can be distributed in surrounding living areas if the air shutter is improperly adjusted.
- Failure to keep the primary air opening(s) of the burner(s) clean may result in sooting and property damage.

LOG SET		AIR SHUTTER	
FUEL	NG	P	
GVFL18	9/32"	7/16"	
GVFL24	9/32"	7/16"	
GVFL30	9/32"	7/16"	

The air shutter settings are factory set for most installations. However, adjustment may be required depending on fuel type, vent performance and altitude.

Closing the air shutter will cause a more yellow flame, but can lead to carboning. Opening the air shutter will cause a more blue flame, but can cause flame lifting from the burner ports. The flame may not appear yellow immediately; allow 15 to 30 minutes for the final flame colour to be established.

7.2 flame characteristics

It's important to periodically perform a visual check of the pilot and burner flames. Compare them to the illustration provided. If any flames appear abnormal, call a service person.

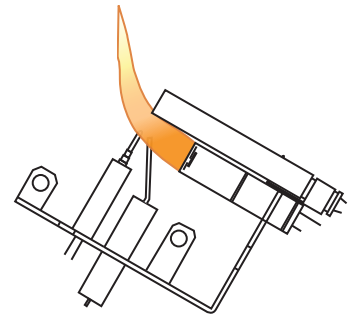
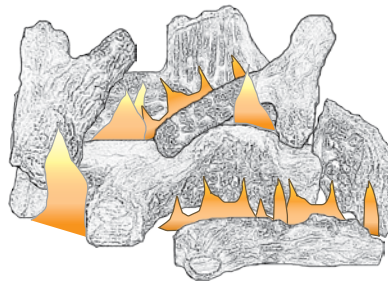

7.3 flame height adjustment

The adjustment is made by turning the Hi/Lo knob. The "Hi" setting corresponds to the maximum pressure to the burner and "Lo" corresponds to the minimum pressure. Actuation of this knob is independent from the actuation of the ON/OFF control.

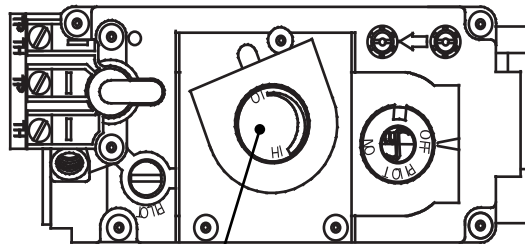

Hi / Lo Knob

8.0 maintenance

WARNING

- Turn off the gas and electrical power before servicing the appliance.

TURN OFF THE GAS AND ELECTRICAL POWER BEFORE SERVICING THE APPLIANCE.

Visually inspect the appliance for carbon buildup.

Using a small whisk or brush, brush off the excess carbon and vacuum up or sweep into the garbage.

Check the appliance for broken logs and corrosion of the main burner base.

8.1 oxygen depletion sensor (ODS) cleaning

This procedure must be performed by a qualified service person!

Inspect the pilot for any visible contamination or debris (usually lint, pet hair, spider webs, carpet fibre, etc.) and remove.

Disconnect the pilot from the pilot tubing line, using the appropriate wrench. Blow out the housing in the same direction as the gas flow. Re-install the pilot tube, turn on the gas and check for leaks.

If this does not improve the performance, replace the ODS with an exact replacement. The device is tamper resistant with no field serviceable parts.

CORRECT PILOT FLAME

Flame contacts thermocouple correctly (clean, stable and pronounced blue flame).

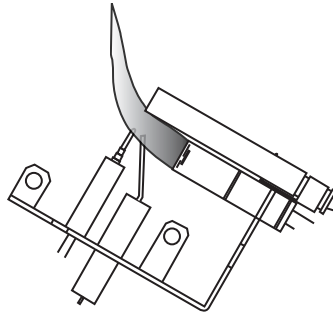

INCORRECT PILOT FLAME

Flame lifts off thermocouple (flame becomes unstable with more of an orange tip).

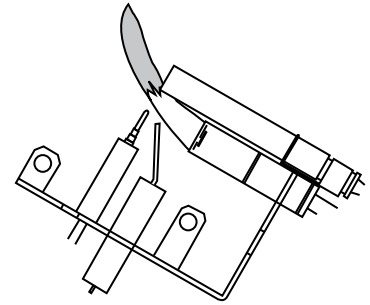

! WARNING

- Failure to position the parts in accordance with this manual or failure to use only parts specifically approved with this appliance may result in property damage or personal injury.

Contact your dealer for questions concerning prices and policies on replacement parts. Normally, all parts can be ordered through your Authorized dealer / distributor.

For warranty replacement parts, a photocopy of the original invoice will be required to honour the claim.

When ordering replacement parts always give the following information:

- Model & Serial Number of appliance
- Installation date of appliance
- Part number
- Description of part
- Finish

Parts, part numbers, and availability are subject to change without notice.

Parts identified as stocked will be delivered within 2 to 5 business days for most delivery destinations.

Parts not identified as stocked will be delivered within a 2 to 4 week period, for most cases.

Parts identified as 'SO' are special order and can take up to 90 days for delivery.

COMPONENTS		
REF NO.	PART NO.	DESCRIPTION
1	W135-0205	#1 - REAR LOG
2	W135-0206	#2 - MIDDLE LOG
3	W135-0413	#6 - FRONT LOG
4	W135-0207	#3 - RIGHT LOG
5	W135-0208	#4 - LEFT CROSSOVER LOG
6	W135-0218	#5 - RIGHT CROSSOVER LOG
7	GL-671	LOG SET
8	W185-0024	GVFL18 GRATE
8	W185-0020	GVFL24 GRATE
8	W185-0023	GVFL30 GRATE
9	W715-0628	GVFL18 / 24 ANDIRONS
9	W715-0629	GVFL30 ANDIRONS
10	W357-0001	PIEZO IGNITOR AND NUT
11	W456-0032	#32 ORIFICE - NG
11	W456-0050	#50 ORIFICE - LP
12	W660-0023	ON / OFF SWITCH
13	W725-0030	VALVE - NG
13	W725-0031	VALVE - LP
14*	W385-0334	NAPOLEON LOGO
15	W662-0003	NATURAL GAS - OXYGEN DEPLETION SENSOR
15	W662-0004	PROPANE GAS - OXYGEN DEPLETION SENSOR
16	W135-0394	FIBRE BURNER COVER
17	W010-2120	WELDED BURNER ASSEMBLY
18*	W550-0006	LAVA ROCK
19*	W550-0002	CHARCOAL LUMPS
20	W010-1288	DAMPER STOP
21*	W750-0060	IGNITOR CABLE
22*	W720-0093	PILOT TUBE
23*	W135-0265	GVFL30 RIGHT EXTENSION LOG
24*	W135-0266	GVFL30 LEFT EXTENSION LOG

ACCESSORIES

REF NO.	PART NO.	DESCRIPTION
25*	GD-660	REMOTE WALL SWITCH W/20" WIRE
26*	W660-0026	PROGRAMMABLE TIMER
27*	W550-0006	ADDITIONAL LAVA ROCK / CINDERS

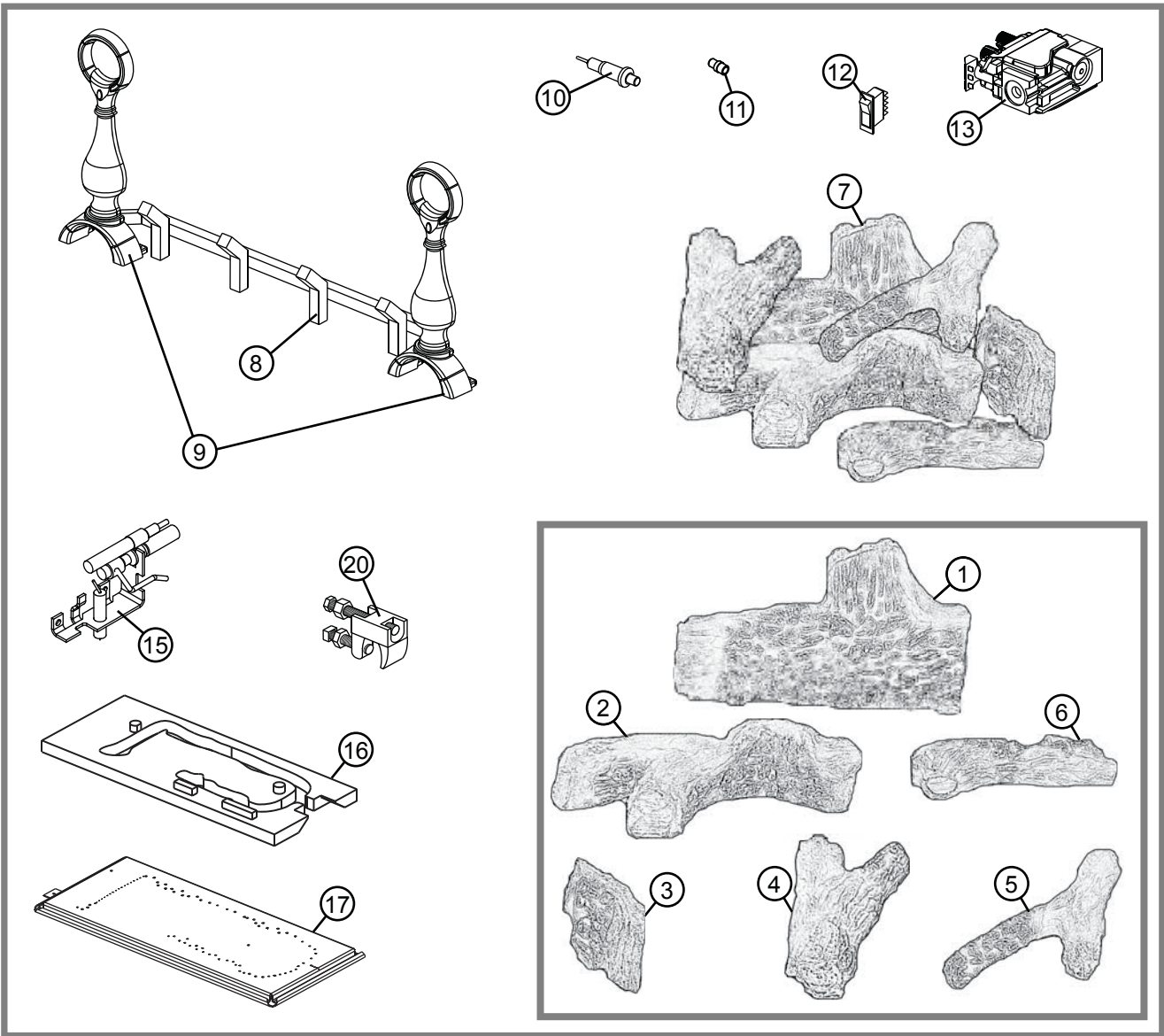

11.0 troubleshooting

! WARNING

- Always light the pilot whether for the first time or if the gas supply has run out with the glass door open or removed.
- Turn off the appliance completely and let cool before servicing. Only a qualified service person should service and repair this electric appliance.
- Appliance may be hot, do not service until appliance has cooled.
- Do not use abrasive cleaners.

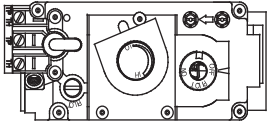
symptom	problem	test solution															
Flames are consistently too large or too small. Carboning occurs.	Appliance is over-fired or underfired.	<ul style="list-style-type: none"> - Check pressure readings: Inlet pressure can be checked by turning screw (A) counter-clockwise 2 or 3 turns and then placing pressure gauge tubing over the test point. Gauge should read as described on the chart below. Check that main burner is operating on 'HI'. Outlet pressure can be checked the same as above using screw (B). Gauge should read as described on the chart below. Check that main burner is operating on 'HI'. AFTER TAKING PRESSURE READINGS, BE SURE TO TURN SCREWS CLOCKWISE FIRMLY TO RESEAL. DO NOT OVER TORQUE. Leak test with a soap and water solution. 															
	 <p>* Maximum inlet pressure not to exceed 13"</p>	<table border="1"> <thead> <tr> <th>Pressure</th> <th>Natural Gas (inches)</th> <th>Natural Gas (millibars)</th> <th>Propane (inches)</th> <th>Propane (millibars)</th> </tr> </thead> <tbody> <tr> <td>Inlet</td> <td>* 7" (MIN. 4.5")</td> <td>17.4mb (MIN. 11.2mb)</td> <td>13" (MIN. 11")</td> <td>32.4mb (MIN. 27.4mb)</td> </tr> <tr> <td>Outlet</td> <td>3.5"</td> <td>8.7mb</td> <td>10"</td> <td>24.9mb</td> </tr> </tbody> </table>	Pressure	Natural Gas (inches)	Natural Gas (millibars)	Propane (inches)	Propane (millibars)	Inlet	* 7" (MIN. 4.5")	17.4mb (MIN. 11.2mb)	13" (MIN. 11")	32.4mb (MIN. 27.4mb)	Outlet	3.5"	8.7mb	10"	24.9mb
Pressure	Natural Gas (inches)	Natural Gas (millibars)	Propane (inches)	Propane (millibars)													
Inlet	* 7" (MIN. 4.5")	17.4mb (MIN. 11.2mb)	13" (MIN. 11")	32.4mb (MIN. 27.4mb)													
Outlet	3.5"	8.7mb	10"	24.9mb													
	Air shutter improperly adjusted.	<ul style="list-style-type: none"> - Return air shutter to specified opening, see "venturi adjustment" section. 															
Carbon is being deposited on glass, logs, rocks, media or combustion chamber.	<p>Air shutter has become blocked.</p> <p>Flame is impinging on the glass, logs, rocks, media or combustion chamber.</p>	<ul style="list-style-type: none"> - Ensure air shutter opening is free of lint or other obstructions. - Check that the logs are correctly positioned. - Check for ceiling or oscillating fans that may be influencing the flame. - Open air shutter to increase the primary air. See "venturi adjustment" section. - Check the input rate: check the manifold pressure and orifice size as specified by the rating plate. 															
Exhaust fumes smelled in room, headaches.	<p>Not enough combustion air.</p> <p>Not enough ventilation air.</p> <p>Flame is impinging on the logs or combustion chamber.</p>	<ul style="list-style-type: none"> - Increase fresh air supply. (Use one of the methods described in ANSI Z223.1 / NFPA 54 or the applicable local code.) - Increase fresh air supply. (Use one of the methods described in ANSI Z223.1 / NFPA 54 or the applicable local code.) - Check that the logs are correctly positioned. - Open air shutter to increase the primary air. See "venturi adjustment" section. - Check the input rate: check the manifold pressure and orifice size as specified by the rating plate values. 															
Main burner will not light; or is slow to light, noisy pilot.	<p>Inlet pressure too high.</p> <p>Pilot flame blowing off, missing thermopile.</p>	<ul style="list-style-type: none"> - Adjust inlet pressure to ensure 7.0" W.C. (17.4mb) at gas valve for natural gas and 13.0" W.C. (32.4mb) for propane. 															
Pilot is not functioning properly.	Pilot has been painted	<ul style="list-style-type: none"> - Using a piece of sandpaper or emery cloth remove the paint from the pilot hood, ignitor and flame sensor. 															
Pilot goes out while standing; Main burner is in 'OFF' position.	Gas piping is undersized.	<ul style="list-style-type: none"> - Turn on all gas appliances and see if pilot flame flutters, diminishes or extinguishes, especially when main burner ignites. Monitor appliance supply working pressure. - Check if supply piping size is to code. - Correct all undersized piping. 															
	Pilot flame is not large enough.	<ul style="list-style-type: none"> - ODS Burner requires checking. 															

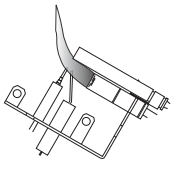
symptom	problem	test solution
Pilot will not light. 	Out of propane gas.	- Fill the tank.
	No spark at pilot burner.	- Check if pilot can be lit by a match. - Check that the wire is connected to the push button ignitor. - Check if the push button ignitor needs tightening. - Replace the wire if the wire insulation is broken or frayed. - Replace the electrode if the ceramic insulator is cracked or broken. - Replace the push button ignitor.
	No gas at the pilot burner.	- Check that the manual valve is turned on. - Check the pilot orifice for blockage. - Replace the valve / Oxygen Depletion Sensor System. - Call the gas distributor.
Pilot burning; no gas to main burner; gas knob is on 'HI'; wall switch / thermostat is on.	Thermostat or switch is defective.	- Connect a jumper wire across the wall switch terminals; if main burner lights, replace switch / thermostat.
	Wall switch wiring is defective.	- Disconnect wires from valve. Connect a jumper wire across terminals 1 & 3; if the main burner lights, check the wires for defects and / or replace wires.
	Main burner orifice is plugged.	- Remove stoppage in orifice.
	Faulty valve.	- Replace.
Pilot goes out when the gas knob is released. The gas valve has an interlock device which will not allow the pilot burner to be lit until the thermocouple has cooled. Allow approximately 60 seconds for the thermocouple to cool.	System is not correctly purged.	- Purge the gas line.
	Out of propane gas.	- Fill the tank.
	Pilot flame is not large enough. (Supply pressure too low.)	- Service or replace Oxygen Depletion Sensor System. - Correct piping and / or regulator to provide correct pressure. - Ensure adequate supply pressure.
	Thermocouple shorting / faulty.	- Loosen and tighten thermocouple. - Clean thermocouple and valve connection. - Replace Oxygen Depletion Sensor System. - Test and replace valve.
	Faulty valve / high low knob does not depress smoothly.	- Replace.
Main burner goes out; pilot stays on.	Pilot flame is not large enough or not engulfing the thermopile.	- Ensure adequate supply pressure. - Replace pilot assembly.
	Thermopile shorting / loose connection.	- Clean thermopile connection to the valve. Reconnect. - Replace thermopile / valve.
	Remote wall switch wire is too long; too much resistance in the system.	- Shorten wire to connect length or wire gauge.
	Faulty thermostat or switch.	- Replace.
Main burner goes out; pilot goes out.	Insufficient air supply.	- Open window or door. (Use one of the methods described in ANSI Z223.1 / NFPA54 or the applicable local code.) - Have room checked for adequate air exchange. - See "combustion and ventilation air provisions" section to ensure adequate air supply.
	Out of propane gas.	- Fill the tank.
	Pilot flame is not large enough. (Supply pressure too low.)	- Service or replace Oxygen Depletion Sensor System.
Remote wall switch is in "off" position; main burner comes on when gas knob is turned to "ON" position.	Wall switch mounted upsidedown.	- Reverse.
	Wall switch is grounding.	- Replace.
	Wall switch wire is grounding.	- Check for ground (short); repair ground or replace wire.
	Faulty valve.	- Replace.

12.0 warranty

Napoleon products are manufactured under the strict Standard of the world recognized ISO 9001 : 2015 Quality Management System.

Napoleon products are designed with superior components and materials assembled by trained craftsmen who take great pride in their work. The burner and valve assembly are leak and test-fired at a quality test station. The complete appliance is again thoroughly inspected by a qualified technician before packaging to ensure that you, the customer, receive the quality product that you expect from Napoleon.

Napoleon Gas Appliance President's Lifetime Limited Warranty

The following materials and workmanship in your new Napoleon gas appliance are warranted against defects for as long as you own the appliance. This covers: combustion chamber, heat exchanger, stainless / steel burner, Phazer™ logs and embers, rocks, ceramic glass (thermal breakage only), gold plated parts against tarnishing, porcelainized enameled components and aluminum extrusion trims.*

Electrical (110V and millivolt) components and wearable parts are covered and Napoleon will provide replacement parts free of charge during the first year of the limited warranty. This covers: blowers, gas valves, thermal switches, switches, wiring, remote controls, ignitors, gaskets and pilot assemblies.*

Labour related to warranty repair is covered free of charge during the first year (labour warranty is not applicable for the Gas Log Sets). Repair work, however, requires the prior approval of an authorized company official. Labour costs to the account of Napoleon are based on a predetermined rate schedule and any repair work must be done through an authorized Napoleon dealer.

* Construction of models vary. Warranty applies only to components included with your specific appliance.

Conditions and Limitations

Napoleon warrants its products against manufacturing defects to the original purchaser only. Registering your warranty is not necessary. Simply provide your proof of purchase along with the model and serial number to make a warranty claim. Napoleon reserves the right to have its representative inspect any product or part thereof prior to honouring any warranty claim. Provided that the purchase was made through an authorized Napoleon dealer your appliance is subject to the following conditions and limitations:

Warranty coverage begins on the date of original installation. This factory warranty is non-transferable and may not be extended whatsoever by any of our representatives. The gas appliance must be installed by a licensed, authorized service technician or contractor qualified and authorized installer, service agency or supplier. Installation must be done in accordance with the installation instructions included with the product and all local and national building and fire codes. This limited warranty does not cover damages caused by misuse, lack of maintenance, accident, alterations, abuse or neglect, and parts installed from other manufacturers will nullify this warranty. This limited warranty further does not cover any scratches, dents, corrosion or discoloring caused by excessive heat, abrasive and chemical cleaners nor chipping on porcelain enamel parts, mechanical breakage of Phazer™ logs and embers. This warranty extends to the repair or replacement of warranted parts which are defective in material or workmanship provided that the product has been operated in accordance with the operation instructions and under normal conditions. After the first year, with respect to this President's Lifetime Limited Warranty, Napoleon may, at its discretion, fully discharge all obligations with respect to this warranty by refunding to the original warranted purchaser the wholesale price of any warranted but defective part(s).

After the first year, Napoleon will not be responsible for installation, labour, or any other expenses related to the reinstallation of a warranted part and such expenses are not covered by this warranty. Notwithstanding any provisions contained in the President's Lifetime Limited Warranty, Napoleon's responsibility under this warranty is defined as above and it shall not in any event extend to any incidental, consequential or indirect damages. This warranty defines the obligations and liability of Napoleon with respect to the Napoleon gas appliance and any other warranties expressed or implied with respect to this product, its components or accessories are excluded. Napoleon neither assumes, nor authorizes any third party to assume, on its behalf, any other liabilities with respect to the sale of this product. Napoleon will not be responsible for: over-firing, downdrafts, spillage caused by environmental conditions such as rooftops, buildings, nearby trees, hills, mountains, inadequate vents or ventilation, excessive venting configurations, insufficient makeup air, or negative air pressures which may or may not be caused by mechanical systems such as exhaust fans, furnaces, clothes dryers, etc. Any damages to the appliance, combustion chamber, heat exchanger, plated trim or other components due to water, weather damage, long periods of dampness, condensation, damaging chemicals or cleaners will not be the responsibility of Napoleon.

During the first 10 years Napoleon will replace or repair the defective parts covered by the lifetime warranty at our discretion free of charge. From 10 years to life, Napoleon will provide replacement parts at 50% of the current retail price. The manufacturer may require that defective parts or products be returned or that digital pictures be provided to support the claim. Returned products are to be shipped prepaid to the manufacturer for investigation. If a product is found to be defective, the manufacturer will repair or replace such defect. Before shipping your appliance or defective components, your dealer must obtain an authorization number. Any merchandise shipped without authorization will be refused and returned to sender. Shipping costs are not covered under this warranty. Additional service fees may apply if you are seeking warranty service from a dealer. Warranty labour allowance is only for the replacement of the warranted part. Travel, diagnostic tests, shipping and other related charges are not covered by this warranty.

Appliance Service History This appliance must be serviced annually depending on usage.				
Date	Dealer Name	Service Technician Name	Service Performed	Special Concerns

Lined writing area consisting of 34 horizontal lines.

NAPOLEON CELEBRATING OVER 40 YEARS OF HOME COMFORT PRODUCTS



7200, Route Transcanadienne, Montréal, Québec H4T 1A3
24 Napoleon Road, Barrie, Ontario, Canada L4M 0G8
214 Bayview Drive, Barrie, Ontario, Canada L4N 4Y8
103 Miller Drive, Crittenden, Kentucky, USA 41030
De Riemsdijk 22, 4004 LC Tiel, The Netherlands

Phone: 1-866-820-8686
napoleon.com