

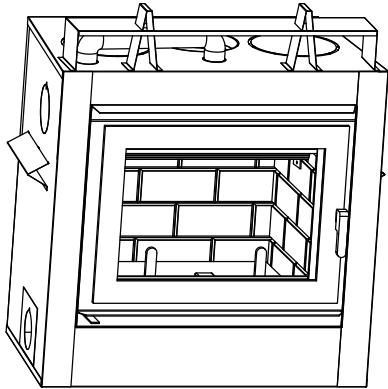

INSTALLATION AND OPERATION INSTRUCTIONS



WRT3820WS



**SAVE THESE INSTRUCTIONS
FOR FUTURE REFERENCE**

An French manual is available upon request. Order P/N 900084-00.

Ce manuel est disponible en français, simplement en faire la demande. Numéro de la pièce 900084-00.

	<p>! WARNING</p> <ul style="list-style-type: none">• Hot! Do not touch! The glass and surfaces of this appliance will be hot during operation and will retain heat for a while after shutting off the appliance. Severe burns may result.• Carefully supervise children in the same room as appliance.
	<ul style="list-style-type: none">• If small children are present in the home, it is recommended that this appliance be fitted with an adjustable safety gate or barrier screen.

EPA Wood-Burning Fireplace
P/N 900083-00 REV. B 03/2015

MODELS

WRT3820WS

This installation manual will enable you to obtain a safe, efficient and dependable installation of your fireplace system. Please read and understand these instructions before beginning your installation.

Do not alter or modify the fireplace or its components under any circumstances. Any modification or alteration of the fireplace system, including but not limited to the fireplace, chimney components and accessories, may void the warranty, listings and approvals of this system and could result in an unsafe and potentially dangerous installation.

IHP wood-burning fireplaces are designed for use as a supplemental heater. They are not intended for continuous use as a primary heat source.

! WARNING

- **The fireplace cannot be operated without a door or firescreen. Consult your dealer to select the correct replacement door or firescreen.**
- **The fireplace is equipped with a blower, electrical connection must be made prior to fireplace installation**
- **Important! To assure proper alignment of glass doors: Install this fireplace in a square and plumb condition, using shims as necessary at sides and/or bottom.**
- **Install the fireplace only as described in these instructions.**



Listed to standards:
ULC-S610 and UL-127
Report # 14-181
EPA Cert. No. 706

NATIONAL
FIREPLACE
INSTITUTE



CERTIFIED
www.nficertified.org

We recommend that our woodburning hearth products be installed and serviced by professionals who are certified in the U.S. by the National Fireplace Institute® (NFI) as NFI Woodburning Specialists or who are certified in Canada by Wood Energy Technical Training (WETT).



P900083-00

IMPORTANT! GENERAL SAFETY PRECAUTIONS. READ AND UNDERSTAND THESE SAFETY RULES BEFORE YOUR FIRST FIRE.

⚠ WARNING

THE FIREPLACE MUST BE OPERATED WITH THE DOORS FULLY OPENED OR DOORS FULLY CLOSED. IF THE DOORS ARE LEFT PARTLY OPENED, GAS AND FLAME MAY BE DRAWN OUT OF THE FIREPLACE OPENING, CREATING RISKS OF BOTH FIRE AND SMOKE. IF THE UNIT IS OPERATED WITH THE DOORS FULLY OPENED, THE FIRE SCREEN MUST BE USED.

⚠ WARNING

NEVER use gasoline, gasoline-type lantern fuel, kerosene, charcoal lighter fluid, naphtha, engine oil or similar liquids to start or "freshen up" a fire in this fireplace. Keep any flammable liquids a safe distance from the fireplace at all times.

⚠ WARNING

THIS FIREPLACE HAS NOT BEEN TESTED WITH AN UNVENTED GAS OR A FIREPLACE INSERT. TO REDUCE RISK OF FIRE OR INJURY, DO NOT INSTALL AN UNVENTED GAS LOG SET OR FIREPLACE INSERT OR OTHER PRODUCTS NOT SPECIFIED FOR USE WITH THIS FIREPLACE.

⚠ WARNING

Never leave children unattended when there is a fire burning in the fireplace.

⚠ WARNING

To avoid the risk of damaging fireplace materials and increasing the risk of fire, do not use the fireplace to cook or warm food.

⚠ WARNING

Use care when selecting window treatments for windows located near the fireplace. Avoid using combustible flowing window treatments such as curtains on nearby windows that are of sufficient length to be blown in front of an open flame when the window is opened.

Keep any combustible furniture, materials or decorative pillows at least 48" (1219 mm) from the front fireplace opening.

⚠ WARNING

Never leave your fireplace unattended while it is burning.

⚠ IMPORTANT

When burning wood, use SOLID NATURAL DRY WELL-SEASONED WOOD ONLY. Hardwoods are recommended (soft woods tend to burn very quickly).

- **DO NOT burn treated wood, charcoal, coal, trash, cardboard, driftwood, woods dipped in tar, Christmas tree greens, pitch, pine tar, creosote, chemical chimney cleaners, flame colorants, polystyrene packaging, wood products with synthetic binders (i.e. plywood). Plywood, lumber and other misc. materials can produce abnormally high temperatures, sputtering and smoking fires and may contain hazardous chemicals to treat insects and fungus.**
- **Burning unapproved fuels can produce excessive temperatures, beyond the design capabilities of the fireplace and may produce excess sparks or may contain hazardous chemicals. Burning unapproved fuels can result in a chimney fire, a house fire, personal injury, death or loss of property.**

⚠ WARNING

Be careful adding wood fuel to the fire or handling fireplace tools such as shovels, tongs or pokers.

⚠ WARNING

Never modify or alter your fireplace system in any way. To do so may create a potential fire hazard and void the limited warranty, listings and approvals of this system.

⚠ WARNING

The bottom refractory can be cracked by excessive abuse such as tossing heavy logs onto the grate or gouging with fireplace tools. Exercise caution when adding wood to your fireplace.

⚠ WARNING

Neither the manufacturer nor the seller warrants "smoke free" operation nor are we responsible for inadequate system draft caused by mechanical systems, general construction conditions, inadequate chimney heights, adverse wind conditions and/or unusual environmental factors or conditions beyond our control.

⚠ WARNING

Always ensure that the air inlet to the fireplace is free from debris and any other obstructions that can block the entrance of air.

LOCATING THE NAME PLATE

The name plate has been attached to a chain located inside the front opening below the door. To locate it, simply place your hand into the center of the opening and slide it to the right. Locate the chain and pull on it to access the name plate.

CONGRATULATIONS!

When you purchased your new fireplace, you joined the ranks of thousands of individuals whose answer to their home heating needs reflects their concern for aesthetics, efficiency and our environment. We extend our continued support to help you achieve the maximum benefit and enjoyment available from your new fireplace.

Thank you for selecting a IHP fireplace as the answer to your home supplemental heating needs.

TABLE OF CONTENTS

SAFETY RULES	Page 2
Locating the Name Plate	Page 2
Introduction	Page 3
Parts Required	Page 3
Optional Equipment.....	Page 3
Operating The WRT3820WS Fireplace	Page 3
Fuel	Page 3
Starting And Maintaining A Fire	Page 4
Combustion Control	Page 4
Refueling For Best Performance	Page 4
Smoking – Causes And Troubleshooting	Page 4
Important Cautions	Page 5
Maintaining Your WRT3820WS Fireplace	Page 5
Creosote.....	Page 5
Chimney Maintenance.....	Page 5
Dealing With A Chimney Fire.....	Page 5
Top Baffle Removal	Page 6
Finish Door Casing Care.....	Page 6
Disposing of Ashes	Page 7
Refractory Installation.....	Page 7
Door Removal	Page 7
Door Adjustment.....	Page 7
Glass Care - Replacement	Page 8
Glass Care - Cleaning	Page 8
Gasket Replacement	Page 8
Fireplace Installation	Page 8
Locating The WRT3820WS Fireplace	Page 8
Optional Cast Facade Installation	Page 9
Hearth Extension Requirements	Page 9
Framing, Facing And Mantel.....	Page 10
Fireplace Blower.....	Page 12
Hot Air Ducting Installation	Page 12
Gravity Kit	Page 12
Central Forced Air Kit	Page 13
Outside Air Kit	Page 14
Chimney System	Page 15
Chimney Installation Notes	Page 15
Chimney Installation Instructions.....	Page 16
Offset Chimney Installation	Page 17
Angled Wall Radiation Shield	Page 20
Chimney Support Installation.....	Page 20
Chimney Chase And Multiple Terminations.....	Page 20
Masonry Application Instructions	Page 21
Installation Accessories	Page 22
Replacement Parts	Page 23
Specifications.....	Page 23
Clearance to Combustibles	Page 23
Chimney Components Lists	Page 24
Warranty	Page 27
Product Reference Information	Page 28

THE FIREPLACE

INTRODUCTION

The WRT3820WS wood-burning fireplace is an energy efficient, heat circulating, closed combustion fireplace. You will receive a lifetime of comfort and enjoyment from your fireplace provided it is installed, maintained and operated properly.

- Please read these instructions and retain this manual for future reference.
- Before beginning the fireplace installation, consult the local authorities to obtain your building permit and check your local building codes. Install the fireplace only as described in these instructions and using only IHP components.
- This fireplace has been tested for CAN/ULC S610-M87 and ANSI/UL 127 under report number 3151759. It has also been tested for EPA 40 C.F.R Part 60, section 60.532(b). Certificate number 706.
- The WRT3820WS fireplace is NOT intended for use with a gas log set. Do not use a fireplace insert or any other product with this fireplace unless it is specified by IHP for use with this appliance. Failure to follow these instructions will void the certification and the warranty of the fireplace and may result in an unsafe installation.
- These appliances are designed to provide supplemental heat to the immediate area only. Therefore, it is advisable to have an alternate heat source when installed in a dwelling.
- These appliances are not approved for Manufactured Home installations.

PARTS REQUIRED

Fireplace Model WRT3820WS

- **6" diameter chimney*** - Model ASHT+, S-2100+, HT6000+, HT6103+ or AC manufactured by Security Chimneys International™ only.
OR
- **7" diameter chimney*** - Model ASHT and HT6103 manufactured by Security Chimneys International™ only.
6" and 7" Chimneys Includes:
 - Chimney lengths
 - Elbows (*where necessary*)
 - Associated components as per these installation instructions
- **Decorative Door** (included in the fireplace)
- **UZY6 blower** (Included w/Fireplace)
- **Outside Air Kit** (Included w/Fireplace)
(required if using AC Chimney)

OPTIONAL EQUIPMENT

Order Separately - See Pages 22 and 23

- **Additional Equipment (optional)**
 - AC Chimney Starter Section* and AC Chimney*
 - Outside Air Kit
(required if using AC Chimney)
 - Chimney Adaptor 7 inch (6AW7*)
(If you choose to use 7 inch ASHT* or HT6103* chimney)
 - Gravity Venting System
 - Rigid Firescreen
 - Forced Air Kit ①
 - Cast Facade Kit
 - Blower Speed Control (VRUW)
 - Blower Thermodisc Heat Switch Control (VTU)

① **Not tested under EPA certification. If installed, this appliance no longer qualifies for EPA certification.**

OPERATING THE WRT3820WS FIREPLACE

Fuel

USE SOLID NATURAL WOOD FUEL ONLY. The WRT3820WS fireplace is designed to work best when fueled with dry seasoned natural wood only. Hardwoods are preferred to softwoods since the energy content of wood is relative to its density. Hardwoods will result in a longer burning fire and less frequent refueling. A moisture content of 15% to 20% (seasoned) is recommended. Wood that has been cut and split and let to dry under a cover for a period of one year will usually meet that criteria. The required drying time will vary depending on the climate. Wood that is packed tight together will take longer to dry. Seasoned wood is darker in color than wet wood and will have visible cracks in the grain on the ends. Excessively wet wood will be difficult to burn and will result in lower efficiency, increased creosoting and deposits on the glass and in the chimney. Excessively dry wood will burn well but will also have higher emissions and shorter burning time.

Do not burn scrap or garbage, treated wood or wood such as driftwood from the ocean which has been exposed to salt or other chemicals. Salt or chemicals can corrode the firebox and chimney. Do not burn large amounts of paper, cardboard, Christmas tree branches or building construction materials. Intense firing with these materials may overheat the fireplace, causing damage to the unit, a fire or even possibly igniting a chimney fire if the chimney is creosoted. Burning unapproved fuel, resulting in excessive pollutants being emitted, may be prohibited and subject to a fine or other penalty by the authority having jurisdiction in your area.

Processed firelogs can be used. Use only firelogs that have been evaluated for the application of fireplace and refer to firelog warnings and caution markings on packaging prior to use.

First Fires

Before using the fireplace make sure to remove the plastic wrapping and EPA label on door. Remove any glue residue left by the label using mild soap.

The first five or six fires should be small fires of short duration (about 30 to 60 minutes). This will help cure the refractory bricks. During the first few fires of this appliance there may be some odor and smoke due to the curing of the paint, dust accumulation and burning off of lubricants used in the manufacturing process. It may set off a smoke alarm located in the same room. For this reason the room should be well ventilated for the first few fires.

Building a Fire (starting and maintaining a fire)

To start a fire, place several crumpled up balls of newspaper in the firebox. Place small dry pieces of the kindling on top of the paper, criss-crossing the kindling so that there are air spaces in between. Keep the fuel far back enough so that air can get underneath. Open the air controls fully and light the newspaper. Once the newspaper and the kindling is well ignited, close the door. Once the kindling fire is well established, cord wood can be added (see *Primary Air Combustion Control* section for proper operation of the air controls).

The unit will burn best with 1-2 pieces of cord wood spaced 1 to 2 inches apart and allowing air to get under the fuel. Criss-crossing or arranging the fuel so that air can get underneath, will help the fire to get started easily. The unit should be operated with the air control fully open long enough to get the cord wood well ignited.

COMBUSTION CONTROLS

Primary Air and Air Boost Controls

There is no flue damper in the WRT3820WS fireplace. As is common with air tight stoves, the combustion air control sets the flow of air entering the firebox. This allows for a more precise control of the fire. The combustion air control is located below the door on the left side. The main source of air (primary air) entering the firebox can be diminished by moving the

air combustion control from left to right. The primary air is fully opened when the air control is completely moved to the left. The air control device can also be used to add an extra boost of air especially during fire start up and reloading of the unit.

Pulling the air combustion control will induce an air boost at the base of the fire allowing an easier fire start up. When the fire is well established, the control can be pushed in to shut down the air boost allowing for a longer burn time. The combustion air control should be in the closed position (primary air and air boost) when the fireplace is not in use. This will minimize air leakage up the chimney. The combustion air control should be opened before opening the door to minimize the possibility of back draft coming into the room.

Accelerated Combustion

The maximum heat output for the WRT3820WS fireplace is achieved by burning with the door closed and the combustion air opened. By this method, the WRT3820WS fireplace can produce the maximum BTU of heat per hour. However, it will be necessary to reload with wood every one or two hours. This is the least efficient method of burning the WRT3820WS fireplace.

Use caution when firing with the combustion air control wide open. Only burn cord wood in this manner. Small dry pieces of softwood and construction scraps will burn very intensely using this method and may damage the firebox.

Medium Combustion

This is the recommended mode of operating the WRT3820WS fireplace and should be the one normally used since it will deposit the least amount of creosote on the glass and in the chimney. The combustion air control must be 3/4 closed and pushed in to close the air boost. The precise setting will depend on many factors, including chimney length and the moisture content of the wood.

For instance, a long chimney will necessitate closing the damper more. To obtain the proper combustion, close the damper completely, then open it about 1/4" to 1/2" (6.4mm to 13mm). Two medium size pieces of wood should be burning on a bed of hot coals. The heat output will be approximately 25,000 BTU per hour and the loading time will be about every 3-4 hours. Softwoods may be burned using this method but the time will be substantially reduced.

Slow Combustion

When the air combustion control is completely closed, the fireplace is in a slow combustion phase. If the hearth is hot enough, slow combustion will not extinguish the fire, but there will be a noticeable change in the flame pattern. The flames will be slow and may appear dirty if the wood is too wet (moisture content of 20% and more). Do not allow the wood to burn without flame, since this will produce excessive creosote in the unit.

Creosote may accumulate on the glass door. This method of burning should be used only after operating the WRT3820WS fireplace with the air control opened to produce a hot fire for about an hour or at medium pace for at least three (3) hours. Slow combustion can be used at night in order to reduce the heat output and to prolong the burn. The loading time will be between 6-8 hours.

REFUELING FOR BEST PERFORMANCE

The WRT3820WS fireplace will operate best if attention is given to operating the unit with the damper fully opened after refueling in order to bring the firebox and the chimney system up to their optimum operating temperature. Combustion efficiency is relative to firebox temperature. A temperature of 500° C (932° F) and up, with a visible flame, in the upper part of the firebox indicates a maximum efficiency. To obtain this temperature, the fireplace must be operated with the primary air and air boost controls fully opened during 10 to 20 minutes after reloading, depending on the heat and on the moisture content of the wood.

Once you have reached the desired temperature, the air boost can be closed and the primary air set to a medium setting. You know you have reached the desired temperature when, closing the primary air control, you can see a flame at the top of the firebox. The benefit of this technique will be cleaner glass, less creosoting, greater efficiency and the most pleasing fire for your enjoyment.

SMOKING – CAUSES AND TROUBLESHOOTING

To reduce the likelihood of smoking when opening the door, set the combustion air controls to the left before opening the door. Your fireplace has been designed and tested to provide smoke free operation. Occasionally, there may be a small amount of smoking upon lighting the fire, until the chimney heats up but this should not continue. If the fireplace continues to smoke it is probably for one of the following reasons:

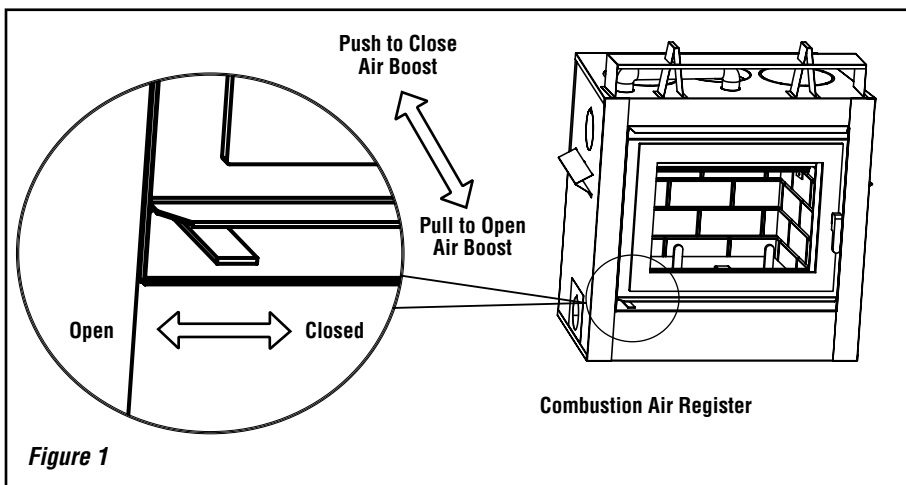

Figure 1

A. Negative pressure in the house

As the fire burns, air goes up the chimney. This air must be replaced through leakage into the house or through the outside air duct (optional). When operating the WRT3820WS fireplace, open a nearby window temporarily to check if there is adequate replacement air supply.

B. Fans operating (e.g.: range hood)

These fans draw air out of the house and may actually cause a negative pressure in the house. Turn off all fans and open a nearby window to determine if this is the cause of the problem.

C. Wet wood

Wet or tarred wood will smoulder and smoke instead of burning properly. Your dealer can help you determine if you have properly seasoned wood for burning.

D. Dirty or blocked chimney

Check to make sure the chimney is clear and clean. If dirty call a certified chimney sweep or use a properly sized chimney brush to clean.

E. Chimney not long enough

The minimum chimney height is twelve (12) feet (3.7 m) not including the fireplace height. The chimney must extend at least three (3) feet (915 mm) above its point of contact with the roof and at least two (2) feet (610 mm) higher than any roof or wall within ten (10) feet (3 m) of it. When installed with offsets, the minimum chimney height is fifteen (15) feet (4.6 m). Additional height will increase draft and will decrease the tendency to smoke.

F. Poor chimney draft

With no fire, there should be sufficient draft to exhaust cigarette smoke introduced under the baffle. Chimneys installed against an outside wall without protection or a basement installation may generate back draft problems which will cause start-up problems. To prevent this, open a nearby window, roll up a piece of paper and light it. Then, hold it in the upper part of the firebox to warm up the chimney. Wait until the draft is sufficient, then start the fire.

IMPORTANT CAUTIONS

- A. Do not block the hot air vents to the fireplace as this will cause the fireplace to overheat.
- B. Never use gasoline, gasoline-type lantern fuel, kerosene, charcoal lighter fluid, or similar liquids to start or 'freshen up' a fire in this fireplace. Keep all such liquids well away from the fireplace while it is in use.
- C. Do not burn coal. The sulphur in coal will corrode the firebox and chimney.
- D. Do not burn driftwood which has been in the ocean or salt water. The salt will corrode the firebox and chimney.
- E. Do not burn wood in the area in front of the grate.
- F. Do not abuse the unit by burning paper, or cardboard or construction material such as pressed wood, plywood or lumber.
- G. Do not allow the wood to smoulder or burn without flame, since this will produce excessive creosote in the unit as well as increased particulate emissions.

Smoke Detectors

Since there are always several potential sources of fire in any home, we recommend installing smoke detectors. If possible, install the smoke detector in a hallway adjacent to the room (to reduce the possibility of occasional false activation from the heat produced by these appliances). If your local code requires a smoke detector be installed within the same room, you must follow the requirements of your local code. Check with your local building department for requirements in your area.

Carbon Monoxide Monitor Recommended

Carbon Monoxide Poisoning: Early signs of carbon monoxide poisoning are similar to the flu with headaches, dizziness and/or nausea. If you have these signs, obtain fresh air immediately. Turn off the gas supply to the appliance and have it serviced by a qualified professional, as it may not be operating correctly. Some people are more affected by carbon monoxide than others, including pregnant women, people with heart or lung disease or anemia, those under the influence of alcohol, and those at high altitudes.

It is against federal regulations to operate wood heaters in a manner inconsistent with operating instructions in the manual.

MAINTAINING YOUR WRT3820WS FIREPLACE

Creosote - Formation and Need for Removal

When wood is burned slowly, it produces tar and other organic vapors, which combine with expelled moisture to form creosote. The creosote vapors condense in the relatively cool chimney flue of a slow-burning fire. As a result, creosote residue accumulates on the flue lining. When ignited this creosote makes an extremely hot fire.

The chimney shall be inspected at least twice a year during the heating season to determine when a creosote buildup has occurred.

When creosote has accumulated it shall be removed to reduce the risk of a chimney fire.

When the creosote accumulation is large, a creosote fire in the chimney can damage the chimney and overheat the surrounding wood framing. Creosote formation in a chimney can be minimized by making sure there is always visible flame burning, avoid smouldering fires and by proper refuelling techniques.

Chimney Maintenance

Regular chimney inspection and maintenance combined with proper operation will prevent chimney fires. Keep your chimney clean. Do not allow more than 1/16" (1.6 mm) creosote build up in your chimney. The amount of creosote will depend on variables such as frequency of use and type of fire. We recommend that you:

- A. Initially inspect the chimney system weekly. From this, you will learn how often it will be necessary to clean your chimney.
- B. Have your chimney cleaned by a qualified chimney sweep. If you wish to clean it yourself, we recommend using a stiff plastic or non-metallic brush. If a metal brush is used, its size should be slightly smaller than the flue to avoid damaging the chimney. Do not use a brush that will scratch the stainless steel interior of the chimney.
- C. Do not expect chemical cleaners to keep your chimney clean. The rain cap can be removed for inspection and/or cleaning of the chimney.

Dealing With a Chimney Fire

Regular chimney maintenance and inspection can prevent chimney fires. If you have a chimney fire, follow these steps:

1. Close the fireplace door and the combustion air controls.
2. Alert your family of the possible danger.
3. If you require assistance, alert your fire department.
4. If possible, use a dry chemical fire extinguisher, baking soda or sand to control the fire. Do not use water as it may cause a dangerous steam explosion.
5. Check outside to ensure that sparks and hot embers coming out of the chimney are not igniting the roof.
6. Do not use the fireplace again until your chimney and fireplace have been inspected by a qualified chimney sweep or a Fire Department Inspector.

Top Baffle Removal Prior to Cleaning The Chimney

Before starting to clean your chimney, we recommend that you remove the top baffle to avoid creosote dust collection at the top of the baffle. Follow these steps to set the top baffle out of the way:

1. Slide the front baffle to the front of the unit.
2. Lift the back baffle and slide it over the front baffle

You now have access to the chimney

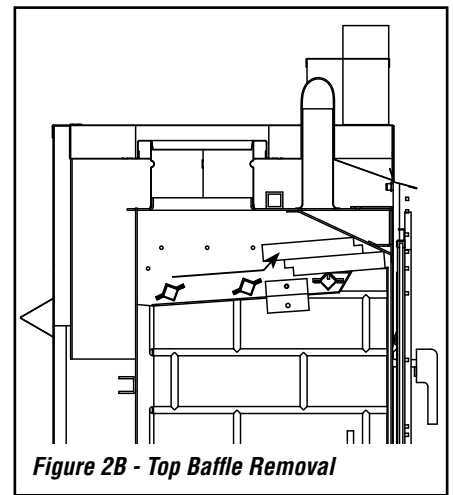
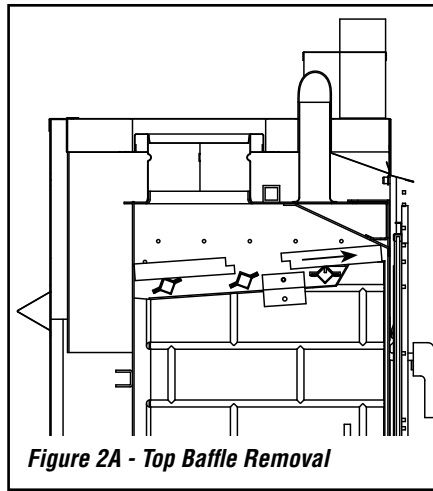

Finish Door Casing Care

Use a glass cleaner and a soft cloth to polish the casing. Do not use abrasives such as steel wool, steel pads or an abrasive polish for they may scratch the casing's finish.

DISPOSING OF ASHES

Remove ashes only when the fire is out and the ashes are cold (24 to 48 hours after the fire is out).

Do not leave the ashes in the house as they give off carbon monoxide and other toxic gases.

! WARNING

Disposal of Ashes: Ashes should be placed in a steel container with a tight fitting lid and moved outdoors immediately. The closed container of ashes should be placed on a non-combustible floor or on the ground well away from all combustible materials, pending final disposal. If the ashes are disposed of by burial in soil or otherwise locally dispersed, they should be retained in the closed container until all cinders have thoroughly cooled.

REFRACTORY REPLACEMENT

The intense heat of the fire will normally cause hairline cracks in the refractory. These cracks can be minimized by proper curing as described in "First Fires". They will not normally diminish the effectiveness of the refractory. If large cracks develop, then the refractory should be replaced. To replace the refractory bricks, follow these steps (see *Figure 3*):

1. Remove the bottom refractory
2. Remove the front refractories
3. Remove the left side refractory
4. Remove the right side refractory
5. Remove the back refractory
6. Remove the front ceramic baffle
7. Remove the rear ceramic baffle

To install the new refractories, follow the above steps in reverse.

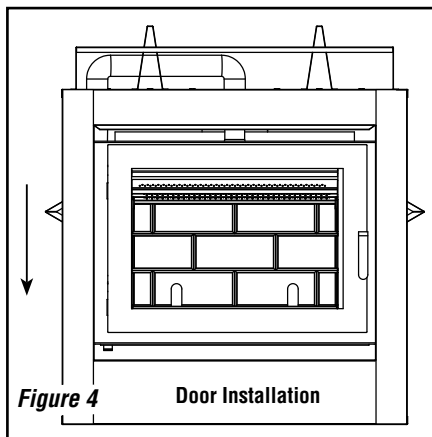

Figure 4 Door Installation

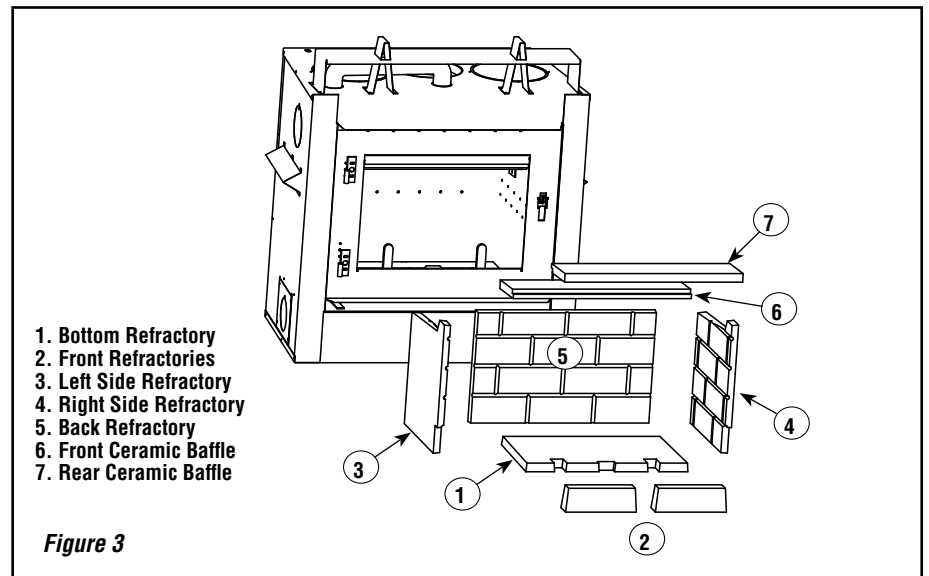

Figure 3

DOOR REMOVAL

To remove the door, simply pull the door up from the hinges (see *Figure 4*). The door adjustment has been set at the factory. If the fit is still not perfect, you can adjust the door using the hinge screws.

DOOR ADJUSTMENT

The door may need to be adjusted to be completely airtight. The gaskets' air-tightness can be adjusted using two adjustment screws located on the right side of the fireplace facade (An Allen key #1/8 – not supplied - will be necessary for this adjustment).

Checking Door Seal

A one-inch strip of paper may be used to perform a test of the integrity of the door seal. Close the door on the paper in at least eight points. It is normal to feel only a slight amount of friction. The door gasket does not need to be "tight" in all areas, since a small amount of leakage is not hazardous or detrimental to the performance of your fireplace.

! WARNING

- Use only a IHP glass doors, specifically designed for the WRT3820WS fireplace.
- The fireplace cannot be operated without door or firescreen. Consult your dealer to select the correct replacement door or firescreen.
- Important! To assure proper alignment of glass doors: Install this fireplace in a square and plumb condition, using shims as necessary at sides and/or bottom.

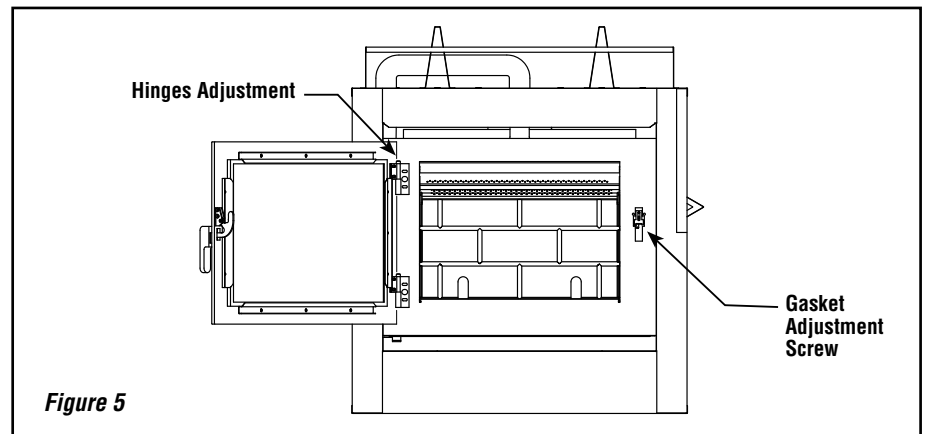

Figure 5

GLASS CARE

Glass Replacement

The glass used for the WRT3820WS fireplace is a high temperature ceramic glass (1,400° F / 760° C). If the glass breaks, it must be replaced with an identical ceramic glass. Tempered glass or ordinary glass will not withstand the high temperatures of the WRT3820WS fireplace. Replacement glass should be purchased from a IHP dealer (see "Replacement Parts", **Page 24**). **DO NOT OPERATE THE UNIT WITH CRACKED OR BROKEN GLASS.**

Glass Cleaning

The WRT3820WS fireplace is designed to keep the glass clean under normal operating conditions. If the WRT3820WS fireplace is operated continuously with the combustion air controls closed, the glass will tend to get dirty unless the fuel, firebox and glass are maintained at hot temperatures (see "Refueling For Best Performance"). To clean the glass, there are a number of specially designed cleaners. Your IHP dealer can recommend a suitable cleaner which is available in your area. Regular household glass cleaners will not clean creosote. **Do not use abrasives such as steel pads, steel wool or oven cleaner as they will scratch the glass.**

DO NOT USE CHEMICAL GLASS CLEANERS ON PAINTED SURFACES AS IT MAY CAUSE THE PAINT TO PEEL.

CAUTION: DO NOT ALLOW WINDOW CLEANER TO GET IN CONTACT WITH DOOR GASKET OR PAINT ON FACADE OR DOOR. ONCE CLOSED, CONTACT OF GLASS CLEANER WITH THE FIREPLACE FACADE CAN PROVOKE PAINT PEELING OFF.

Gasket Replacement

Remove the door from the unit (see **Page 7**) and lay it on a clean unabrasive surface. To replace the gasket, first remove all of the old gasket and gasket cement. Make sure that the surface is totally clean before applying new cement (a high temperature silicone caulking rated at 500° F [260° C], is suitable) or adhesion problems may result. Apply gasket cement to the gasket channel and install the new gasket. This replacement part is available from your IHP dealer in the following dimensions:

Gasket	Length*	Dimensions	Part No.
Around Glass	69 (1753)	1 x 3/16 (25 x 4.8)	PR-SR1685H
On Door Frame	73 (1854)	3/4 dia (19.5)	PR-SR18230

Table 1 * NOTE: Inches (millimeters)

FIREPLACE INSTALLATION

Locating The WRT3820WS Fireplace

The best location to install your fireplace is determined by considering the location of windows, doors, and the traffic flow in the room where the fireplace is located, allowing space in front of the unit for the hearth extension and the mantel, and taking into consideration the location of the hot air ducts (optional), outside air kit (optional) and chimney.

If possible, you should choose a location where the chimney will pass through the house without cutting floor or roof joists (see fireplace dimensions **Page 10**).

Usually, no additional floor support is needed for the fireplace. The adequacy of the floor can be checked by first estimating the weight of the fireplace system. Weights are given on **Page 24**. Note the floor construction and consult your local building code to determine if additional support is needed.

The WRT3820WS fireplace may be installed directly on the floor or on a raised base (for proper guidelines, refer to "Hearth Extension Requirements") and a minimum of 6'8" (2 m) measured from the base of the appliance to the ceiling is required.

When selecting the location, the chimney outlet position and the direction of the wind are important factors affecting the chimney performance. To allow a maximum draft and to reduce wind turbulence, the chimney must:

- Penetrate the highest part of the roof.
- Be installed as far as possible from roof offsets, trees or any other obstructions that may cause wind turbulence and back drafts in the chimney.
- The least amount of offsets (elbows) possible. **NOTE: A maximum of 2 offsets is allowed.**

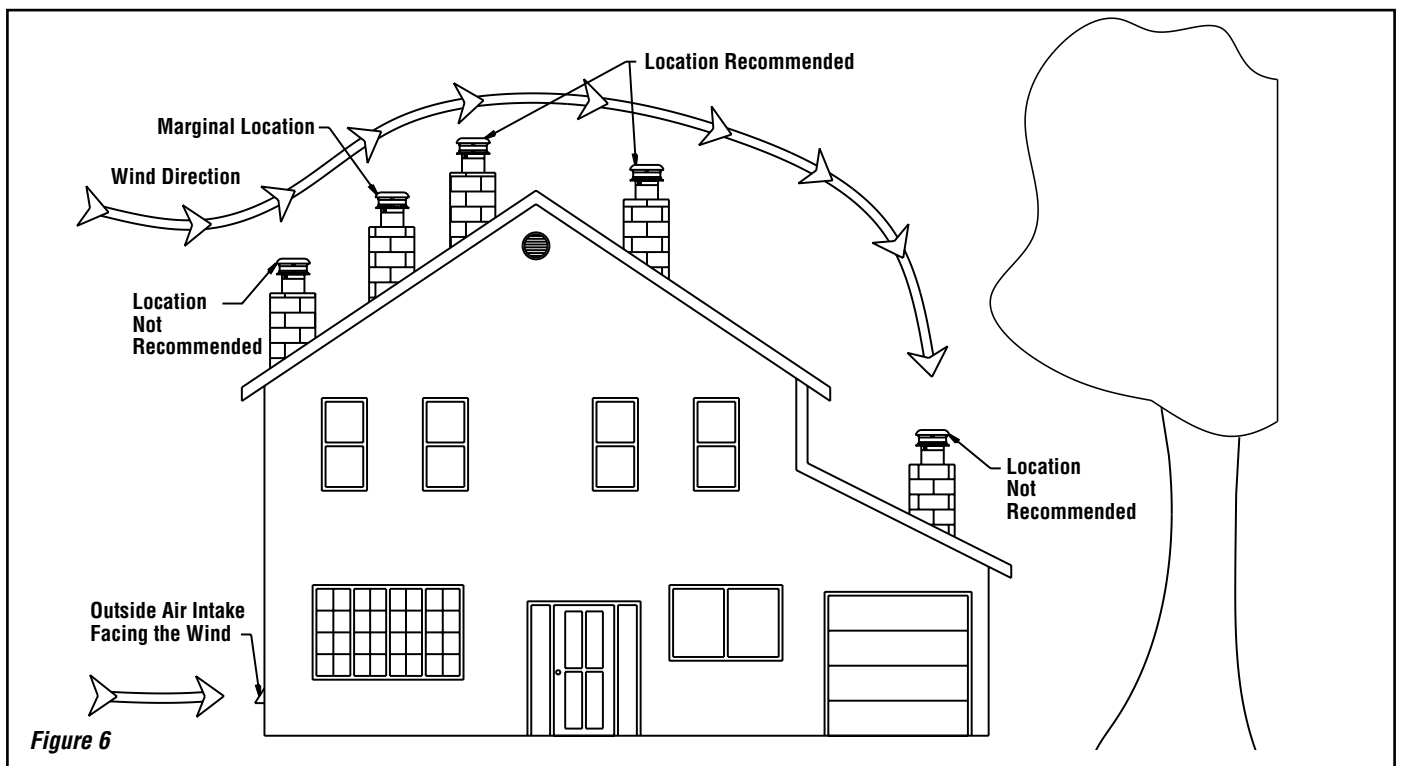

Figure 6

Optional Cast Facade installation

Install the Facade per instructions provided in Facade Kit (ordered separately - see **Page 22**).

Framing, Facing And Mantel

The construction of the framing, facing, and mantel must be in accordance with the standards and the following illustrations (**Figures 8 and 9**):

- A. Frame the fireplace using 2" x 3" or heavier lumber.
- B. **WARNING: Combustible materials cannot be used in the space directly above the fireplace, except for the studs above the facade that support the facing and mantel. This area must remain empty for a height of 6'8" (2,032 mm) measured from the base of the appliance.**
- C. Frame the fireplace with vertical studs at the sides of the fireplace running from floor to ceiling (see **Figure 8**). If combustible facing is to be used, position the studs back, from the front edge of the fireplace (a space that is the thickness of the facing material, so that the facing can be installed flush with the fireplace facing). Frame headers between the vertical studs only as follows:
- Place 2" x 3" or 2" x 4" headers, only along the upper part of the front, side and back faces (some codes may require a 2" x 6" on an outside bearing wall). Do not put wood or any combustible material within the area above the fireplace except on the front facing.
 - Place headers only as required to support the facing and mantel.
- D. **WARNING: The fireplace must not be in contact with any insulation or loose filling material. Cover the insulation with drywall panels around the fireplace.**

Hearth Extension Requirements

The WRT3820WS fireplace may be installed directly on a combustible floor. The supplied safety metal strip must be positioned as follows: One half under the front of the fireplace and the other half must extend on the floor over which the hearth extension will be built (see **Figure 7A**).

* The safety metal strip must cover the entire width of the fireplace

The combustible floor in front of the fireplace must be covered with at least a 1/2 inch of non-combustible material (tile, marble, stone, etc). See **Figure 7B**.

COLD CLIMATE INSTALLATIONS

Climates where temperatures will fall below 32° F (0° C).

The heating performance of the appliance will vary depending upon the level of insulation, house design, how the appliance is operated, etc.

If this fireplace is being installed in a cold climate, it is especially important to seal all cracks around the fireplace and wherever cold air could enter the room with noncombustible material.

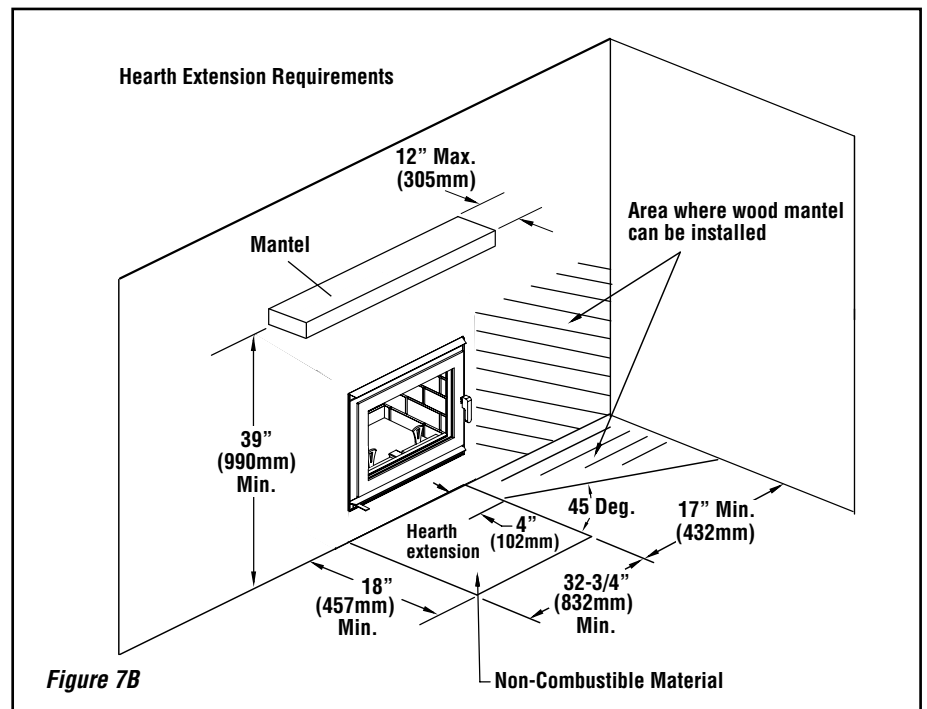
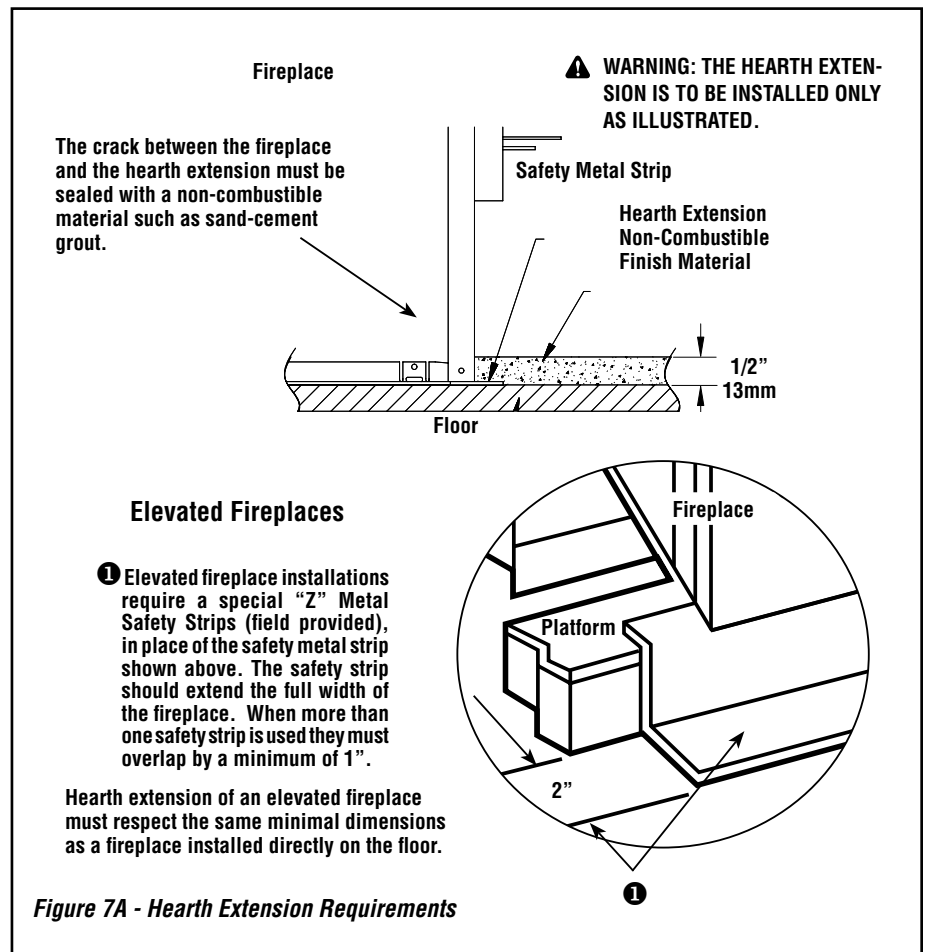

Also, the outside air inlet duct should be wrapped with noncombustible insulation to minimize the formation of condensation. Do not place insulation materials directly against the chimney sections. We recommend that you use the insulated wall radiation shield since it will maintain the home's thermal barrier. AC chimney is NOT recommended in very cold climates (in areas with temperatures below 32°F (0°C)).

FRAMING DIMENSIONS		
A	36"	914 mm
B	38"	965 mm
C	29-1/8"	740 mm
D	12-1/2"	318 mm
E	70"	1778 mm
F	35"	889 mm
G	*22"	559 mm
J	49-1/2"	1257 mm
K	8"	203 mm

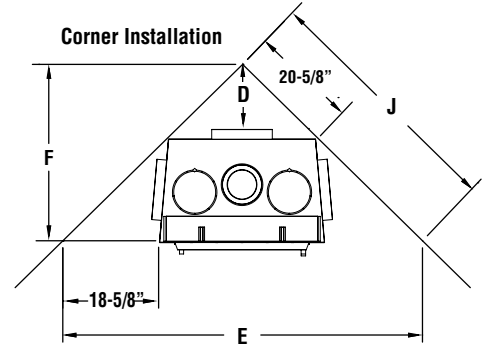
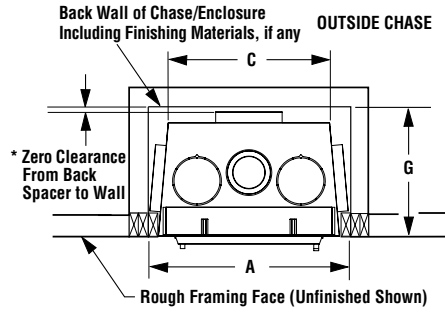

Combustible materials can NOT be used in the space directly above the fireplace. Do not fill the space above the fireplace with any material (Except the wood framing)

* Total depth is 22-1/2 inches (572mm) including the back spacer minus 1/2 inch (13mm) for drywall to be flush with the facing.

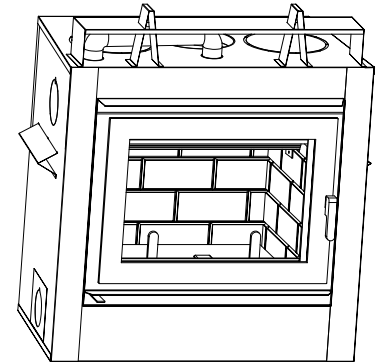
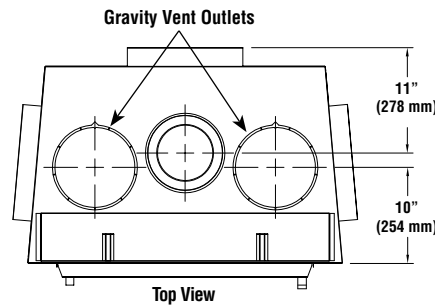
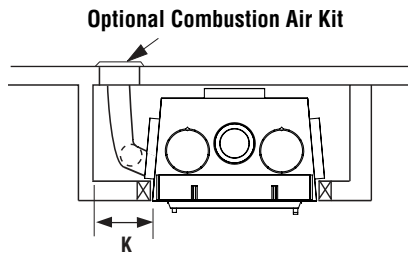
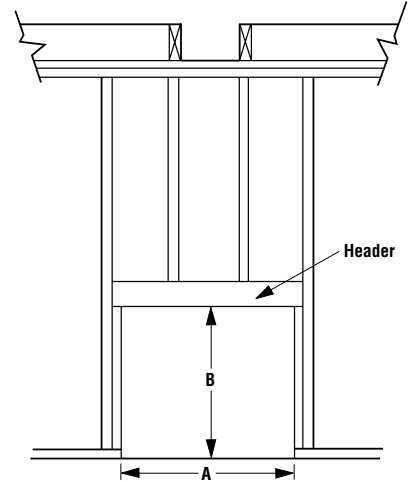
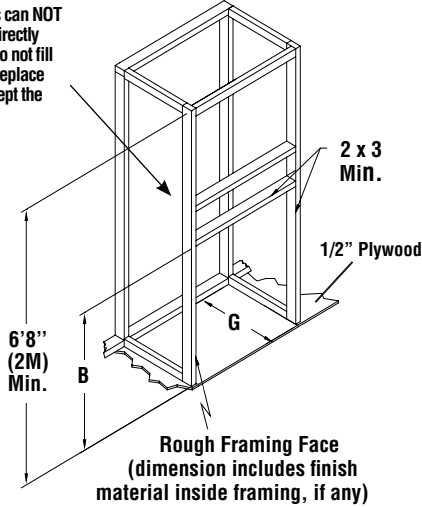

NOTES

Diagrams, illustrations and photographs are not to scale - consult installation instructions. Product designs, materials, dimensions, specifications, colors and prices are subject to change or discontinuance without notice.

All framing dimensions calculated for 1/2" dry wall at the fireplace face. If sheathing the chase or finishing with other thickness materials, calculations will need to be made.

* The fireplace must not be in contact with any insulation or loose filling material. Cover the insulation with Drywall panels around the fireplace.

WARNING: IF YOU ARE INSTALLING THE CAST FACADE PLEASE REFER TO THE INSTALLATION SHEET PROVIDED WITH THE CAST FACADE TO PLAN YOUR INSTALLATION.

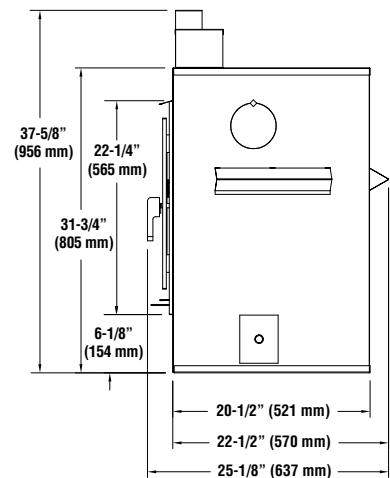
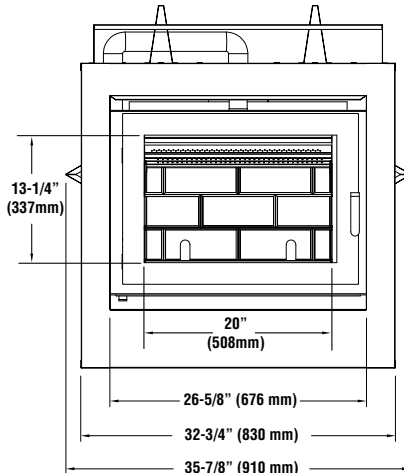
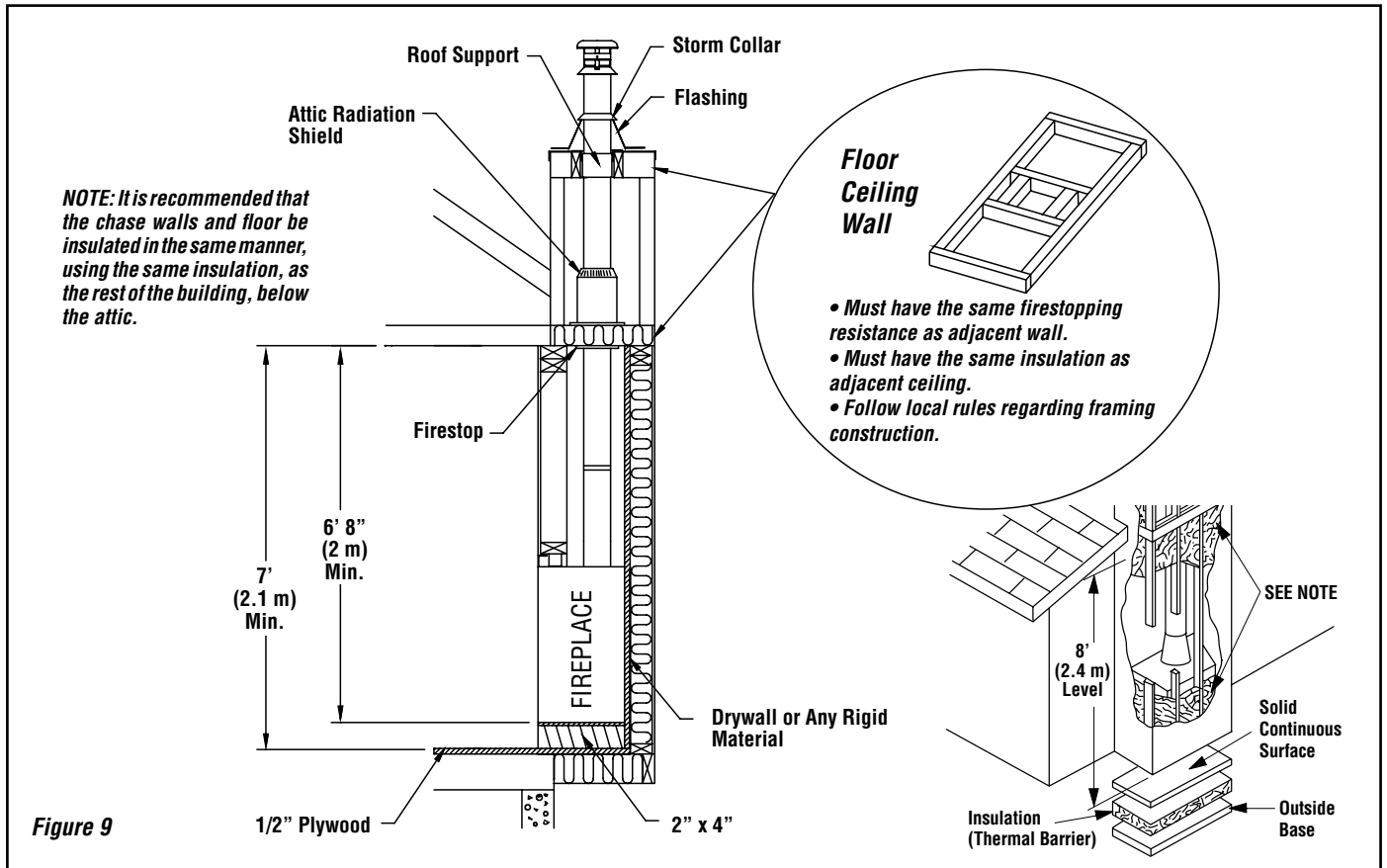

Figure 8 - Framing Dimensions

Insulated Chase Construction



Nailing Flanges

Four nailing flanges are provided to secure the fireplace to the floor (see figure below). Bend the nailing flanges down so that each flange is flush with the floor, then using nails or screws, secure the fireplace to the floor (2 places each side). The heads of the screws or nails must be large enough to completely cover the holes in the nailing flanges.

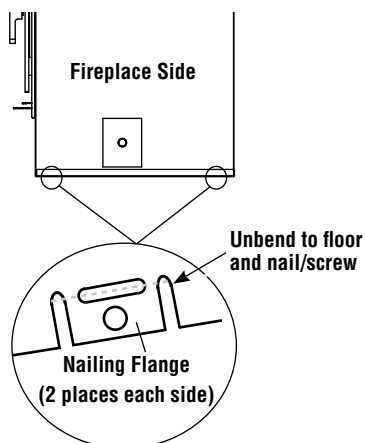

Mantel and Facing

The mantel must be installed at least 39" (990 mm) above the base of the fireplace (**Figures 7b and 11**).

Facing

1. Combustible material must be installed flush with the fireplace. It may not project in front of and on the fireplace (i.e. the steel facade of the fireplace) (**Figure 10**).
2. Non-combustible materials such as brick, stone or ceramic tile may project in front of and onto the fireplace facing up to the tiling flange (**Figure 13**).

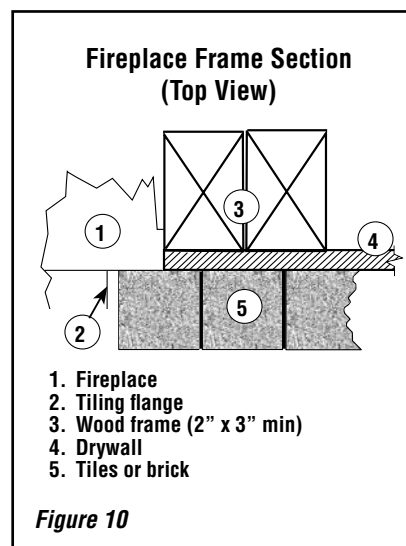

Mantel and Facing (Side View)

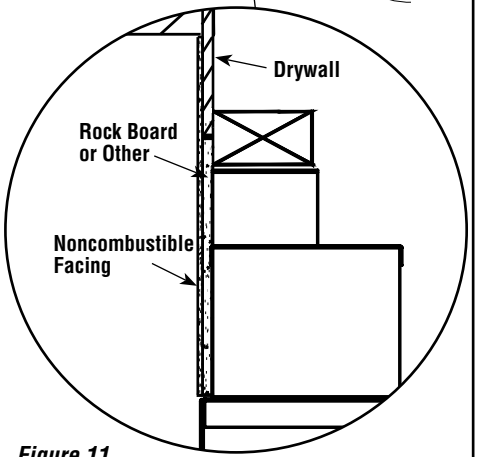
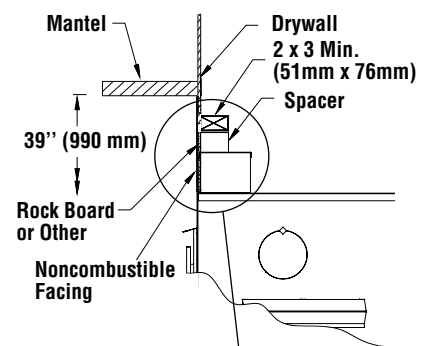

Figure 11

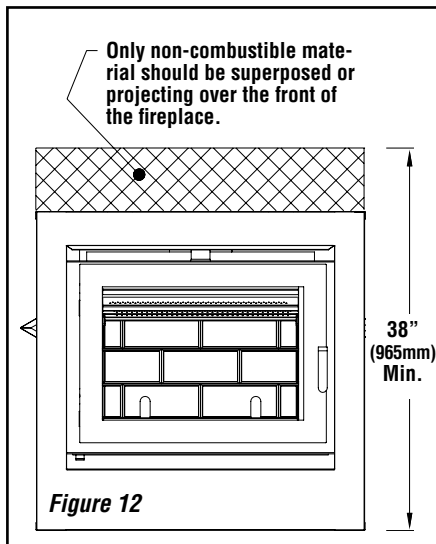

Figure 12

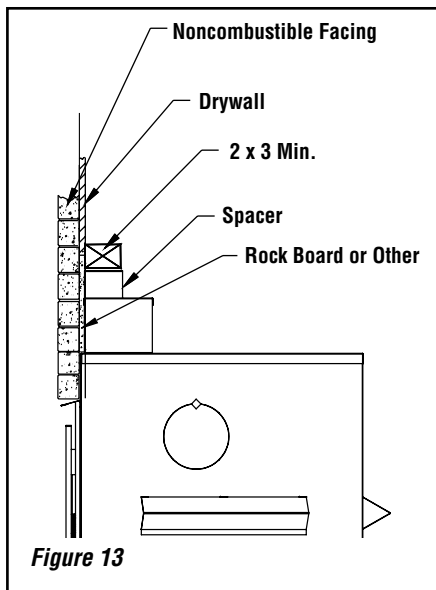

Figure 13

FIREPLACE BLOWER

The fireplace is equipped with a blower. It is located in the bottom of the fireplace towards the back. It uses 120V and must be connected to the main electrical circuit by a qualified electrician prior to enclosing the fireplace.

For connection, use the electrical box supplied with the unit located on the bottom right side of the fireplace. To access the electrical box remove the four screws, pull out the plate and box and install the electrical receptacle.

A wall on/off switch must be installed to control the blower. An optional heat switch and variable speed control are available (see [Page 22](#)).

If installed, the heat activated switch must be connected to the blower main cable and the magnets must be stuck under the fireplace firebox accessible through the side electrical box access plate.

If a repair must be done after the fireplace is installed an access plate is located under the bottom refractory. Remove the bottom refractory, unscrew the access plate, clean black cement sealing the access plate and do the repair.

Once the repair is done, it is mandatory to apply a new high temperature black cement (Mill-Pack, available from your retailer) sealing the access plate and all screw holes. Because the WRT3820WS fireplace is an air tight fireplace, failure to do so will reduce fireplace efficiency. Tightly screw the access plate back on place and reinstall the bottom refractory.

HOT AIR DUCTING INSTALLATION

The WRT3820WS fireplace is approved for use with a Gravity kit (hot air ducting system).

Gravity Kit

The gravity kit is designed for double hot air outlets and includes: (See [Figure 14](#)).

- Two (2) telescopic lengths 8" I.D.
- Two (2) 90° elbows 8" I.D.
- Two (2) hot air outlet kits (grill and frames)
- Two (2) adaptors

See [Gravity Kit Accessories Page 22](#).

For safe installation, the gravity kit must meet the following requirements:

- Minimum height*** 68" (1,727 mm)
- Maximum length** See [Figure 15](#)

* The height of the louver must be measured from the base of the WRT3820WS fireplace to the middle point of the louver.

The only blower that can be used with the gravity kit is the one sold with the fireplace.

To extend the double outlet system, it will be necessary to purchase two adjustable lengths (H8951).

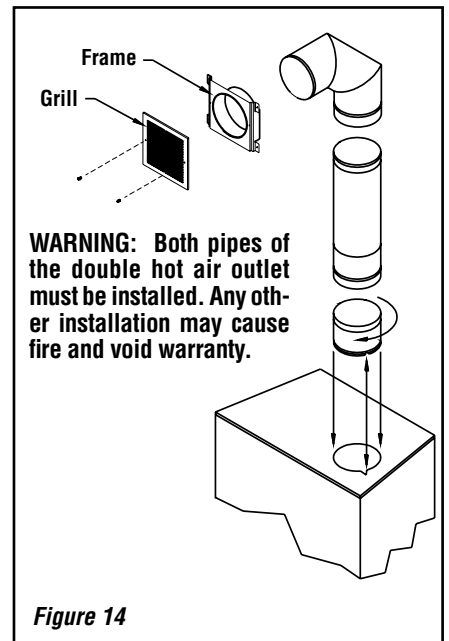

Figure 14

When installing the double outlet system, the hot air outlets can be installed in the same room as the fireplace, or one or both of the outlets can be installed in adjacent or upper rooms. Installing the ducts at different elevations will tend to exhaust more heat out of the higher outlet ([Figure 15](#)).

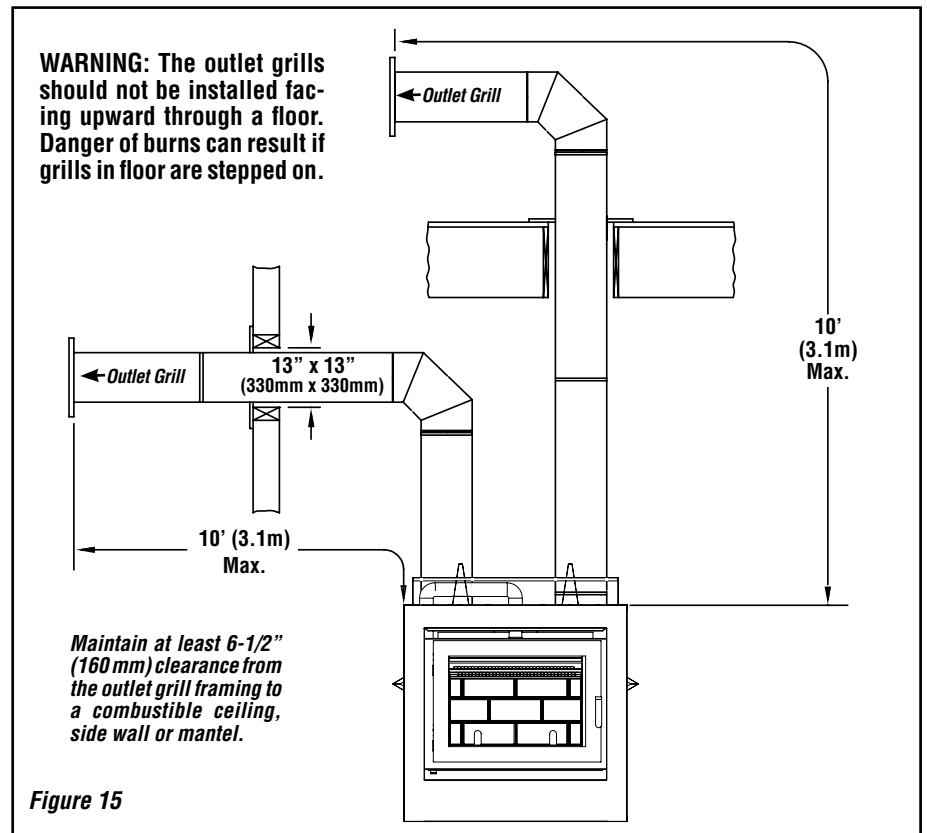

Figure 15

Central Forced Air Kit

NOTE: Not tested under EPA certification. If installed, this appliance no longer qualifies for EPA certification.

The knock-outs provided on the back and on the sides of the WRT3820WS fireplace allow the connection of insulated flexible pipe which enables you to heat adjacent rooms up to 50 feet from the fireplace hot air outlet.

The ducting system must be installed as described below:

- A) Remove knock-out plate and cut insulation the adaptor at the back and/or the side of the fireplace. Fix the adaptor by twist-locking it to the fireplace. You can use more than one outlet on the fireplace (see **Figure 17**).
- B) Attach the 5" flexible pipe, using the collars provided. **Important: Make sure that the plastic wrapping around the flexible pipe will not be in contact with the fireplace.**
- C) Route the flexible pipe to the chosen location. The ducting system can be installed either in an upper room or in a lower room.
- D) Attach the flexible pipe to the blower, using the collars (**Figure 18**).
- E) Fix the back draft damper to the blower outlet.
- F) Attach a flexible pipe to the fan / flexible pipe adapter (square to round) and stretch it up to the location where the heat is required.
- G) At that point, the flexible pipe can be attached to any air distribution grill.
- H) Install the blower heating and cooling thermostat (HCTW) in that part of the house to be heated by the hot air duct. The thermostat can be switched to a cooling thermostat and installed in the same room as the unit. This thermostat will turn on the blower when the room where the fireplace is located becomes too hot.

This option requires electricity. Make sure that the connections to the blower have been made according to the local codes and comply with their requirements (see instruction provided with the thermostat). For more information regarding central forced and ducting, refer to the BISFWK-1 installation sheet provided with the kit.

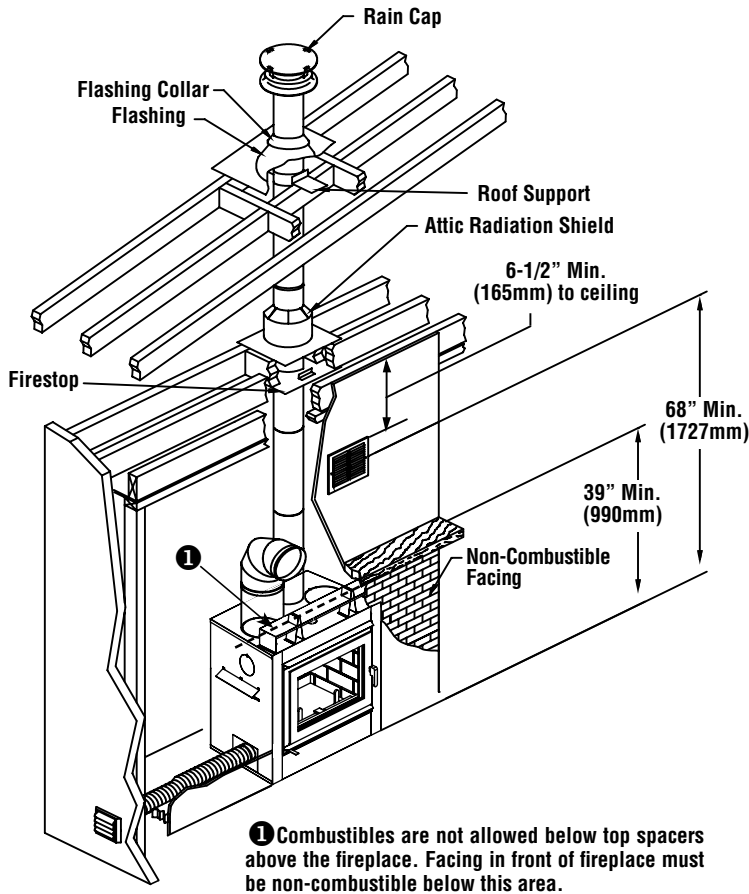

Figure 16

The duct system must be installed respecting the following:

1. Remove the plates closing up the 8" dia. holes on top of the fireplace. Then, cut the insulation in order to obtain two 8" dia. openings. Fix the adaptors on the fireplace openings by turning clockwise (**Figures 14 and 15**).
2. Maintain at least a 2" (50 mm) clearance between the ducts and any combustible material; the required hole size is 13" x 13" (330 mm x 330 mm).
Exception #1: For the grills, the framing can be 10-3/4" x 10-3/4" (275 mm x 275 mm) to provide the clearance as required by the integral spacers on the double outlet duct system.
3. The maximum number of elbows in a run of duct is two.
4. Maintain at least 6-1/2" (160 mm) clearance from the outlet grill framing to a combustible ceiling, side wall, mantel or floor.
5. When traversing a combustible wall or floor, a firestop must be installed at the wall or floor penetration. The hole size must be 13" x 13" (330 mm x 330 mm)

6. Do not connect the hot air ducts to a central heating system. Malfunction of the heating system's blower will cause the fireplace to overheat. A furnace duct is only single wall and not double wall as is required for the WRT3820WS fireplace hot air exhaust.
7. Use only IHP grills and components as described in this manual. Other grills or registers, for example, may be too restrictive and may overheat the fireplace or ceiling.
8. Do not use insulated flexible ducts as they will overheat.
9. Do not use tees or any other components than the ones specifically listed here.
10. Never allow the ducting to pitch down as hot air will be trapped creating a fire hazard. **Never route the ducting downwards.**
11. The hot air outlet grills must be installed with the louvers pointing downwards in order to prevent overheating adjacent ceilings.

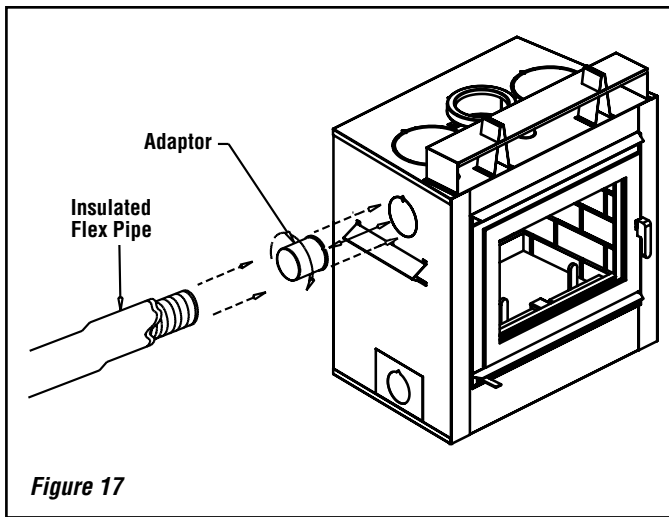

Figure 17

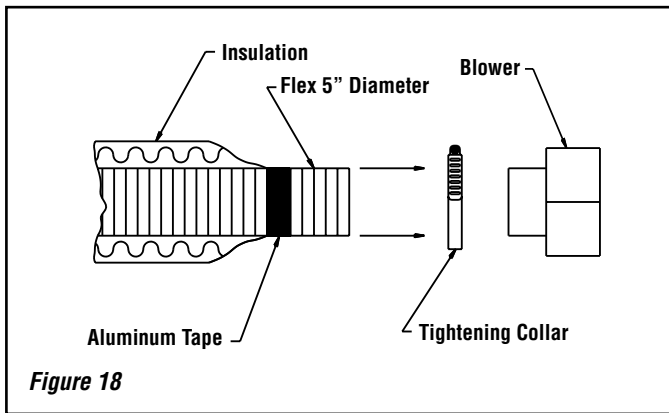

Figure 18

OUTSIDE AIR KIT (fireplace and AC chimney)

The outside air kit is optional on the WRT3820WS fireplace, but mandatory on the AC chimney. It can be burned drawing air only from the house. When the fireplace is in operation with the door closed, it will pull only a slight amount of air from the house. Nevertheless, the outside air kit might be mandatory in your jurisdiction, check your local building code.

To install an outside air intake on the fireplace:

1. Remove the obstruction plate and the access plate (both are super-impose) located on the bottom of the left side (*Figure 19, part 2*).
2. Screw the obstruction plate inside the primary air box using only two screws on the bottom (*Figure 19, part 3*).
3. Reinstall the access plate exposing the 5 inch diameter hole topped by a triangle (*Figure 19, part 4*).

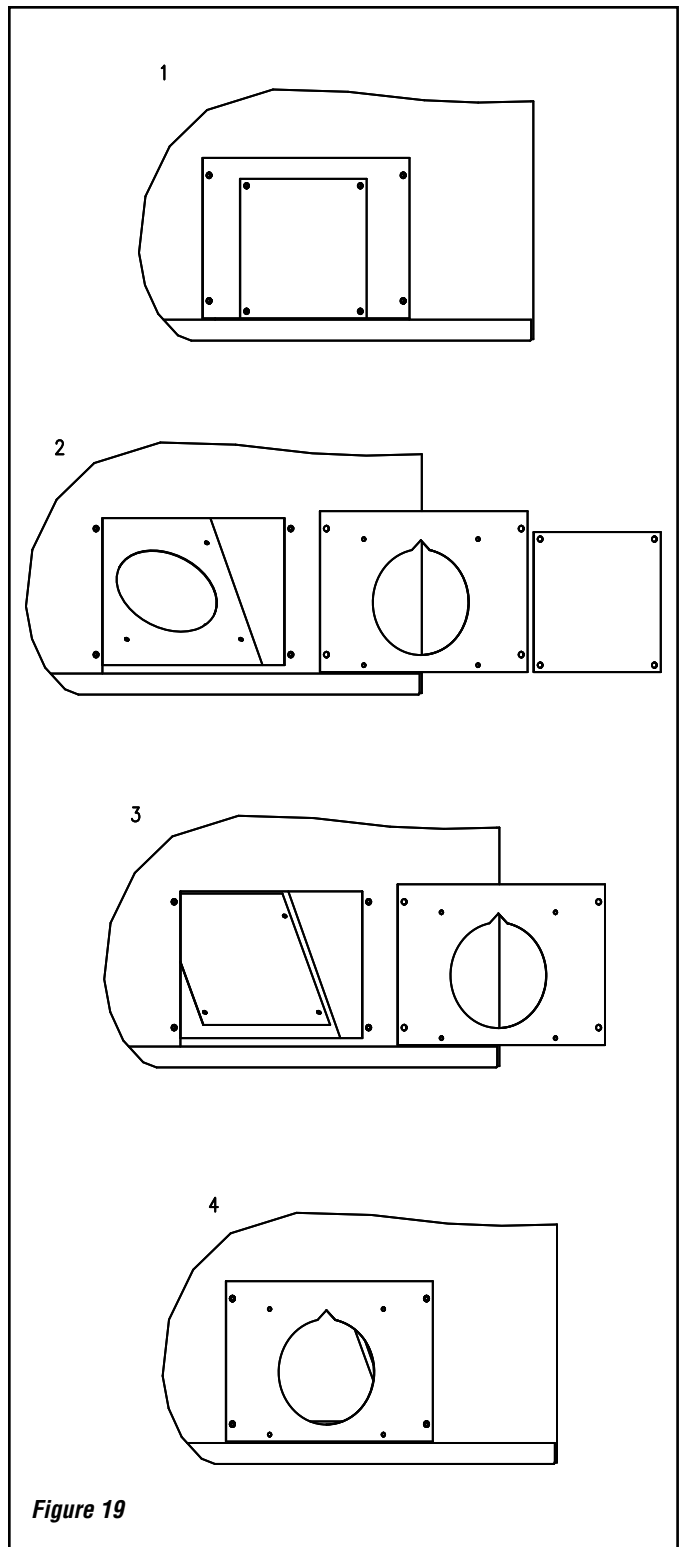

Figure 19

Outside Air Installation

The outside air assembly may be installed according to the following requirements:

- Duct length should be kept to a minimum. The maximum length of a 4" interior diameter (100 mm) insulated flexible duct is twenty (20) feet (6.1 m). (See note below).
- The air intake register must not be installed more than ten (10) feet (3050 mm) above the base of the fireplace.
- The fresh air must come from outside the house. The air intake must not draw air from the attic, basement or garage.
- The air intake should be installed where it is not likely to be blocked by snow or exposed to extreme wind and away from automobile exhaust fumes, gas meters and other vents.
- The duct and register may be installed above or below floor level.

Make a 4-1/4" (110 mm) hole in the outside wall of the house at the chosen location. From outside, place the outside air register in the hole (open side down) and fasten the register to the wall with screws as shown (see **Figure 20**). Slip the pipe into the insulated sleeve. Place the insulated pipe over the register tube and over the fireplace's outside air connector (see **Figure 21**). At each end, carefully pull back the insulation and plastic cover exposing the flexible pipe. Using the aluminium tape provided, wrap the tape around the joint between the flexible pipe and the air inlets. Carefully push the insulation and plastic cover back over the pipe. Using aluminium tape, fasten the plastic cover in place.

NOTE: We recommend not to exceed twenty (20) feet of 4" flexible pipe. If you require a longer length we recommend that you use a 5" diameter flexible pipe for the complete run up to thirty (30) feet and a 6" diameter pipe for a run of up to forty (40) feet.

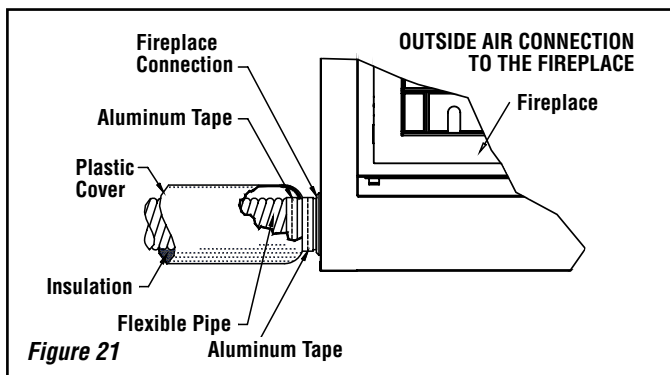
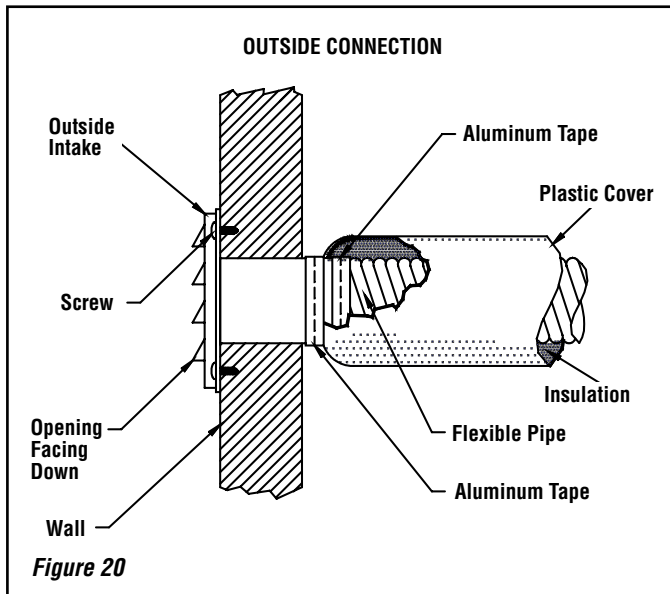

THE CHIMNEY SYSTEM

Chimney Installation Notes

- If possible, install an interior chimney as it will provide better performance. In areas with continuous temperatures below -18° C (0° F), the use of an exterior chimney increases the likelihood of operating problems such as low draft, high rate of creosoting, and poor start-up characteristics. Exterior chimneys are also prone to down-draft and flow reversal. Installations, which are located on lower floors in the house, such as in a basement, in combination with outside chimney, are especially prone to flow reversal.
- The IHP fireplace model WRT3820WS may be installed only with Security Chimneys International Ltd 6" diameter chimney systems. The WRT3820WS fireplace may also be installed with a 7" chimney system (ASHT* or HT6103*) using the optional 6AW7*7" adaptor (7" AC chimney is not allowed). For more information refer to chimney installation manual.
- A chimney venting a fireplace shall not vent any other appliance.
- The minimum chimney height is twelve (12) feet (3.7 m). In altitude, add 18" (450 mm) to the chimney for every 2,000 feet (600 m) above sea level.
- All chimney* installations must include at least one support.** Reducing the amount of chimney weight on the fireplace will help avoid the noise created when the fireplace expands. This can be achieved by having the chimney supported by the supports. The maximum chimney length that can be supported by the fireplace is nine (9) feet (2.75 m) for S-2100+/HT6000+, twelve (12) feet (3.7 m) for ASHT+ / HT6103+ and 26 feet (8 m) for AC chimney.
- The chimney must extend at least three (3) feet (915 mm) above its point of contact with the roof and at least two (2) feet (610 mm) higher than any wall, roof or building within ten (10) feet (3m) of it (**Figure 22**).
- If the chimney extends higher than five (5) feet (1,500 mm) above its point of contact with the roof, it must be secured using a roof brace.
- A rain cap must be installed on top of the chimney. Failure to install a rain cap may cause corrosion problems.
- Cut and frame square holes in all floors, ceilings, and roof that the chimney will go through to provide a 2" (50 mm) clearance between the chimney and any combustible materials. Do not fill this 2" space with insulation or any other combustible material.
- Portions of the chimney which may extend through accessible spaces must be enclosed to avoid contact with combustible materials or damage to the chimney.
- When offsets are used, the pipe may not penetrate a ceiling or floor unless it is running vertical (no 30° offsets).

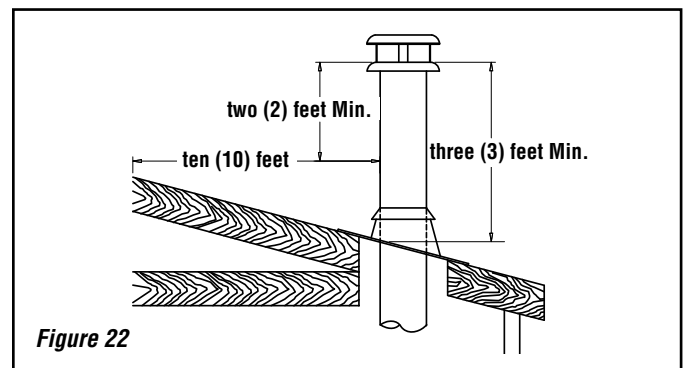

NOTE: 2" clearance to combustibles around chimney components required.

NOTE: Blown or fill type insulation materials must not be in contact with the fireplace or in the enclosure frame as described in "Enclosure" section.

NOTE: Local codes may not require firestopping at the ceiling levels for outside chase installations. However, it is recommended for safety and the reduction of heat loss.

CHIMNEY INSTALLATION INSTRUCTIONS

1. Cut and frame the holes in the ceiling, floor and roof where the chimney will pass (see **Figure 23**). Use a plumb-bob to line up the center of the holes. The sizes are indicated in **Table 2** for the floor and ceiling holes and **Table 3 (Page 17)** for the roof holes.

CHIMNEY MODEL *	SQUARE HOLE SIZE OPENING
6"	
ASHT+ / HT6103+	12-3/8" (314 mm)
S-2100+ / HT6000+	14-1/8" (359 mm)
AC	15 in (380 mm)

NOTE: See Table 3 for Sloped Roof Framing
Table 2 - Flat Roof Framing

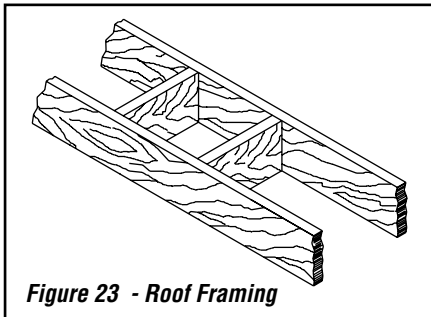

Figure 23 - Roof Framing

2. From below, install a firestop in each ceiling/floor separation through which the chimney will pass. At the attic level, install an attic radiation shield from above (**Figure 24a**).
3. For ASHT+ / HT6103+ and S2100+ / HT6000+ chimneys place the first chimney length on the fireplace. To lock it in place, turn 1/4 of a turn clockwise. With the AC chimney, you must use a starter section before installing the first chimney length (**Figure 25**). Continue installing chimney lengths making sure to lock each length in place.
4. Every time the chimney passes through a ceiling or a wall, install the appropriate firestop. When you reach the desired height, install the roof support. When installing a support, slightly lift the chimney system so the weight will lie on the support, not on the fireplace to reduce expansion noises (refer to instructions included with the support).
5. Then, put the roof flashing in place and seal the joint between the roof and the flashing with roofing pitch (see **Figures 26 and 27**). For sloping roofs, place the flashing under the upper shingles and on top of the lower shingles. Nail the flashing to the roof, using roofing nails.
6. Place the spacers and the storm collar over the flashing, and tighten it with the bolt supplied. Finally, seal the joint between the storm collar and the chimney, using silicone caulking.
7. Install the chimney cap. Once the chimney cap is in place, the roof flashing can be washed with a solvent or vinegar and then painted with rust-proof paint.

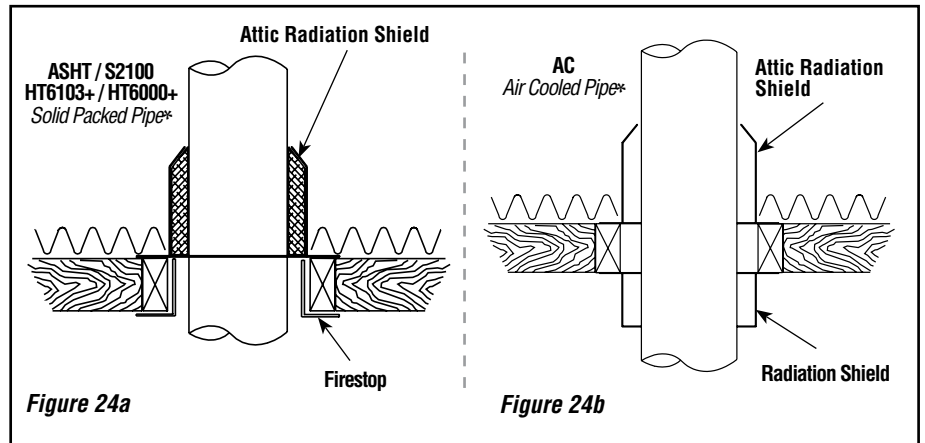

Figure 24a

Figure 24b

AC CHIMNEY* INSTALLATION

(AIR COOLED GALVANIZED CHIMNEY)

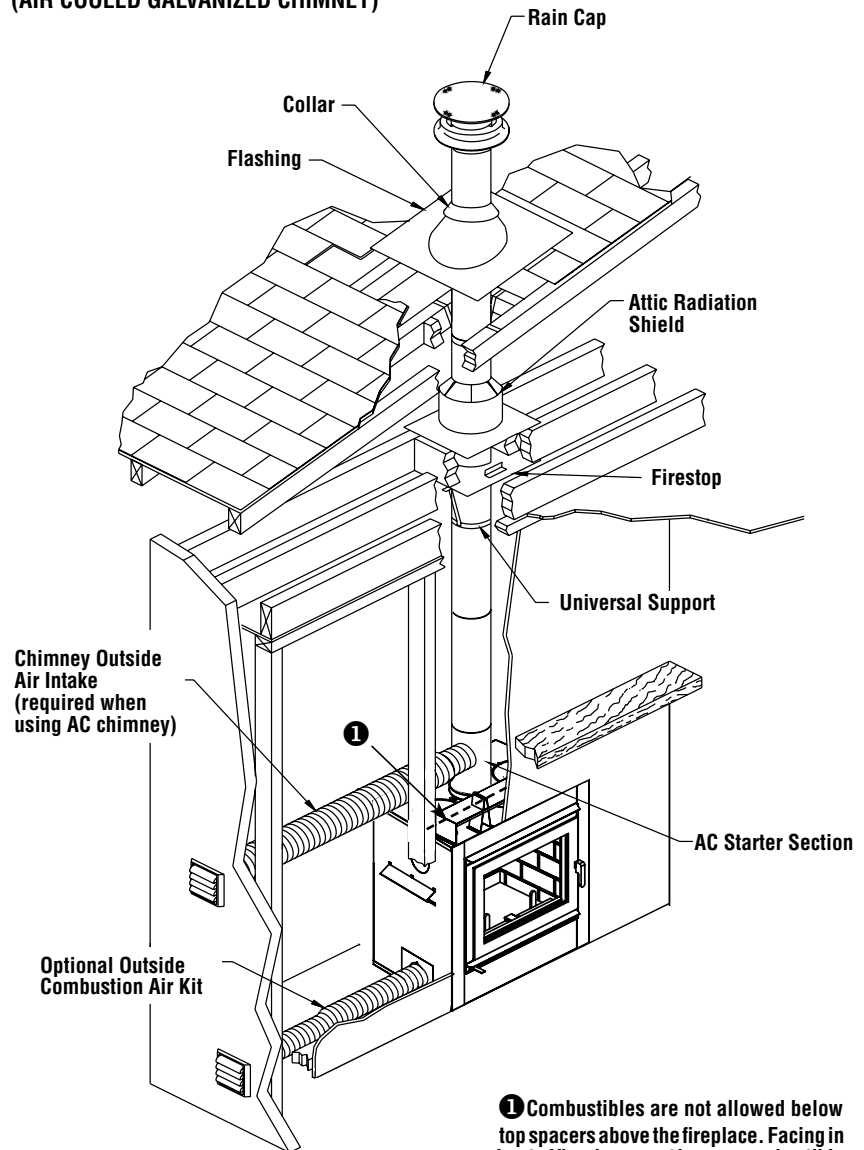
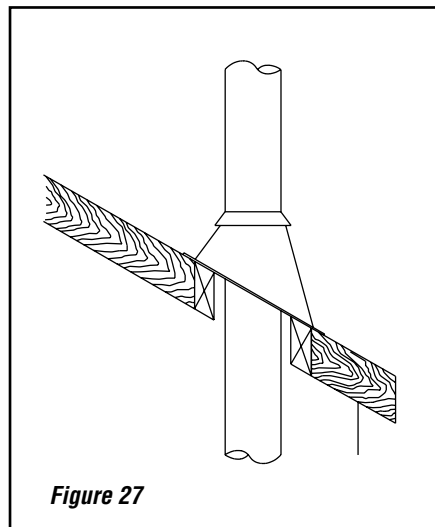
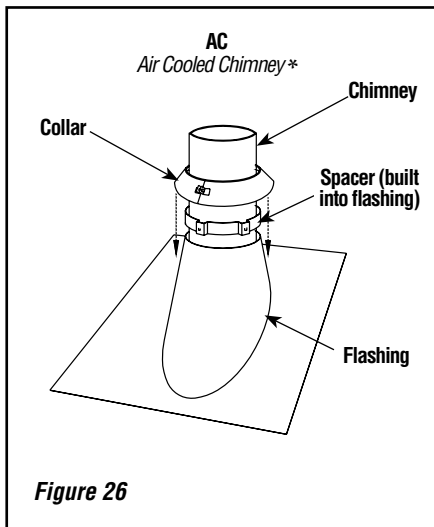

Figure 25

① Combustibles are not allowed below top spacers above the fireplace. Facing in front of fireplace must be non-combustible below this area.



After reaching the location requiring the elbow, proceed as follows:

ASHT+ / HT6103+ / S-2100+ / HT6000+ Chimneys *

1. Install the first elbow; turn it in the required direction. Fasten it to the chimney with the three (3) 1/2" (12 mm) metal screws provided with the elbow.
2. Install the necessary chimney lengths to achieve the required offset. Lock the chimney lengths together: it is recommended to use three (3) 1/2" (12 mm) screws. If the offset length is made of two (2) chimney lengths or more, use an offset or roof support halfway up the offset. If penetrating a wall, install a wall radiation shield (see **Figures 30 and 31**).
3. Use another elbow to turn the chimney vertically. Secure the elbow, using three (3) 1/2" (12 mm) screws (provided with the elbow).
4. Use a plumb-bob to line up the center of the hole. Cut a hole for the chimney in the ceiling/floor. Frame this hole as described previously (refer to section *Chimney Installation Instructions*).
5. From below, install a firestop (See **Figure 24a**).
6. A support (ST* or SO*) must be used on the first 15' section (5 m).
7. Continue with the regular installation.

AC Chimney *

1. Install the first elbow. Turn it in the required direction. To lock it in place, turn 1/8 of a turn. Fasten the straps attached to the elbow to the surrounding frame, using nails or drywall screws (see **Figure 29**).
2. Install the necessary chimney lengths to achieve the required offset. Lock the chimney lengths together. If penetrating a wall, use a wall radiation shield.
3. Use another elbow to turn the chimney vertically. Lock it to the chimney. Fasten the straps attached to the elbow to the surrounding framing using nails or drywall screws.
4. Use a plumb-bob to line up the center of the hole. Cut a hole for the chimney in the ceiling. Frame this hole as described previously.
5. From below, install a firestop (see **Figure 24b**).
6. Continue with the regular installation.

NOTE: When using AC chimney*, an AC6SB* (H3779*) starter section must be used before installing an elbow. When an offset is needed immediately off the top of the fireplace, an elbow starter section, AC6SB30* (H3780*), is available.

Roof Down Slope Hole Size			
SLOPE	ASHT+ / HT6103+ *	S-2100+ / HT6000+ *	AC *
Roof Pitch	6"	6"	6"
0 *	12-3/8" (314 mm)	14-1/8" (359 mm)	15" (380 mm)
2/12	12-9/16" (319 mm)	14-3/8" (365 mm)	15 3/8" (390 mm)
4/12	13" (330 mm)	14-7/8" (378 mm)	16 1/8" (410 mm)
6/12	13-7/8" (352 mm)	15-3/4" (400 mm)	16 7/8" (430 mm)
8/12	14-7/8" (378 mm)	17" (432 mm)	18 1/4" (465 mm)
10/12	16-1/8" (410 mm)	18-3/8" (467 mm)	19 5/8" (500 mm)
12/12	17-1/2" (445 mm)	20" (508 mm)	21 3/8" (545 mm)

* Cross Slope Hole Size
Put the chimney cap into place.
Wash the roof flashing with a solvent or vinegar, then paint it with rust-proof paint.

Table 3

OFFSET CHIMNEY INSTALLATION

After reaching the location requiring the elbow, proceed as follows. The minimum chimney height when using elbows is:

Minimum Chimney Height Using Elbows	
Fireplace Model	WRT3820WS
Chimney Model *	ASHT+ / S2100+ / HT6103+ / HT6000+ / AC
Vertical installation	12 feet (3.66 m)
Two (2) elbows	15 feet (4.57 m)
Four (4) elbows	17 feet (5.18 m)

Table 4

NOTES:

- Must return to vertical before penetrating ceiling or floor.
- A maximum of 2 offsets are allowed.

Offset Dimensions

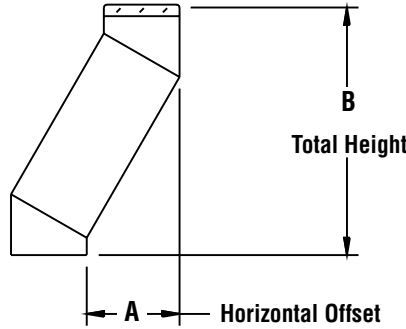

Chimney 6" *	Elbow	Offset & Height	One Length Between Elbows						Two Lengths Between Elbows					
			8"	12"	18"	24"	36"	48"	8" & 48"	12" & 48"	18" & 48"	24" & 48"	36" & 48"	48" & 48"
Secure Temp® ASHT Nova Temp® HT6103+	15°	A	3-5/16" (84mm)	4-5/16" (110mm)	5-7/8" (149mm)	7-7/16" (189mm)	10-1/2" (267mm)	13-5/8" (346mm)	15-3/8" (391mm)	16-7/16" (418mm)	18" (457mm)	19-1/2" (495mm)	22-5/8" (575mm)	25-3/4" (654mm)
		B	15-11/16" (398mm)	19-9/16" (497mm)	25-3/8" (645mm)	31-3/16" (792mm)	42-3/4" (1086mm)	54-3/8" (1381mm)	60-15/16" (1548mm)	64-13/16" (1646mm)	70-9/16" (1792mm)	76-3/8" (1940mm)	87" (2210mm)	99-9/16" (2529mm)
	30°	A	7-7/16" (189mm)	9-7/16" (240mm)	12-7/16" (316mm)	15-7/16" (392mm)	21-7/16" (545mm)	27-7/16" (697mm)	30-13/16" (783mm)	32-13/16" (833mm)	35-13/16" (910mm)	38-13/16" (986mm)	44-13/16" (1138mm)	50-13/16" (1291mm)
		B	20" (508mm)	23-1/2" (597mm)	28-11/16" (729mm)	33-7/8" (860mm)	44-1/4" (1124mm)	54-11/16" (1389mm)	60-9/16" (1538mm)	64" (1627mm)	69-1/4" (1759mm)	74-7/16" (1891mm)	84-13/16" (2154mm)	95-1/4" (2419mm)
45°	A	10-5/16" (262mm)	13-3/16" (335mm)	17-3/8" (441mm)	21-5/8" (549mm)	30-1/8" (765mm)	38-5/8" (981mm)	43-7/16" (113mm)	46-1/4" (1175mm)	50-1/2" (1283mm)	54-3/4" (1391mm)	63-1/4" (1607mm)	71-11/16" (1818mm)	
	B	17-13/16" (452mm)	20-5/8" (524mm)	24-7/8" (632mm)	29-1/8" (740mm)	37-5/8" (956mm)	46-1/8" (1172mm)	50-15/16" (1294mm)	53-3/4" (1365mm)	58" (1473mm)	62-1/4" (1581mm)	70-3/4" (1797mm)	79-3/16" (2011mm)	

Chimney 6" *	Elbow	Offset & Height	One Length Between Elbows						Two Lengths Between Elbows					
			8"	12"	18"	24"	36"	48"	8" & 48"	12" & 48"	18" & 48"	24" & 48"	36" & 48"	48" & 48"
Secure Temp S2100+ Nova Temp HT6000	15°	A	3-5/16" (84mm)	4-5/16" (110mm)	5-7/8" (149mm)	7-7/16" (189mm)	10-1/2" (267mm)	13-5/8" (346mm)	15-1/2" (394mm)	16-1/2" (419mm)	18-1/16" (459mm)	19-5/8" (498mm)	22-3/4" (578mm)	25-13/16" (656mm)
		B	16" (406mm)	19-7/8" (505mm)	25-11/16" (652mm)	31-1/2" (800mm)	43-1/16" (1094mm)	54-5/8" (1387mm)	61-7/16" (1561mm)	65-1/4" (1657mm)	71-1/16" (1805mm)	76-7/8" (1953mm)	88-1/2" (2248mm)	100-1/16" (2542mm)
	30°	A	7-3/8" (187mm)	9-3/8" (238mm)	12-3/8" (314mm)	15-3/8" (391mm)	21-3/8" (543mm)	27-3/8" (695mm)	30-7/8" (784mm)	32-7/8" (835mm)	35-7/8" (911mm)	38-7/8" (987mm)	44-7/8" (1140mm)	50-7/8" (1292mm)
		B	20-11/16" (525mm)	24-3/16" (614mm)	29-3/8" (746mm)	34-9/16" (878mm)	44-15/16" (1141mm)	55-5/16" (1405mm)	61-3/8" (1559mm)	64-7/8" (1648mm)	70-1/16" (1780mm)	75-1/4" (1911mm)	85-5/8" (2175mm)	96" (2438mm)

Chimney 6" *	Elbow	Offset & Height	One Length Between Elbows						Two Lengths Between Elbows					
			---	12"	18"	---	36"	48"	---	12" & 48"	18" & 48"	---	36" & 48"	48" & 48"
AC 6"	15°	A	---	4-13/16" (122 mm)	6-1/8" (156 mm)	---	11" (280 mm)	14-1/8" (359 mm)	---	16-7/8" (429 mm)	18-7/16" (468 mm)	---	23" (584 mm)	26-3/16" (665 mm)
		B	---	27-11/16" (703 mm)	33-1/2" (851 mm)	---	50-7/8" (1292 mm)	62-1/2" (1588 mm)	---	72-5/8" (1845 mm)	78-7/16" (1992 mm)	---	95-3/4" (2432 mm)	107-3/8" (2727 mm)
	30°	A	---	9-3/8" (238 mm)	12-3/8" (314 mm)	---	21-3/8" (543)	27-3/8" (695 mm)	---	32-5/8" (829 mm)	35-5/8" (905 mm)	---	44-5/8" (1134 mm)	50-5/8" (1286 mm)
		B	---	25-3/4" (654 mm)	31" (787 mm)	---	46-1/2" (1181 mm)	57" (1448 mm)	---	66" (1676 mm)	71-1/4" (1810 mm)	---	86-7/8" (2207 mm)	97-1/4" (2740 mm)

NOTE: With the AC chimney*, a starting length of 6" high must be used on top of the fireplace before installing an elbow.

Figure 28

OFFSET CHIMNEY INSTALLATION *

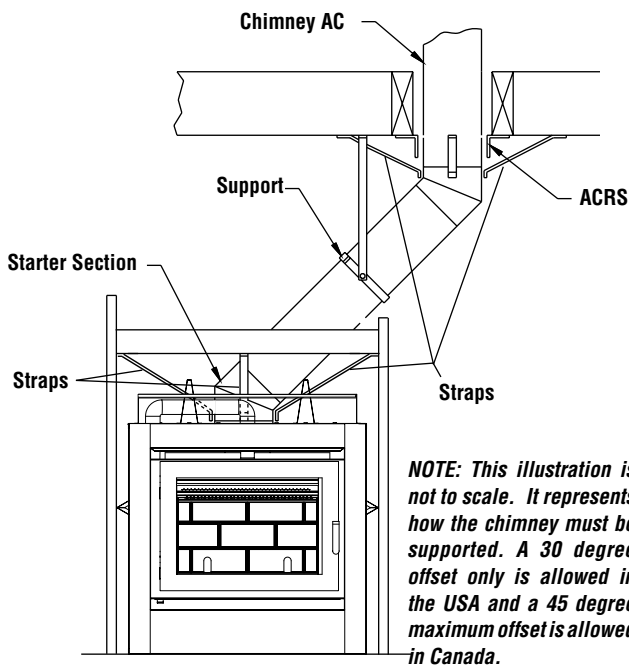

NOTE: This illustration is not to scale. It represents how the chimney must be supported. A 30 degree offset only is allowed in the USA and a 45 degree maximum offset is allowed in Canada.

Figure 29

OFFSET CHIMNEY INSTALLATION WITH WALL PENETRATION*

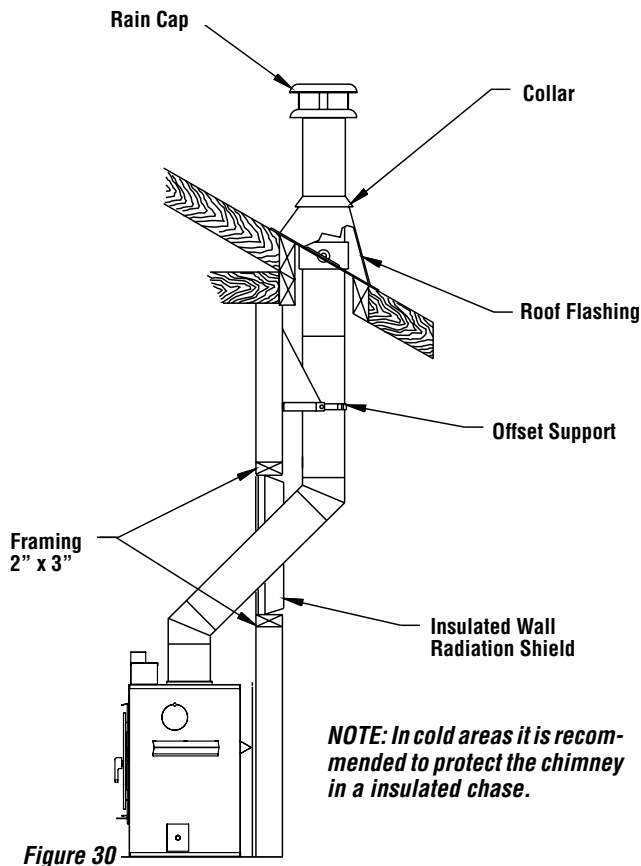

NOTE: In cold areas it is recommended to protect the chimney in a insulated chase.

Figure 30

ANGLED WALL RADIATION SHIELD* (RSM+ and RSMI30)

When traversing a combustible wall with the chimney at a 30° or 45° angle, an angled firestop or wall radiation shield must be installed. Only one is required.

NOTE: 45° angle for Canada only (RSMI45*)

In cold climate locations (climates where temperatures will fall below 32° F / 0° C), we recommend that you use the insulated wall radiation shield since it will maintain the home's thermal barrier.

RSM+ and RSMI30 (RSMI45 - Canada Only)		
Chimney Model*	Angle	Hole Size
ASHT+ / HT6103+ (6" dia). Canada only	30°	283 mm x 781 mm (11-1/8" x 30-3/4")
	45°	283 mm x 518 mm (11-1/8" x 20-3/8")
S-2100+ / HT6000+ / AC (6" dia).	30°	327 mm x 881 mm (12-7/8" x 34-11/16")
	30°	380 mm x 972 mm (15" x 38-1/4")

Table 5

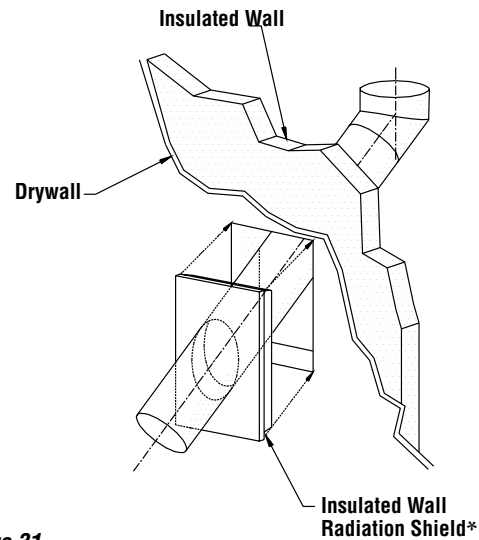

Figure 31

CHIMNEY SUPPORT INSTALLATION

Universal Roof Support*

When installing a support, slightly lift the chimney system so the weight will lie on the support, not on the fireplace to reduce expansion noises. This support has three possible uses:

1. For ASHT+ / HT6103+ and S-2100+ / HT6000+, it must be used on a roof to support the chimney*.
2. It may be used on a floor, ceiling or roof above an offset to support the chimney above the offset.
3. It may be used on a floor, ceiling or roof as a supplementary support.

Table 6 gives maximum height of supported chimney.

NOTE: For the AC chimney*, a support section must be used every forty (40) feet (12 m) instead of the universal roof support (ST*).

For roof support installation, refer to the instructions provided with the support.

Universal Offset Support *

This support is used to support the chimney above an offset. When the chimney offset is used to traverse a wall this support may be used on the wall to support the chimney. The maximum heights are given in **Table 6**. For offset support installation, refer to the instructions provided with the support.

CHIMNEY MODEL*	MAXIMUM HEIGHT OF SUPPORTED CHIMNEY	
	Offset Support	Roof Support
ASHT+ / HT6103+ (6" dia).	28 feet (8.54 m)	29 feet (8.84 m)
S-2100+ / HT6000+ (6" dia).	18 feet (5.49 m)	20 feet (6.1 m)
AC (6" dia).	40 feet (12.19 m)	50 feet (15.20 m)

Table 6

CHIMNEY CHASE AND MULTIPLE TERMINATIONS

For the purpose of this manual, a chimney chase is considered a part of the chimney system rather than part of a building. The termination must be placed a minimum of 18" (460 mm) above the chase.

For installations where more than one chimney is located in the same chase or within the same area, we suggest that their terminations be separated by at least 16" (410 mm) horizontally, and 18" (460 mm) vertically. This separation is to prevent smoke migrating from one chimney to another (see **Figure 32**).

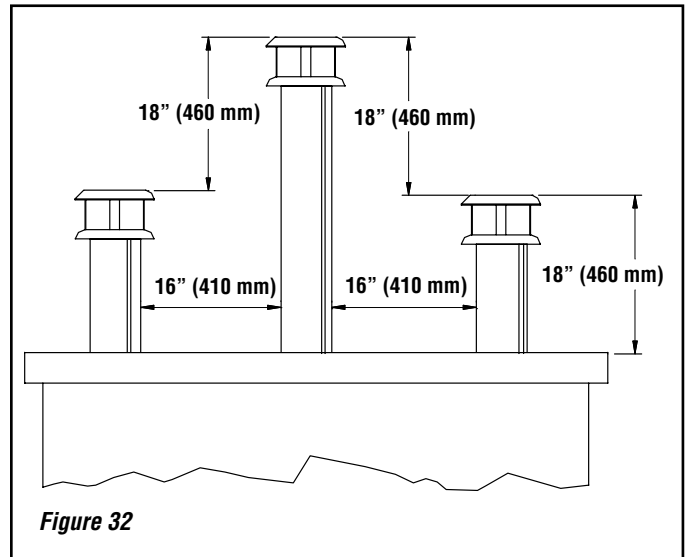

Figure 32

CHIMNEY ADAPTOR* (S-2100+ / HT6000+) CANADA ONLY

The fireplace is supplied with a chimney adaptor suitable for the ASHT+ / HT6103+ chimney*. If you want to install a S-2100+ / HT6000+ chimney, an adaptor is available (6UCA*) (**Figure 33**). A separate starter section will also be required if AC chimney is installed.

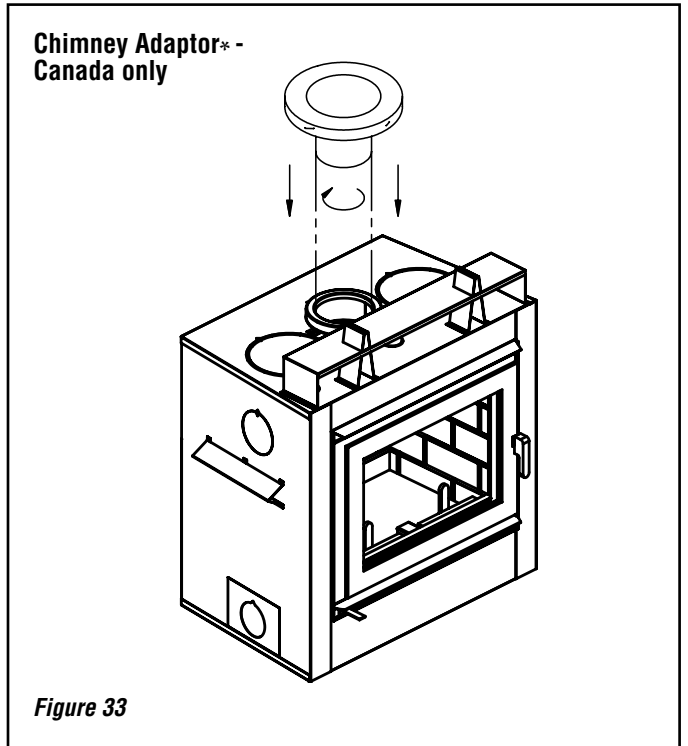

Figure 33

INSTALLATION INSTRUCTIONS FOR MASONRY APPLICATION

WARNING: Before starting the installation, the masonry chimney must be inspected by a qualified chimney sweep.

The following requirements must be respected:

1. The chimney must be absolutely clear of any soot residue or creosote. Check for cracks, loose or missing bricks that could inhibit correct installation of the liner.
2. The clearance to combustibles must be a minimum of 1" between the outside of the masonry and any wood framing or loose insulation.
3. The chimney must be built in accordance with the current building code.
4. No other appliance can be connected to the same chimney.
5. The clearances to combustibles for these fireplace connectors are 2" on the side and bottom and 16" at the top.
6. The connector parts are not necessary if the connection between the insulated length and the stainless steel liner is done within the masonry chimney.

Installation:

The chimney must be relined with a stainless steel liner model Tubinox®* or Projet® SS* of the same diameter as the outlet of the fireplace. If a stainless steel liner is used, see note below**.

For connection at a 45° angle, a special connector (BISUMA*) must be used to connect the liner to the insulated chimney.

*** IMPORTANT NOTE - The use of a 45° connector (BISUMA*) is approved for use in Canada ONLY. Installations in the USA must use the 30° connector (BISUMA30*).**

** Alternate brand rigid stainless liner or stainless flex may be substituted but must be listed to UL-1777 for US application and ULC-S635 for existing masonry or ULC-S640M for new masonry applications in Canada. The steel rigid or flex liner must be rated at 2100° F (1100° C).

Follow these steps:

1. Position the fireplace in its location. Temporarily install the ASHT+* elbow on the top of the fireplace and, using a level, mark with an oval the location where the flue liner will enter the masonry chimney.
2. In the middle of the oval, drill a hole in the masonry chimney at 45°.
3. Increase the size of the hole until a 45° Tubinox* liner elbow can be easily slipped through.
4. Slide the liner down from the top of the masonry chimney until you reach the hole level.
5. Slip through the hole a 45° liner elbow and connect it to the liner.
6. Add a small liner section to the liner elbow which will allow the liner to extend at least 12" (measured at the top of the liner) from the masonry chimney.
7. Seal the opening around the liner with high temperature refractory cement.
8. The next steps must be done in the following order:

See typical installation illustrated below.

- A. Select the ASHT+* length that will fit between the elbow and the liner so that it will slide at least 2" over the liner section (You may need to cut the liner for a better fit).
- B. Take that section and the BISUMA* cover and slide it over the liner. Make sure you have enough opening to be able to install the ASHT+* elbow without difficulty.
- C. Install the 45° elbow on the fireplace.
- D. Slide the length section back down on the elbow and twist lock the two together.
- E. Pull the cover down over the length and install the insulation pad over the liner; be careful to cover the liner completely.
- F. Slide back the cover over the insulation and fix it in place using the 3 metal screws supplied.

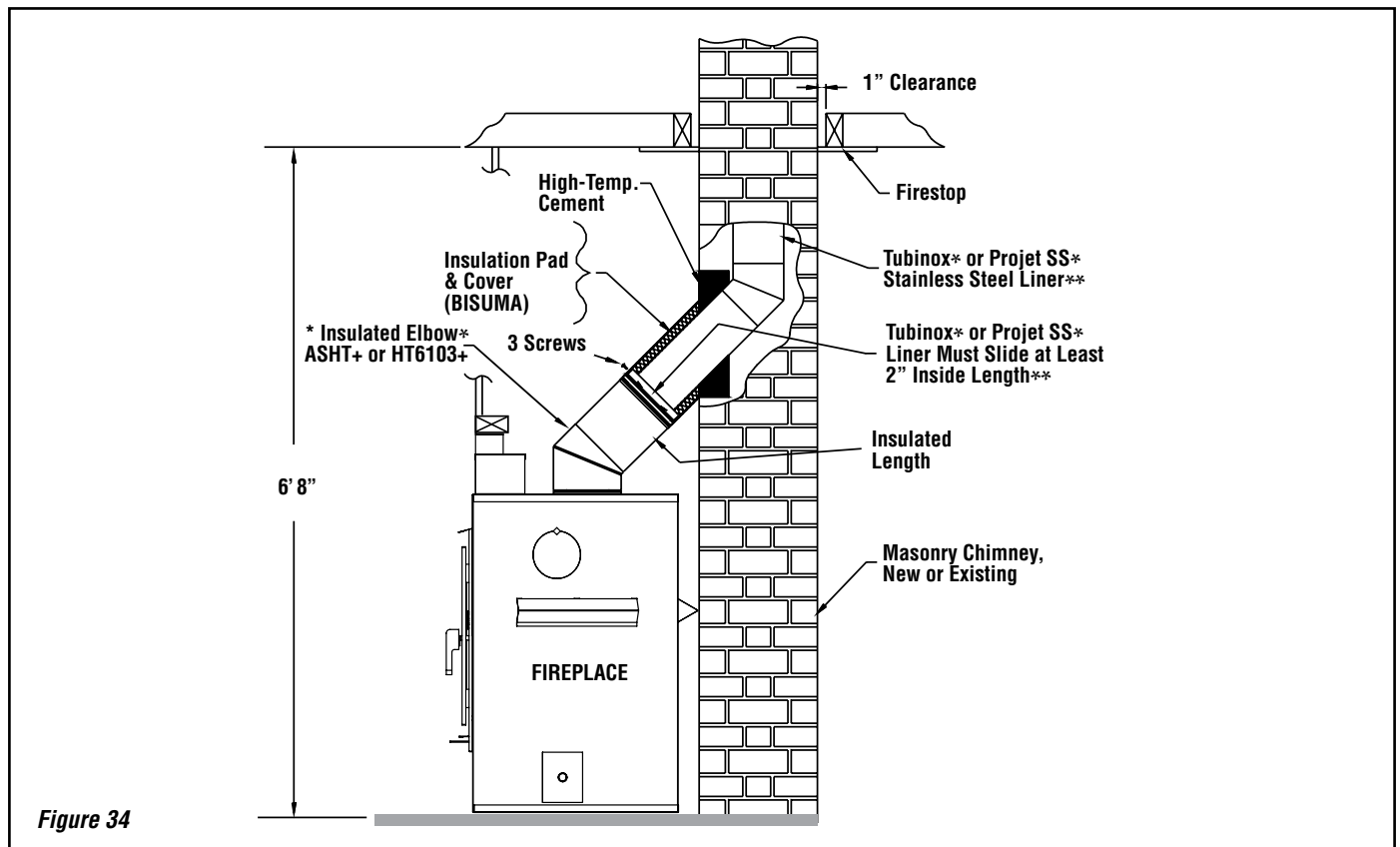

Figure 34

OPTIONAL INSTALLATION ACCESSORIES

Installation Accessories	
Description	Cat./ Part No.
Outside Air Kit	
Outside Air Coupler To Connect Outside Air (UZI) To Fireplace, UZIAD	UZIAD
Outside Air Ducting - includes 4" insulated flex x 10' long, UZI	UZI
Gravity Kit	
Complete double ducting system including: 2 elbows 90°, 2 telescopic lengths, 2 grill supports and 2 black grills. 7B30ZK-1	H8947
Gravity Kit Accessories	
Elbow 90°, 8" dia., 7B26ZE90	H8948
Elbow 45°, 8" dia., 7B26ZE45	H8949
Telescopic length, 8" dia. (15" to 26"), 7B26ZLA	H8950
Adjustable length 8" dia (2" - 5"), 7B26ZL2A	H8951
Length two (2) feet, 8KL2	H8954
Length one (1) feet, 8KL1	H8953
Wall radiation shield, 8" I.D., 7B26ZR	H8952
Fireplace Kits	
Rigid firescreen	BNZN
Central Forced Air Kit Accessories ❶	
Central forced air kit including: blower (BISZY), flex adaptor (BISAF), 2 clamps, variable speed control (VRUW), thermo-disk (VTU), fan to flexible pipe adapter (BISAVF), back draft damper (BISBD), aluminium tape, BISFWK-1	BISFWK-1
Flexible pipe 5" I.D. x 15 ft. Long, 5FLEX15	5FLEX15
Flexible pipe 5" I.D. x 30 ft. Long, 5FLEX25	5FLEX25
Heating and cooling thermostat, 24V, HCTW	HCTW

❶ **Not tested under EPA certification. If installed, this appliance no longer qualifies for EPA certification.**

Cast Surround Kit	
Description	Cat./ Part No.
Cast Surround Kit, WRT3820WS-CSK	F1847
Cast Surround Decorative Keystone, WRT3820WS-CSK-DK	F1848

Fireplace Model WRT3820WS - Approved Venting Components manufactured by Security Chimneys International™ only.

- **6" diameter chimney** - AC (air cooled), Secure Temp® ASHT+ (or Nova Temp® HT6103+) and Secure Temp S-2100+ (or Nova Temp HT6000+).
- **6" diameter chimney for relining masonry chimneys** - Tubinox® chimney (or Projet® SS), 6" diameter with adaptor for installation in a masonry chimney.
- **7" diameter chimney** - Secure Temp ASHT+ (or Nova Temp HT6103+).

REPLACEMENT PARTS LIST

WRT3820WS Replacement Parts	
Description	Part/Cat. No.
Andiron (2 pieces)	PR-SR2875
Bottom refractory	PR-SR2825
Back refractory	PR-SR2826
Left side refractory	PR-SR2828
Right side refractory	PR-SR2827
Front refractory (2 pieces)	PR-SR2829
Secondary air tube (back)	PR-SR2906
Secondary air tube (middle or front)	PR-SR2830
Tube lock (2 pieces)	PR-SR2873
Fireplace left side	PR-SR2848
Fireplace right side	PR-SR2849
Fireplace top	PR-SR2847
Fireplace back	PR-SR2846
Top flex protector	PR-SR2877
Door wooden handle	PR-SR2856
Door locking mechanism	PR-SR2855
Door hinges	PR-SR1933
Ceramic glass	PR-SR2852
Gasket, glass	PR-SR1685H
Gasket, door	PR-SR18230
Blower	PR-UZY6
Door, complete black	PR-SR2851
Door, complete brushed nickel	PR-SR2851BN
Touch-up Paint, Aerosol, Black Metallic	H8159
Blower 250 CFM for central forced air kit, BISZY	BISZY
Blower variable speed control with decorative wall plate for (BISZY), VRUW	VRUW
Thermo-disk, on/off blower control (for BISZY), VTU	VTU
Blower to flexible pipe adaptor, BISAVF	BISAVF
Backdraft damper, BISBD	BISBD
Fireplace to Flex adaptor and 2 clamps, BISAF	BISAF

Contact an IHP dealer to obtain any of these parts. Never use substitute materials not approved by IHP. Use of non-approved parts can result in poor performance and safety hazards.

SPECIFICATIONS

Cat. No.	Model	Description
F1796	WRT3820WS	WRT3820WS, Black

Product Reference Information	
Weight	215 lbs
Height	37-5/8"
Width	32-3/4"
Depth	22-1/2"
Firebox W x H x D - measured in front	19-1/2" x 13-1/4" x 12"
Chimney Weight ASHT (6" dia)	6.25 lb per linear foot
Chimney Weight AC (6" dia.)	3.25 lb per linear foot
Chimney weight S-2100+ (6" dia.)	10.8 lb per linear foot

CLEARANCE TO COMBUSTIBLES

The following clearances meet the minimum requirements for a safe installation;

Side wall: 17" (324 mm) measured from the fireplace side

Ceiling: 6' 8" (2,032 mm) measured from the base of the fireplace

Fireplace enclosure:

Bottom: 0"

Side: 0" to spacer

Back: 0" to spacer

Top: Do not fill the space above the fireplace with any material (Except the wood framing. See **Page 10, Figure 8**)

Chimney: 2" (50mm)

Mantel: 39" (990mm) measured from the base of the fireplace.

SECURITY CHIMNEYS™ - PARTS AND COMPONENTS LISTS

The components listed below must be ordered from Security Chimneys International™. Contact your Security Chimneys Distributor or Dealer for ordering information.

Security Chimneys International Limited 450-973-9999
 2125 Monterey, Laval, Quebec 1-800-361-4909 (USA)
 Canada, H7L 3T6 1-800-667-3387 (Canada)
 securitychimneys.com

Secure Temp® ASHT 1" High Temp. Insulated Stainless Steel Chimney 6" I.D. and 8" O.D., Double-Wall Stainl. Steel, Listed to CAN/UCL-S604 and UL-103HT	
Description	Part/Cat. No.
Lengths and Misc. Chimney Components	
8" length, 6" Dia., 6L8	6L8
12" length, 6" Dia., 6L12	6L12
18" length, 6" Dia., 6L18	6L18
24" length, 6" Dia., 6L24	6L24
36" length, 6" Dia., 6L36	6L36
48" length, 6" Dia., 6L48	6L48
Adjustable Length 12", 6" Dia., 6LA	6LA
15° elbow, 6" Dia., 6E15	6E15
30° elbow, 6" Dia., 6E30	6E30
Rain Termination Cap, 6" Dia., 6CC	6CC
Spark Arrester Screen (universal spark arrester band), PE	PE
Wall Band, BM	BM
Supports	
Offset Support, SO	SO
Roof Support, ST	ST
Roof Brace, BS2	BS2
Firestops	
Firestop, 6BF	6BF
Radiation Shield, 6RS	6RS
Insulated Attic Radiation Shield, 6RSA2	6RSA2
Insulated Wall Radiation Shield, 6RSM	6RSM
Insulated Wall Radiation Shield, 30°, 6RSMI30	6RSMI30
Uninsulated Wall Radiation Shield, 30°, 6RSM30	6RSM30
Attic Radiation Shield	H0487
Roof Flashings	
Flat Roof Flashing, 6FR	6FR
1/12 - 7/12 (5° - 30°), 6FAR	6FAR
8/12 - 12/12 (30° - 45°), 6FBR	6FBR
Storm Collar, 6FC	6FC
Chimney Adaptors	
Chimney Adaptor, 6" (S2100, HT6000)	6UCA
Chimney Adaptor, 6 to 7" (ASHT, HT6103)	6AW7

NOTES:

- ① Nova Temp HT6000+ is equivalent to Secure Temp S-2100+
- ② Nova Temp HT6103+ is equivalent to Secure Temp ASHT+
- ③ This appliance is equipped with the ASHT Chimney Adaptor. When other chimney is used, a chimney adaptor for that chimney will be required.
- ④ Chimney Adaptor (S-2100+ / HT6000+) for CANADA ONLY - If you want to install a S-2100+ / HT6000+ chimney, an adaptor is available (6UCA).
- ⑤ AC Chimney is NOT recommended at elevations above 4,000 feet or in cold climates (climates where temperatures will fall below 32° F / 0° C). When using AC chimney, an AC6SB starter section must be used before installing an elbow. When an offset is needed immediately off the top of the fireplace, an elbow starter section (AC6SB30) is available.
- ⑥ Chimney Adaptor 7in - If you want to install a 7in ASHT / HT6103 chimney, an adaptor is available (6AW7).

(AC) Air-Cooled Chimney System*	
6" I.D. and 11" O.D. Air Cooled, Stainl. Steel inner and zinc coated steel exterior	
<i>* AC Chimney is NOT recommended at elevations above 4,000 feet or in cold climates (climates where temperatures will fall below 32° F / 0° C).</i>	
Description	Cat./Part No.
One of the following adaptors is required if installing an AC chimney system	
Starter Section (adaptor), 6", AC, AC6SB	H3779
Starter 30° Elbow, 6" AC, AC6SB30	H3780
The following outside air kit is required if installing an AC chimney system	
Chimney Outside Air Kit (flex, insulation, outside register and coupling), ACZI	H1967
Lengths and Misc. Chimney Components	
12" Length, 6" Dia., AC6L12	H0472
18" Length, 6" Dia., AC6L18	H0473
36" Length, 6" Dia., AC6L36	H0474
48" Length, 6" Dia., AC6L48	H0475
15° Elbow, 6" Dia., AC6E15	H0476
30° Elbow, 6" Dia., AC6E30	H0477
Rain Termination Cap, 6" Dia., AC6CPR	H0478
Spark Arrester Screen (universal spark arrester band), PE	PE
Wall Band, XBM	XBM
Supports	
Offset Support, SO	SO
Support Section, AC6SL	H0481
Roof Support, ST	ST
Roof Brace, BS2	BS2
Roof Flashings	
Flat Roof Flashing, ACF	H0494
1/12 - 7/12 (5° - 30°), AC Adj. Roof Flashing, FA	H0495
8/12 - 12/12 (30° - 45°), AC Adj. Roof Flashing, FB	H0496
Storm collar, ACFC	H0500
Misc.	
Telescopic attic radiation shield, ACRST	H0498
Firestop, ACBF	H0485
Radiation Shield, ACRS	H0486
Attic Radiation Shield, ACRSA	H0487
Insulated Wall Radiation Shield, 30°, ACRSMI30	H0489

Gravity Kit Accessories	
Elbow 90°, 8" dia., 7B26ZE90	7B26ZE90
Elbow 45°, 8" dia., 7B26ZE45	7B26ZE45
Telescopic length, 8" dia. (15" to 26"), 7B26ZLA	7B26ZLA
Adjustable length 8" dia (2" - 5"), 7B26ZL2A	7B26ZL2A
Wall radiation shield, 8" I.D., 7B26ZR	7B26ZR
Black grill with support, 7B30ZO	7B30ZO
Brass grill (for 7B30ZK), 7B30ZGB	7B30ZGB
Length one (1) feet, 8KL1	8KL1
Length two (2) feet, 8KL2	8KL2
Length three (3) feet, 8KL3	8KL3
Length four (4) feet, 8KL4	8KL4
Length five (5) feet, 8KL5	8KL5

NOTE: DIAGRAMS & ILLUSTRATIONS ARE NOT TO SCALE.

SECURITY CHIMNEYS™ - PARTS AND COMPONENTS LISTS

The components listed below must be ordered from Security Chimneys International™. Contact your Security Chimneys Distributor or Dealer for ordering information.

Security Chimneys International Limited 450-973-9999
 2125 Monterey, Laval, Quebec 1-800-361-4909 (USA)
 Canada, H7L 3T6 1-800-667-3387 (Canada)
 securitychimneys.com

Tubinox® LL Chimney Lining System**	
Rigid Stainless Steel Liner For Relining A Masonry Chimney, 6" Diameter Listed to ULC-S635M, UL-1777 and ULC-S640M at 2100° F	
Description	Cat./Part No.
6" Length, 6" Dia., 6LL6	6LL6
12" Length, 6" Dia., 6LL12	6LL12
24" Length, 6" Dia., 6LL24	6LL24
36" Length, 6" Dia., 6LL36	6LL36
48" Length, 6" Dia., 6LL48	6LL48
Adjustable Length (7" to 11"), 6" Dia., 6L7A	6L7A
Split Base Tee, 6" Dia., 6LT	6LT
Tee Cap, 6" Dia., 6TCS	6TCS
Twist Lock Tee Cap, 6" Dia., 6LTC	6LTC
Elbow 30°, 6" Dia., 6LE30	6LE30
Elbow 45°, 6" Dia., 6LE45	6LE45
Elbow 90°, 6" Dia., 6LE90	6LE90
Rain Termination Cap (regular), 6" Dia., 6LCS	6LCS
Rain Termination Cap (deluxe), 6" Dia., 6LCC	6LCC
Supports	
Top Support, 6LST	6LST
Support Assembly, 6LSA	6LSA
Interior Support, 6LSB	6LSB
Adaptor Flexible Pipe (male), 6LAAM	6LAAM
Adaptor Flexible Pipe (female), 6LAAF	6LAAF
Stainless Steel Flex - five (5) feet Long, 6LLFLEX	6LLFLEX
Adjustable Insulated Wall Radiation Shield 6" - 12", 6LRSMI	6LRSMI
Adaptors to Masonry Chimney	
Masonry Chimney Adaptor, 45°, BISUMA (for use with Tubinox liner) CANADA ONLY	BISUMA
Masonry Chimney Adaptor, 30°, BISUMA30 (for use with Tubinox liner)	BISUMA30

Gravity Kit Accessories	
Elbow 90°, 8" dia., 7B26ZE90	7B26ZE90
Elbow 45°, 8" dia., 7B26ZE45	7B26ZE45
Telescopic length, 8" dia. (15" to 26"), 7B26ZLA	7B26ZLA
Adjustable length 8" dia (2" - 5"), 7B26ZL2A	7B26ZL2A
Wall radiation shield, 8" I.D., 7B26ZR	7B26ZR
Black grill with support, 7B30ZO	7B30ZO
Brass grill (for 7B30ZK), 7B30ZGB	7B30ZGB
Length one (1) feet, 8KL1	8KL1
Length two (2) feet, 8KL2	8KL2
Length three (3) feet, 8KL3	8KL3
Length four (4) feet, 8KL4	8KL4
Length five (5) feet, 8KL5	8KL5

** Alternate brand rigid stainless liner or stainless flex may be substituted but must be listed to UL-1777 for US application and ULC-S635 for existing masonry or ULC-S640M for new masonry applications in Canada. The steel rigid or flex liner must be rated at 2100° F (1100° C).

NOTES

Innovative Hearth Products Superior™ Brand Wood-Burning Fireplace 20 Year Limited Warranty

THE WARRANTY

Innovative Hearth Products ("IHP") 20 Year Limited Warranty warrants your Superior™ Brand wood burning fireplace ("Product") to be free from defects in materials and workmanship at the time of manufacture. The Product body, firebox and ceramic glass carry the 20 Year Limited Warranty. Ceramic glass carries the 20 Year Limited Warranty against thermal breakage only. After installation, if covered components manufactured by IHP are found to be defective in materials or workmanship during the 20 Year Limited Warranty period and while the Product remains at the site of the original installation, IHP will, at its option, repair or replace the covered components. If repair or replacement is not commercially practical, IHP will, at its option, refund the purchase price or wholesale price of the IHP product, whichever is applicable. IHP will also pay IHP prevailing labor rates, as determined in its sole discretion, incurred in repairing or replacing such components for up to five years. THERE ARE EXCLUSIONS AND LIMITATIONS to this 20 Year Limited Warranty as described herein.

COVERAGE COMMENCEMENT DATE

Warranty coverage begins on the date of installation. In the case of new home construction, warranty coverage begins on the date of first occupancy of the dwelling or six months after the sale of the Product by an independent IHP dealer/distributor, whichever occurs earlier. The warranty shall commence no later than 24 months following the date of product shipment from IHP, regardless of the installation or occupancy date.

EXCLUSIONS AND LIMITATIONS

This 20 Year Limited Warranty applies only if the Product is installed in the United States or Canada and only if operated and maintained in accordance with the printed instructions accompanying the Product and in compliance with all applicable installation and building codes and good trade practices.

This warranty is non-transferable and extends to the original owner only. The Product must be purchased through a listed supplier of IHP and proof of purchase must be provided. The Product body and firebox carry the 20 Year Limited Warranty from the date of installation. Vent components, trim components, paint and applied stains are excluded from this 20 Year Limited Warranty. The following do not carry a 20 Year Limited Warranty but are warranted as follows:

Air tubes, baffles and brick retainers – Repair or replacement for one year from the date of installation

Cast iron parts – Replacement for one year from date of installation

Catalyst – Carries a separate warranty. Refer to the warranty certificate provided for that part

Electrical components – Repair or replacement for one year from the date of installation

Fireplace screens, refractory and side shields (metal or refractory) – Repair or replacement for two years from date of installation. Excludes hairline cracks.

Fuel grates – These parts are considered consumable accessories and therefore are not warranted, with the exception of defects in material or workmanship which are covered for 90 days from the date of installation

Gaskets – Replacement for one year from date of installation

Gold & nickel plating – Replacement for two years from date of installation. Excludes tarnishing

Optional glass doors – Repair or replacement for 90 days from the date of installation

Refractory & screens – Replacement for two years from date of installation. Excludes hairline cracks

Removable air tubes – Repair or replacement for seven years from date of installation. IHP prevailing labor rates for years one through five.

Labor coverage – Prevailing IHP labor rates apply for the warranty period of the component.

Parts not otherwise listed carry a 90 day warranty from the date of installation.

Whenever practicable, IHP will provide replacement parts, if available, for a period of 10 years from the last date of manufacture of the Product.

IHP will not be responsible for: (a) damages caused by normal wear and tear, accident, riot, fire, flood or acts of God; (b) damages caused by abuse, negligence, misuse, or unauthorized alteration or repair of the Product affecting its stability or performance. (The Product must be subject to normal use with approved fuels listed in the Operation Manual provided with the product. This includes burning such fireplace fuels as wood and natural or propane gas. Fuel products with abnormal burning characteristics, including but not limited to fuel such as driftwood, coal or plywood and wood products using a binder may burn at excessive temperatures and may cause damage to the Product or may cause it to function improperly.); (c) damages caused by failing to provide proper maintenance and service in accordance with the instructions provided with the Product; (d) damages, repairs or inefficiency resulting from faulty installation or application of the Product.

Coverage of this 20 Year Limited Warranty is conditional upon use of an adequate fuel grate on factory-built fireplaces only, when applicable.

IHP is not responsible for inadequate fireplace system draft caused by air conditioning and heating systems, mechanical ventilation systems, or general construction conditions which may generate negative air pressure in the room in which the appliance is installed. Additionally IHP assumes no responsibility for smoking conditions caused by inadequate chimney height, adjoining trees or buildings, adverse wind conditions or unusual environmental factors and conditions. Certain IHP Products are listed for use with Security Chimneys International, Ltd. or IHP chimney systems only. Use of chimney components other than that specified in the Product manual will void the Product warranty.

This 20 Year Limited Warranty covers only parts and labor as provided herein. In no case shall IHP be responsible for materials, components or construction which are not manufactured or supplied by IHP or for the labor necessary to install, repair or remove such materials, components or construction. Additional utility bills incurred due to any malfunction or defect in equipment are not covered by this 20 Year Limited Warranty. All replacement or repair components will be shipped F.O.B. from the nearest stocking IHP factory.

LIMITATION ON LIABILITY

It is expressly agreed and understood that IHP's sole obligation and the purchaser's exclusive remedy under this warranty, under any other warranty, expressed or implied, or in contract, tort or otherwise, shall be limited to replacement, repair, or refund, as specified herein.

In no event shall IHP be liable for any incidental or consequential damages caused by defects in the Product, whether such damage occurs or is discovered before or after replacement or repair, and whether such damage is caused by IHP's negligence. IHP has not made and does not make any representation or warranty of fitness for a particular use or purpose, and there is no implied condition of fitness for a particular use or purpose.

IHP makes no expressed warranties except as stated in this 20 Year Limited Warranty. The duration of any implied warranty is limited to the duration of this expressed warranty.

No one is authorized to change this 20 Year Limited Warranty or to create for IHP any other obligation or liability in connection with the Product. Some states and provinces do not allow the exclusion or limitation of incidental or consequential damages, so the above limitations or exclusions may not apply to you. The provisions of this 20 Year Limited Warranty are in addition to and not a modification of or subtraction from any statutory warranties and other rights and remedies provided by law.

INVESTIGATION OF CLAIMS AGAINST WARRANTY

IHP reserves the right to investigate any and all claims against this 20 Year Limited Warranty and to decide, in its sole discretion, upon the method of settlement.

To receive the benefits and advantages described in this 20 Year Limited Warranty, the appliance must be installed and repaired by a licensed contractor approved by IHP.

Contact IHP at the address provided herein to obtain a listing of approved dealers/distributors. **IHP shall in no event be responsible for any warranty work done by a contractor that is not approved without first obtaining IHP's prior written consent.**

HOW TO REGISTER A CLAIM AGAINST WARRANTY

In order for any claim under this warranty to be valid, you must contact the IHP dealer/distributor from which you purchased the product. If you cannot locate the dealer/distributor, then you must notify IHP in writing. IHP must be notified of the claimed defect in writing within 90 days of the date of failure. Notices should be directed to the IHP Warranty Department at 1508 Elm Hill Pike, Suite 108; Nashville, TN 37210 or visit our website at WWW.SUPERIORFIREPLACES.US.COM.

WARRANTY

Your fireplace is covered by a limited warranty. Please read the warranty to be familiar with its coverage.

Retain this manual. File it with your other documents for future reference.

PRODUCT REFERENCE INFORMATION

We recommend that you record the following important information about your fireplace. Please contact your IHP dealer for any questions or concerns.

REPLACEMENT PARTS

See **Page 23** for a complete replacement parts list. Use only parts supplied from the manufacturer.

Normally, all parts should be ordered through your IHP distributor or dealer. Parts will be shipped at prevailing prices at time of order.

When ordering repair parts, always give the following information:

1. The model number of the appliance.
2. The serial number of the appliance.
3. The part number.
4. The description of the part.
5. The quantity required.
6. The installation date of the appliance.

If you encounter any problems or have any questions concerning the installation or application of this system, please contact your dealer.

IHP
1508 Elm Hill Pike, Suite 108
Nashville, TN 37210
Visit us at SuperiorFireplaces.us.com

Model Number _____
Serial Number _____
Date Installed _____
Dealer's Name _____
Dealer's Phone Number _____



NATIONAL FIREPLACE INSTITUTE
NFI
CERTIFIED
www.nficertified.org

We recommend that our woodburning hearth products be installed and serviced by professionals who are certified in the U.S. by the National Fireplace Institute® (NFI) as NFI Woodburning Specialists or who are certified in Canada by Wood Energy Technical Training (WETT).



Wood Energy Technical Training
www.wettinc.ca

IHP reserves the right to make changes at any time, without notice, in design, materials, specifications, and prices, and also to discontinue colors, styles, and products. Consult your local distributor for fireplace code information.

