

INSTALLATION INSTRUCTIONS AND OWNER'S MANUAL

INSTALLER: Leave this manual with the appliance.
CONSUMER: Retain this manual for future reference.

WARNING: If not installed, operated and maintained in accordance with the manufacturer's instructions, this product could expose you to substances in fuel or from fuel combustion which can cause death or serious illness.

⚠ WARNING

FIRE OR EXPLOSION HAZARD

Failure to follow safety warnings exactly could result in serious injury, death or property damage.

- Do not store or use gasoline or other flammable vapors and liquids in the vicinity of this or any other appliance.
- **WHAT TO DO IF YOU SMELL GAS**
 - Do not try to light any appliance.
 - Do not touch any electrical switch; do not use any phone in your building.
 - Leave the building immediately.
 - Immediately call your gas supplier from a neighbor's phone. Follow the gas supplier's instructions.
 - If you cannot reach your gas supplier, call the fire department.
- Installation and service must be performed by a qualified installer, service agency or the gas supplier.

B-VENT ZERO CLEARANCE GAS FIREPLACE

MILLIVOLT MODELS:

BVD34FP30(F,L)N-2
BVD36FP3(0,2)(F,L)N-1
BVP42FP30(F,L)N-1
BVP42FP32(F,L)N-3

DIRECT IGNITION MODELS:

BVD34FP50(F,L)N-2
BVD36FP5(0,2)(F,L)N-1
BVP42FP50(F,L)N-1
BVP42FP52(F,L)N-3



UL FILE NO. MH45034

NOT INTENDED FOR USE AS A PRIMARY HEAT SOURCE. This appliance is tested and approved as either supplemental room heat or as a decorative appliance. It should not be factored as primary heat in residential heating calculations.

This appliance is only for use with the type of gas indicated on the rating plate. This appliance is not convertible for use with other gases, unless a certified kit is used.

⚠ WARNING



**HOT GLASS WILL
CAUSE BURNS.
DO NOT TOUCH GLASS
UNTIL COOLED.
NEVER ALLOW CHILDREN
TO TOUCH GLASS.**

A barrier designed to reduce the risk of burns from the hot viewing glass is provided with this appliance and shall be installed for the protection of children and other at-risk individuals.

**NATIONAL
FIREPLACE
INSTITUTE**



CERTIFIED
www.nficertified.org

We suggest that our gas hearth products be installed and serviced by professionals who are certified in the U.S. by the National Fireplace Institute® (NFI) as NFI Gas Specialists.

TABLE OF CONTENTS

Section	Page
Important Safety Information.....	3
Safety Information for Users of LP Gas	4
Introduction	5
Specifications	6
Fireplace Dimensions.....	6
Clearances	7
Locating Fireplace.....	7
Gas Supply.....	8-9
Installation	10-11
Venting	12-13
Log Placement (BVD34 and BVD36) (5 Log Set)	14
Log Placement (BVP42) (4 Log Set).....	15
Operating Instructions	16-17
Standing Pilot Wiring Diagram	18
Standing Pilot Lighting Instructions	19
Standing Pilot Troubleshooting	20
Standing Pilot Propane/LP Gas Conversion	21-22
Direct Ignition Wiring Diagram	23
Optional Remote Control (120V Direct Ignition).....	23
Direct Ignition Lighting Instructions	24
Direct Ignition Troubleshooting.....	25
Direct Ignition Propane/LP Gas Conversion	25-26
Maintenance and Service.....	27
BVD34 and BVD36 Parts List	28
BVD34 and BVD36 Parts View	29
BVP42 Parts List.....	30
BVP42 Parts View	31
FBB4 Optional Variable Speed Blower Installation Instructions.....	32-33
Junction Box Wiring Installation Instructions.....	34
Barrier Screens	35
Optional Accessories.....	35
Decorative Accessories.....	36
Master Parts Distributor List.....	37
How To Order Repair Parts	37
Quick Reference Guide.....	38-39

IMPORTANT SAFETY INFORMATION

Before enclosing the vent pipe assembly, operate the appliance to ensure it is venting properly.

- If this appliance is installed directly on carpeting, tile or other combustible material other than wood flooring the appliance shall be installed on a metal or wood panel extending the full width and depth of the appliance.

The base referred to above does not mean the fireproof base as used on wood stoves. The protection is for rugs that are extremely thick and light colored tile.

- Children and adults should be alerted to the hazards of high surface temperatures and should stay away to avoid burns or clothing ignition.
- Young children should be carefully supervised when they are in the same room as the appliance.
- Clothing or other flammable material should not be placed on or near the appliance.
- Adequate accessibility clearances for servicing and proper operation.
- This appliance must not share or be connected to a flue serving a separate solid-fuel burning appliance.
- Keep the area around your appliance clear of combustible materials, gasoline and other flammable vapor and liquids.
- Under no circumstances should any solid fuels (wood, coal, paper or cardboard etc.) be used in this appliance.
- The flow of combustion and ventilation air must not be obstructed in any way.
- Young children should be carefully supervised when they are in the same room as the appliance. Toddlers, young children, and others may be susceptible to accidental contact burns. A physical barrier is recommended if there are at-risk individuals in the house. To restrict access to a fireplace or stove, install an adjustable safety gate to keep toddlers young children, and other at-risk individuals out of the room and away from hot surfaces.
- If the barrier becomes damaged, the barrier shall be replaced with the manufacturer's barrier for this appliance.
- Any safety screen, guard, or barrier removed for servicing an appliance must be replaced prior to operating the appliance.
- If optional glass bifold doors are installed, the fireplace must be operated with the doors in the fully open position.

- Due to high temperatures the appliance should be located out of traffic and away from furniture and draperies.
- Any part removed for servicing the appliance must be replaced prior to operating the appliance. Work should be done by a qualified service person.
- Keep burner and control compartment clean.
- Vent cap is hot while fireplace is in operation.
- Installation and repair should be done by a **QUALIFIED SERVICE PERSON**. The appliance should be inspected before use and at least annually by a qualified service person. More frequent cleaning may be required due to excessive lint from carpeting, bedding materials, etc. It is imperative that control compartments, burners and circulating air passageways of the appliance be kept clean.
- **DO NOT** put anything around the fireplace that will obstruct the flow of ventilation air.
- Clearance in accordance with local installation codes and the requirements of the gas supplier.
- **DO** keep the appliance area clear and free from combustible material, gasoline and other flammable vapors and liquids.
- **DO** examine venting system periodically and replace damaged parts.
- **DO** make a periodic visual check of pilot and burners. Clean and replace damaged parts.
- **DO NOT** use this fireplace if any part has been under water. Immediately call a qualified service technician to inspect the heater and to replace any part of the control system and any gas control which has been under water.
- Any safety screen, guard or barrier removed for servicing an appliance must be replaced prior to operating the appliance.
- **ONLY** doors certified with the appliance shall be used.

SAFETY INFORMATION FOR USERS OF LP-GAS

Propane (LP-Gas) is a flammable gas which can cause fires and explosions. In its natural state, propane is odorless and colorless. You may not know all the following safety precautions which can protect both you and your family from an accident. Read them carefully now, then review them point by point with the members of your household. Someday when there may not be a minute to lose, everyone's safety will depend on knowing exactly what to do. If, after reading the following information, you feel you still need more information, please contact your gas supplier.

LP-GAS WARNING ODOR

If a gas leak happens, you should be able to smell the gas because of the odorant put in the LP-Gas. That's your signal to go into immediate action!

- Do not operate electric switches, light matches, use your phone. Do not do anything that could ignite the gas.
- Get everyone out of the building, vehicle, trailer, or area. Do that IMMEDIATELY.
- Close all gas tank or cylinder supply valves.
- LP-Gas is heavier than air and may settle in low areas such as basements. When you have reason to suspect a gas leak, keep out of basements and other low areas. Stay out until firefighters declare them to be safe.
- Use your neighbor's phone and call a trained LP-Gas service person and the fire department. Even though you may not continue to smell gas, do not turn on the gas again. Do not re-enter the building, vehicle, trailer, or area.
- **Finally**, let the service man and firefighters check for escaped gas. Have them air out the area before you return. Properly trained LP-Gas service people should repair the leak, then check and relight the gas appliance for you.

NO ODOR DETECTED - ODOR FADE

Some people cannot smell well. Some people cannot smell the odor of the chemical put into the gas. You must find out if you can smell the odorant in propane. Smoking can decrease your ability to smell. Being around an odor for a time can affect your sensitivity or ability to detect that odor. Sometimes other odors in the area mask the gas odor. People may not smell the gas odor or their minds are on something else. Thinking about smelling a gas odor can make it easier to smell.

The odorant in LP-gas is colorless, and it can fade under some circumstances. For example, if there is an underground leak, the movement of the gas through soil can filter the odorant. Odorants in LP-Gas also are subject to oxidation. This fading can occur if there is rust inside the storage tank or in iron gas pipes.

The odorant in escaped gas can adsorb or absorb onto or into walls, masonry and other materials and fabrics in a room. That will take some of the odorant out of the gas, reducing its odor intensity.

LP-Gas may stratify in a closed area, and the odor intensity could vary at different levels. Since it is heavier than air, there may be more odor at lower levels. Always be sensitive to the slightest gas odor. If you detect any odor, treat it as a serious leak. Immediately go into action as instructed earlier.

SOME POINTS TO REMEMBER

- Learn to recognize the odor of LP-gas. Your local LP-Gas Dealer can give you a "Scratch and Sniff" pamphlet. Use it to find out what the propane odor smells like. If you suspect that your LP-Gas has a weak or abnormal odor, call your LP-Gas Dealer.
- If you are not qualified, do not light pilot lights, perform service, or make adjustments to appliances on the LP-Gas system. If you are qualified, consciously think about the odor of LP-Gas prior to and while lighting pilot lights or performing service or making adjustments.
- Sometimes a basement or a closed-up house has a musty smell that can cover up the LP-Gas odor. Do not try to light pilot lights, perform service, or make adjustments in an area where the conditions are such that you may not detect the odor if there has been a leak of LP-Gas.
- Odor fade, due to oxidation by rust or adsorption on walls of new cylinders and tanks, is possible. Therefore, people should be particularly alert and careful when new tanks or cylinders are placed in service. Odor fade can occur in new tanks, or reinstalled old tanks, if they are filled and allowed to set too long before refilling. Cylinders and tanks which have been out of service for a time may develop internal rust which will cause odor fade. If such conditions are suspected to exist, a periodic sniff test of the gas is advisable. **If you have any question about the gas odor, call your LP-gas dealer. A periodic sniff test of the LP-gas is a good safety measure under any condition.**
- If, at any time, you do not smell the LP-Gas odorant and you think you should, assume you have a leak. Then take the same immediate action recommended above for the occasion when you do detect the odorized LP-Gas.
- If you experience a complete "gas out," (the container is under no vapor pressure), turn the tank valve off immediately. If the container valve is left on, the container may draw in some air through openings such as pilot light orifices. If this occurs, some new internal rusting could occur. If the valve is left open, then treat the container as a new tank. Always be sure your container is under vapor pressure by turning it off at the container before it goes completely empty or having it refilled before it is completely empty.

INTRODUCTION

Instructions to Installer

1. Installer must leave instruction manual with owner after installation.
2. Installer must have owner fill out and mail warranty card supplied with the fireplace.
3. Installer should show owner how to start and operate the fireplace. This is a B-Vent gas appliance and must be installed with a listed B-Vent vent system. The information contained in this manual pertains to all models and gas control systems unless otherwise noted.

Warning: This unit is not for use with solid fuels.

Appliance Certification

This fireplace is design certified in accordance with American National Standard/CSA Standard ANSI Z.21-50/CSA 2.22 and by Underwriters Laboratories as a Vented Gas Appliance and shall be installed according to these instructions.

Consult your local building code agency, prior to installation, to ensure compliance with local codes-including permits and inspections.

The fireplace, when installed, must be electrically grounded in accordance with local codes or, in absence of local codes, with the *National Electric Code ANSI/NFPA 70* if an external electrical source is utilized.

These models may be installed in a bedroom or bed-sitting room in the U.S.A.

Qualified Installing Agency

Installation and replacement of gas piping, gas utilization equipment or accessories and repair and servicing of equipment shall be performed only by a qualified agency. The term "qualified agency" means any individual, firm, corporation or company which either in person or through a representative is engaged in and is responsible for (a) the installation or replacement of gas piping or (b) the connection, installation, repair or servicing of equipment, who is experienced in such work, familiar with all precautions required and has complied with all the requirements of the authority having jurisdiction.

The installation must conform with local codes or, in the absence of local codes, with the *National Fuel Gas Code ANSI Z223.1/NFPA 54** *Natural Gas and Propane Installation Code*, or *CSA B149.1 in Canada*. *Available from the American National Standards Institute, Inc. 11 West 42nd St., New York, N.Y. 10036.

State of Massachusetts: The installation must be made by a licensed plumber or gas fitter in the Commonwealth of Massachusetts. The state of Massachusetts requires that a flexible appliance connector cannot exceed three feet in length.

Any alteration of the original design, installed other than as shown in these instructions or use with a type of gas not shown on the rating plate is the responsibility of the person and company making the change.

Warning: ANY CHANGE TO THIS FIREPLACE OR ITS CONTROLS CAN BE DANGEROUS.

Improper installation or use of the fireplace can cause serious injury or death from fire, burns, explosions, or carbon monoxide poisoning.

Important

All correspondence should refer to complete Model Number, Serial Number and type of gas.

High Altitude

When installing this unit at an elevation above 2000 feet (in the United States) it may be necessary to decrease the input rating by changing the existing burner orifice to a smaller size. Generally, input should be reduced 4 percent for each 1000 feet above sea level. However, if the heating value of the gas has been reduced, this general rule may not apply. Check with local gas utility for proper orifice size identification.

Canadian High Altitude

Altitude: 0-4500 feet (0-1370 m)

When installing this unit at an elevation above 4500 feet (in Canada), check with local authorities.

Consult your local gas utility for assistance in determining the proper orifice for location.

Preparation

This gas fireplace and its components are tested and safe when installed in accordance with this Installation Manual. Report to your dealer any parts damaged in shipment, specifically check glass condition. Do not install unit with damaged, incomplete, or substitute parts. Read all instructions before starting installation and follow these instructions carefully during installation to insure maximum benefit and safety. Failure to follow them will void your warranty and may present a fire hazard.

The warranty will be voided by, and the warrantor disclaims any responsibility for the following actions:

- Installation of any damaged fireplace or vent system component.
- Modification of the fireplace or vent system.
- Installation other than as instructed by Empire Comfort Systems, Inc.
- Improper positioning of the logs, glass door, optional accessories or decorative rock.
- Installation and/or use of any component part not manufactured or approved by manufacturer.

Glass Specifications

Optional glass door kits manufactured with tempered glass may be installed in hazardous locations such as bathtub enclosures as defined by the Consumer Product Safety Commission (CPSC). The tempered glass has been tested and certified to the requirements of **ANSI Z97.1** and **CPSC 16 CFR 1202** (Safety Glazing Certification Council **SGCC# 1595** and **1597**. Architectural Testing, Inc. Reports **02-31919.01** and **02-31917.01**).

This statement is in compliance with **CPSC 16 CFR Section 1201.5** "Certification and labeling requirements" which refers to **15 U.S. Code (USC) 2063** stating "...Such certificate shall accompany the product or shall otherwise be furnished to any distributor or retailer to whom the product is delivered."

SPECIFICATIONS

	BVD34FP	BVD36FP	BVP42FP
Input Btu/hr Maximum	21,000	25,000	30,000
KWH (Maximum)	6.2	7.3	8.8
B-Vent Size	4" Diameter	6" Diameter	6" Diameter
NAT. (Standard)			
Orifice	#44 (.086) P-252	#42 (.0935) P-286	#37 (.104) P-213
Air Shutter Opening	1/8" (3.2mm)	1/8"(3.2mm)	1/8" (3.2mm)
*LP (Conversion Kit Required)			
Orifice	1.35mm P-289	1.45 mm P-208	1.65mm P-250
Air Shutter Opening	5/16" (7.9mm)	5/16" (7.9mm)	Full Open
Height without standoff	32 3/4"(832mm)	34 3/4"(883mm)	34 3/4"(883mm)
Width	37" (940mm)	39" (990mm)	43" (1,092mm)
Depth	14 7/8" (378mm)	18 3/8" (467mm)	18 3/8" (467mm)
Gas Inlet Shutoff Valve (Pipe)	1/2 NPT	1/2 NPT	1/2NPT

NOTE: Air shutter settings are factory minimum settings. Some venting configurations may require minor air shutter adjustments for optimum performance.

***NOTE:** LP Conversion kits are included on the 120v. direct ignition model fireplaces. For millivolt models, use kit #19160 for BVD34FP Series, kit #19161 for BVD36FP Series, and kit #19162 for BVP42FP Series.

Remote Control Options & Accessories	Description
FRBC	MILLIVOLT BATTERY REMOTE ON/OFF
FREC	DIRECT IGNITION/MILLIVOLT 120V ON/OFF REMOTE
FWS-1	DIRECT IGNITION/MILLIVOLT WALL SWITCH

FIREPLACE DIMENSIONS

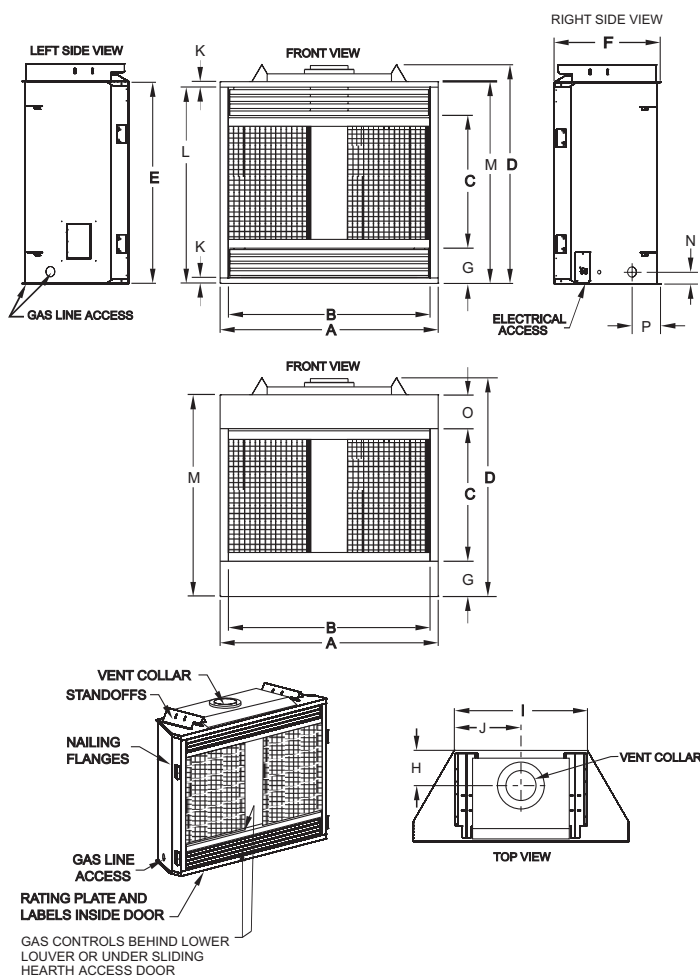

Figure 1

Dim	BVD34	BVD36	BVP42
A	37" 940mm	39" 990mm	43" 1092mm
B	34" 864 mm	36" 914mm	40" 1,016mm
C	22 7/8" 581mm	24 7/8" 632mm	24 7/8" 632mm
D	35 5/8" 905 mm	37 5/8" 956 mm	37 5/8" 956 mm
E	32 3/4" 832mm	34 3/4" 883 mm	34 3/4" 883 mm
F	14 7/8" 378mm	18 3/8" 467mm	18 3/8" 467mm
G	6 3/8" 162mm	6 3/8" 162mm	6 3/8" 162mm
H	5 7/8" 149mm	8 3/8" 213mm	6 3/8" 162mm
I	24 1/2" 622mm	22 1/2" 572mm	26 1/2" 673mm
J	12 1/4" 311mm	11 1/4" 286mm	13 1/4" 337mm
K	1 1/4" 32mm	1 1/4" 32mm	1 1/4" 32mm
L	31 3/4" 807mm	33 3/4" 857mm	33 3/4" 857mm
M	32 11/16" 830mm	34 11/16" 881mm	34 11/16" 881mm
N	2 1/16" 53mm	2 1/16" 53mm	2 1/16" 53mm
O	5 5/8" 143mm	5 5/8" 143mm	5 5/8" 143mm
P	4 7/8" 124mm	4 7/8" 124mm	4 7/8" 124mm

CLEARANCES

Clearance to Combustibles	
Back	0" (0 mm)
Side	0" (0 mm)
Floor	0" (0 mm)
Top Stand-off	0" (0 mm)
Top Framing Edge	1" (25mm)

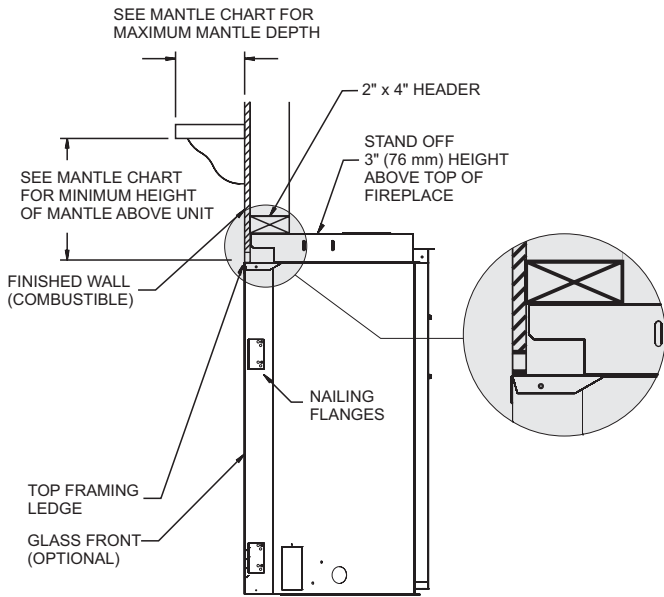

Figure 2

Combustible Material

No greeting cards, stockings or ornamentation of any type should be placed on or attached to the fireplace. The flow of heat can ignite combustibles.

Mantel Chart (Figure 3)

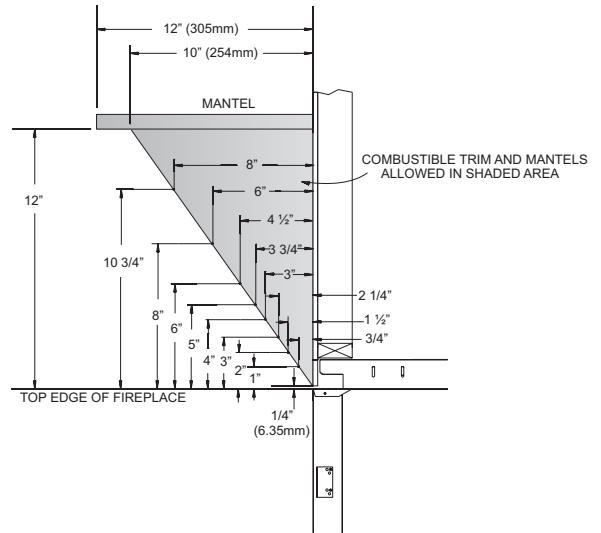

Figure 3

Clearances (Figure 4)

Clearance from top front edge of fireplace to ceiling is 36"
Clearance from side of fireplace to adjacent sidewall is 6".

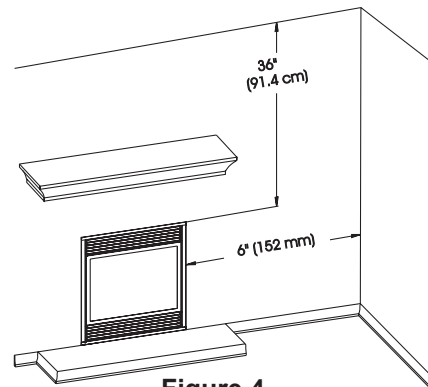

Figure 4

LOCATING FIREPLACE

Note: When you install your Fireplace on wall corner positions, a minimum of 6 inches clearance must be maintained from the perpendicular side wall and the screened opening of the appliance.

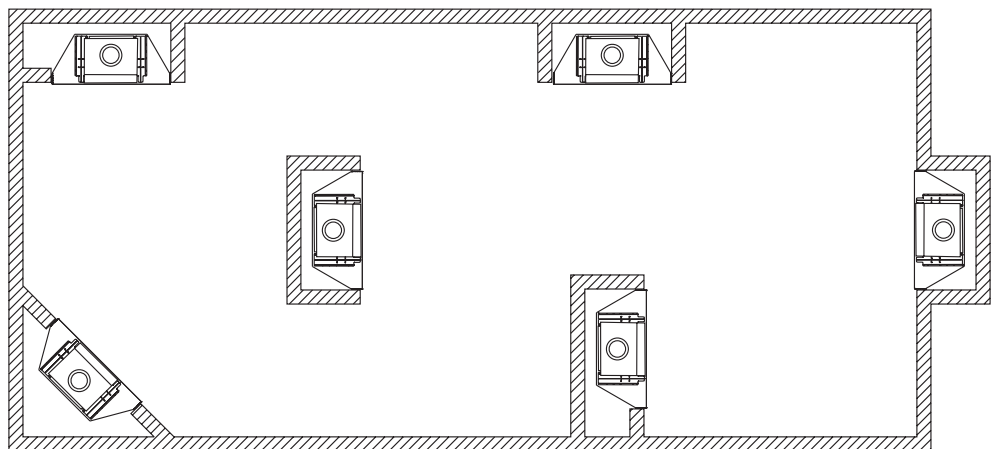

Figure 5

GAS SUPPLY

The gas pipeline can be brought in through the right or left side of the appliance. Consult the current National Fuel Gas Code, ANSI Z223.1 CAN/CGA-B149 (.1 or .2) installation code.

Recommended Gas Pipe Diameter				
Pipe Length (Feet)	Schedule 40 Pipe Inside Diameter		Tubing, Type L Outside Diameter	
	Nat.	L.P.	Nat.	L.P.
0-10	1/2" 12.7mm	3/8" 9.5mm	1/2" 12.7mm	3/8" 9.5mm
11-40	1/2" 12.7mm	1/2" 12.7mm	5/8" 15.9mm	1/2" 12.7mm
41-100	1/2" 12.7mm	1/2" 12.7mm	3/4" 19mm	1/2" 12.7mm
101-150	3/4" 19mm	1/2" 12.7mm	7/8" 22.2mm	3/4" 1.9 mm

Note: Never use plastic pipe. Check to confirm whether your local codes allow copper tubing or galvanized.

Note: Since some municipalities have additional local codes, it is always best to consult your local authority and installation code.

The use of the following gas connectors is recommended:

- ANS Z21.24 Appliance Connectors of Corrugated Metal Tubing and Fittings.
- ANS Z21.45 Assembled Flexible Appliance Connectors of Other Than All-Metal Construction

The above connectors may be used if acceptable by the authority having jurisdiction. The state of Massachusetts requires that a flexible appliance connector cannot exceed three feet in length.

FLEXIBLE GAS LINE CONNECTION

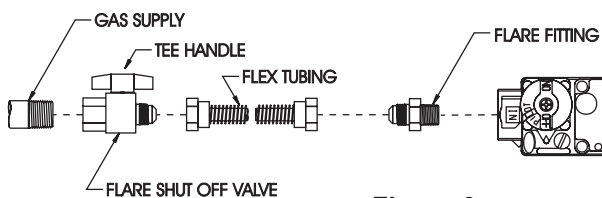

Figure 6

	Gas Supply Pressure (inches w.c.)		
	Minimum	Normal	Maximum
Natural Gas	4.5"	7.0"	14.0"
LP (Propane)	10.8"	11.0"	14.0"
	Manifold Pressure (inches w.c.)		
	Normal (HI)		
Natural Gas	3.5"		
LP (Propane)	10.0"		

Installing a New Main Gas Cock

Each appliance should have its own manual gas cock.

A manual main gas cock should be located in the vicinity of the unit. Where none exists, or where its size or location is not adequate, contact your local authorized installer for installation or relocation.

Compounds used on threaded joints of gas piping shall be resistant to the action of liquefied petroleum gases. The gas lines must be checked for leaks by the installer. This should be done with a soap solution watching for bubbles on all exposed connections, and if unexposed, a pressure test should be made.

Never use an exposed flame to check for leaks. Appliance must be disconnected from piping at inlet of control valve and pipe capped or plugged for pressure test. Never pressure test with appliance connected; control valve will sustain damage!

NOTE: The millivolt gas controls are equipped with a captured screw type pressure test point, therefore it is not necessary to provide a 1/8" test point up stream of the control.

On direct ignition valves, hex plugs may be replaced with hose fittings for pressure checks, then reinstalled before operating fireplace.

When using copper or flex connector use only approved fittings.

The appliance and it's individual shut off valve must be disconnected from supply piping system during any pressure testing of that system at test pressures in excess of 1/2 psig (3.5kPa).

The appliance must be isolated from the gas supply piping system by closing its individual manual shut off valve during any pressure testing of the gas supply piping system at test pressures equal to or less than 1/2 psig (3.5kPa).

Attention! If one of the procedures results in pressures in excess of 1/2 psig (14" w.c.) (3.5 kPa) on the fireplace gas valve, it will result in a hazardous condition.

GAS SUPPLY (CONT)

Checking Manifold Pressures

Both Propane and Natural gas valves have a built-in pressure regulator in the gas valve. Natural gas models will have a manifold pressure of approximately 3.5" w.c. (.871kPa) at the valve outlet with the inlet pressure to the valve from a minimum of 4.5" w.c. (1.120kPa) for the purpose of input adjustment to a maximum of 14.0" w.c. (3.484kPa). Propane gas models will have a manifold pressure approximately 10.0" w.c. (2.49kPa) at the valve outlet with the inlet pressure to the valve from a minimum of 10.8" w.c. (2.68kPa) for the purpose of input adjustment to a maximum of 14.0" w.c. (3.484kPa).

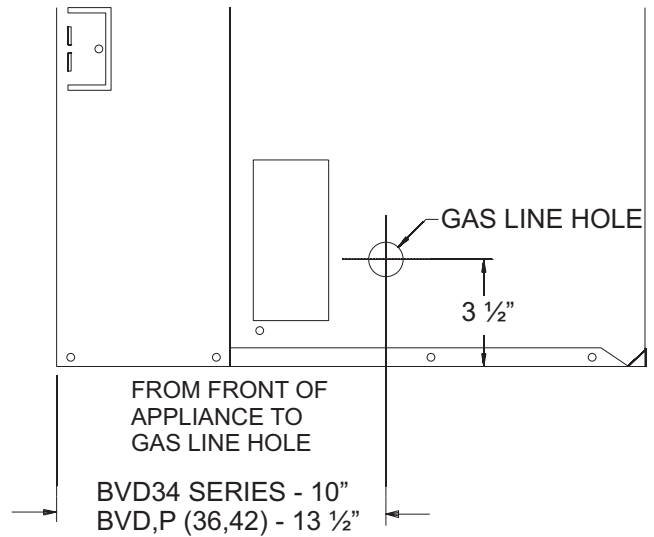

Figure 7

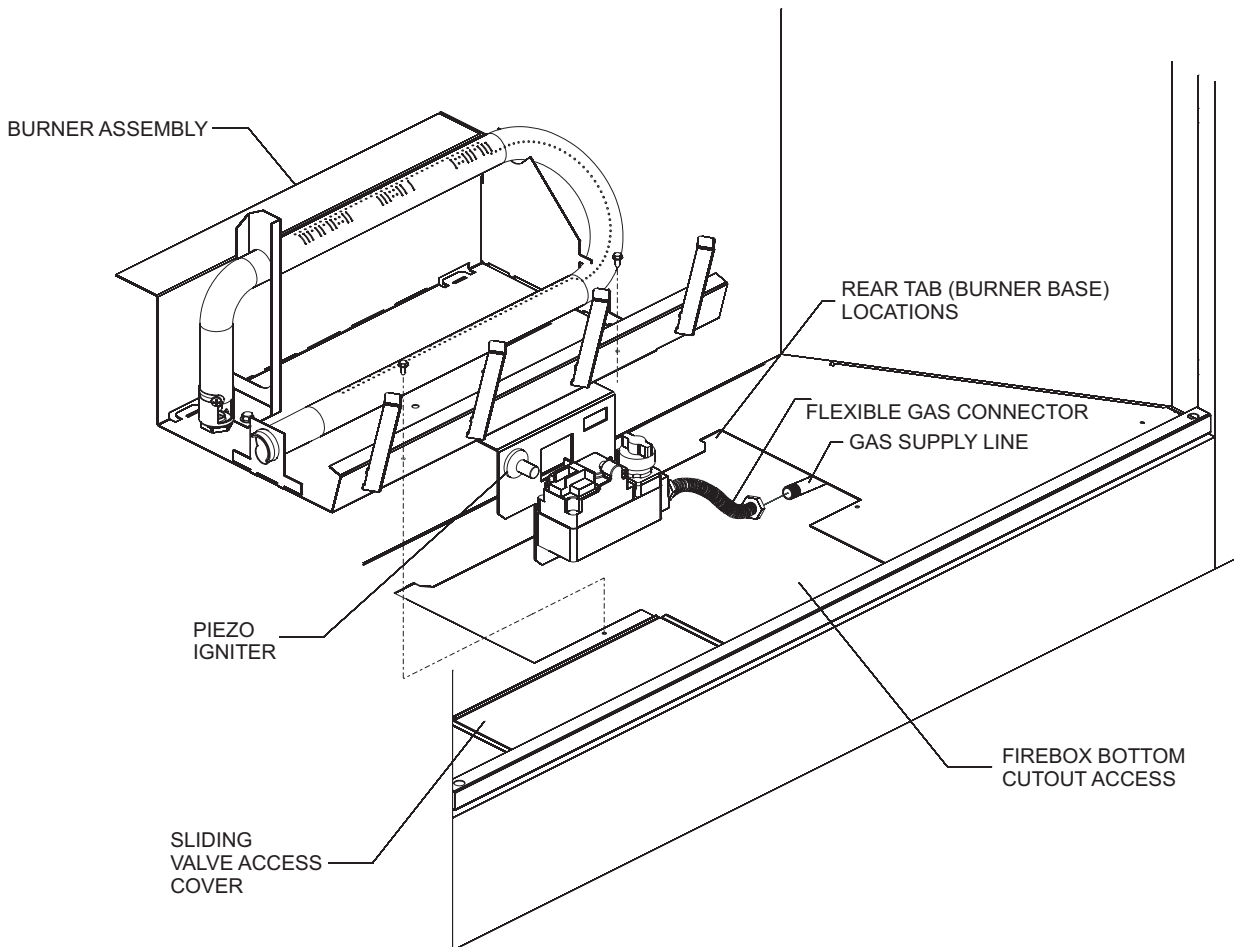

Figure 8

INSTALLATION

Framing and Finishing

1. Choose unit location.
2. Frame in fireplace with a header across the top. It is important to allow for the finished face thickness when setting the depth of the frame. **See Figures 9 & 11.**
3. Attach fireplace to framing using (4) adjustable nailing flanges. Preset depth to suit facing material (adjustable to 1/2", 5/8" or 3/4" depths).
4. Use (8) 1/2" hex-head screws supplied in hardware package to screw through slotted holes in nailing flanges, then screw into pre-drilled holes on fireplace side. Measure from face of fireplace to face of the nailing flanges to determine final depth.

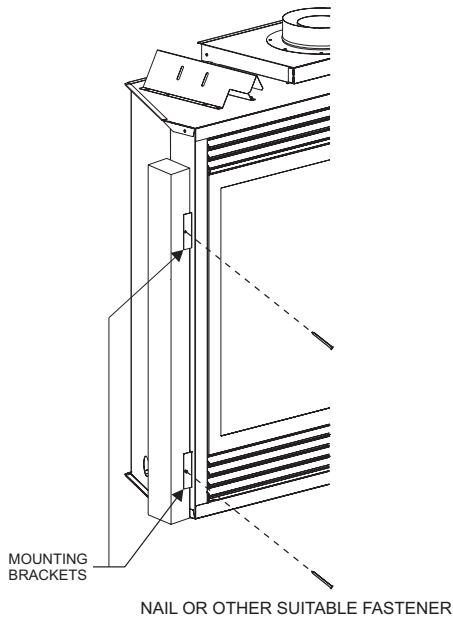

Figure 9

Vent Pipe Clearance

Note: Maintain one inch (1") of clearance around vertical vent pipe. Follow the B-Vent system instructions for installation requirements and clearances. Failure to follow the B-Vent manufacturer's instructions may cause improper draft and possible fire hazard.

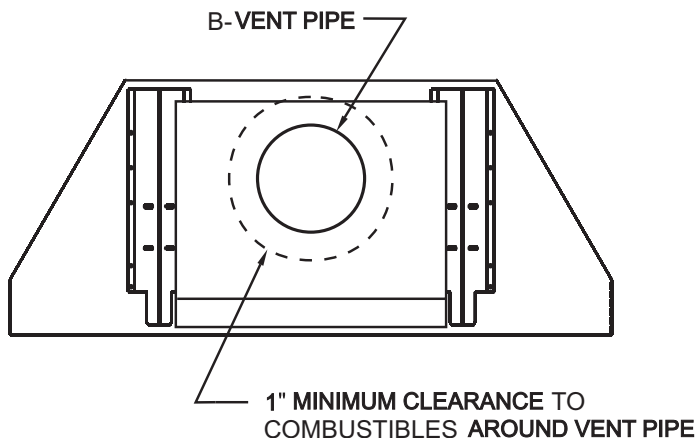

Figure 10

Install the Fresh Air Kit - BVA1

A fresh air kit is available as an optional feature with this appliance. The fresh air kit helps to decrease the amount of room air taken by utilizing outside air for combustion. It is strongly recommended that it be installed. Installation of the fresh air kit should be performed at the framing stage of the fireplace installation.

The fresh air kit installs on the left side of the fireplace. To install the BVA1 fresh air kit, refer to the installation instructions provided with the kit.

Note: The outside air kit can terminate at any level with the exception that it must terminate at least 1 ft below the vent termination cap. The fresh air kit inlet hood should be positioned at least 2 ft above the ground level, in a manner that will not allow snow, leaves, etc. to block the inlet.

WARNING: Exhaust products of gasoline engines are hazardous. The outside air must not be taken from a garage space, attic spaces, basements, or above the roofing where other heating appliance, fans, or chimneys exhaust or utilize the air.

Framing (Figure 11)

Fireplace framing can be built before or after the fireplace is set in place. Framing should be positioned to accommodate wall covering and fireplace facing material. The fireplace framing should be constructed of 2 x 4 lumber or heavier. The framing headers may rest on the fireplace standoffs. Refer to Figure 11 for minimum framing dimensions.

CAUTION: MEASURE FIREPLACE DIMENSIONS AND VERIFY FRAMING METHODS, AND WALL COVERING DETAILS BEFORE FRAMING CONSTRUCTION BEGINS.

Framing dimension "A" includes a three inch clearance for standoffs on firebox.

INSTALLATION (CONT)

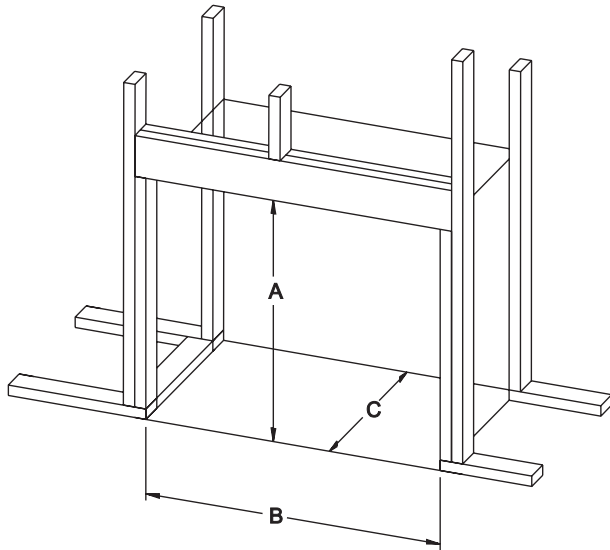

Minimum Framing Dimensions

	BVD34	BVD36	BVP42
"A"	35 3/4" (908mm)	37 3/4" (959mm)	37 3/4" (959mm)
"B"	37 3/8" (949mm)	39 3/8" (1,000mm)	43 3/8" (1,102mm)
"C"	14 3/8" (378mm)	17 7/8" (454mm)	17 7/8" (454mm)

Note: Dimension "C" is the minimum with the fireplace face extending 1/2" in front of the framing to allow for finishing materials.

Figure 11

Attention: Add 3-3/4" to "A" dimensions when using a flush mantel base.

Attention: If a base or mantel is not used and the appliance is installed directly on carpeting, tile or other combustible material other than wood flooring, it shall be installed on a metal or wood panel extending the full width and depth of the appliance. The vertical dimension in Figure 11 must be adjusted when a metal or wood panel is placed beneath the appliance.

Finishing (Figure 12)

Finish the walls with the material of your choice. Only non-combustible materials may be used to cover the black fireplace front.

Warning: When finishing the fireplace never obstruct or modify the air inlet/outlet louvers in any manner. Provide adequate clearances around air openings into the combustion chamber.

Caution: If the joints between the finished wall and the fireplace surround (top and sides) are sealed, a 300°F minimum sealant material must be used. These joints are not required to be sealed. Only non-combustible material (using 300°F minimum adhesive if needed), can be applied as facing to the fireplace surround.

Combustible Surround Installation

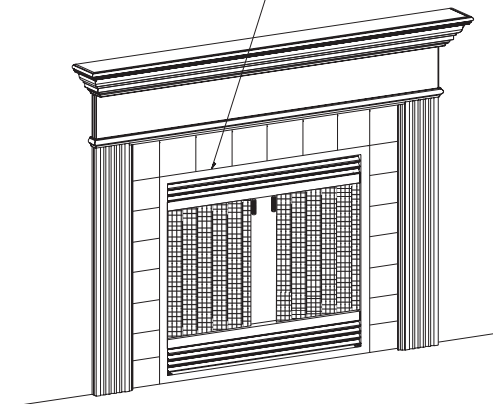
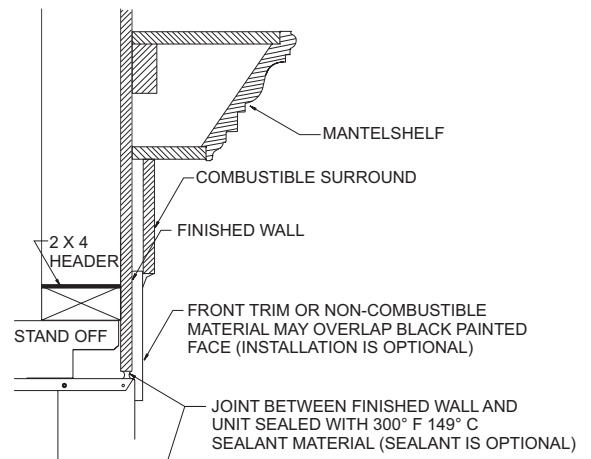

**Louvered Models
Figure 12a**

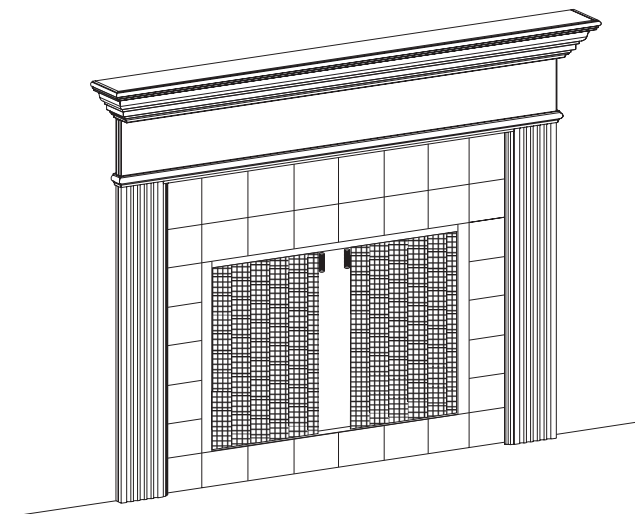

**Flush Face Models
Figure 12b**

Attention: Cold climate installation recommendation: When installing this unit against a non-insulated exterior wall, it is recommended that the outer walls be insulated to conform to applicable insulation codes.

VENTING

Vent Runs

In planning the installation for the fireplace, it is necessary to install certain components before the appliance is completely positioned and installed. These include the vent system, gas piping for the appliance, Fresh Air Kit, and the electrical wiring. (The fan option is available for louvered models only. Electric ignition models will require electrical service to junction box).

The appliance can be mounted on any of the following surfaces:

1. A flat, hard combustible (burnable) surface.
2. A raised wooden platform.
3. Four (4) corner supports. (Example: Four (4) concrete masonry blocks.) These supports must be positioned so they contact all four (4) perimeter edges on the bottom of the unit.

Locate and mark the center point of the vent pipe using a nail on the underside of the roof. Drive the nail through the center point. Mark the outline of the roof hole around this center point.

NOTE: Size of the roof hole dimensions depend on the pitch of the roof. There must be a 1 inch clearance (25mm) to the vertical pipe sections. This clearance is to all combustible material.

Cover the opening of the vent pipe and cut and frame the roof hole. Use framing lumber the same size as the roof rafters and install the frame securely. Flashing anchored to frame must withstand high winds. The storm collar is placed over this joint to make a water-tight seal. Non-hardening sealant should be used to completely seal this flashing installation.

Determining Minimum Vent Height Above the Roof.

WARNING: Major U.S. building codes specify minimum chimney and/or vent height above the roof top. These minimum heights are necessary in the interest of safety. These specifications are summarized in Figures 14 and 15.

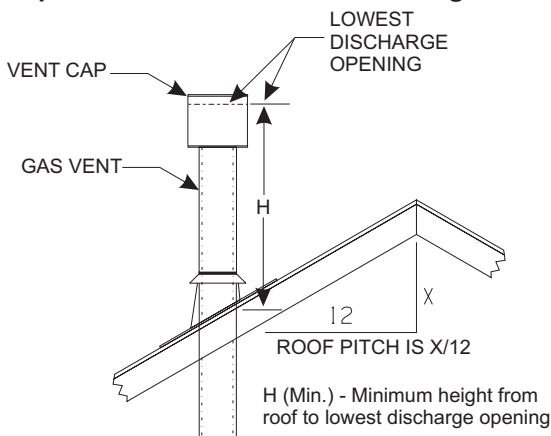

ROOF PITCH	H (Min.)
Flat to 6/12	12" (305 mm)
6/12 to 7/12	15" (381 mm)
Over 7/12 to 8/12	18" (457 mm)
Over 8/12 to 16/12	24" (610 mm)
Over 16/12 to 21/12	36" (914 mm)

Figure 13

Note that for steep roof pitches, the vent height must be increased. In high wind conditions, nearby trees, adjoining roof lines, steep pitched roofs, and other similar factors can result in poor draft, or down-drafting. In these cases, increasing the vent height may solve this problem.

General Maintenance

Conduct an inspection of the venting system semi-annually. Recommended areas to inspect are as follows:

1. Check areas of the venting system which are exposed to the elements for corrosion. These will appear as rust spots or streaks and, in extreme cases, holes. These components should immediately be replaced.
2. Remove the cap and shine a flashlight down the vent. Remove any bird nests or other foreign material.
3. Check for evidence of excessive condensate, such as water droplets forming in the inner liner and subsequently dripping out at joints. Condensate can cause corrosion of caps, pipe and fittings. It may be caused by having excessive lateral runs, too many elbows and exterior portions of the system being exposed to cold weather.
4. Inspect joints to verify that no pipe sections or fittings have been disturbed and, consequently, loosened. Also, check mechanical supports, such as wall straps or plumbers' tape for rigidity.

A removable panel or other means must be provided in the enclosure for visual inspection of the flue connection.

NOTE: This also pertains to vertical vent systems installed on the outside of the building.

Installing the Vent System in a Chase

A chase is a vertical box-like structure built to enclose the gas appliance and/or its vent system. Vertical vent runs on the outside of a building may be, but are not required to be installed inside a chase.

CAUTION: Treatment of firestop spacers and construction of the chase may vary with the type of building. These instructions are not substitutes for the requirements of local building codes. Therefore, your local building codes must be checked to determine the requirements for these steps.

NOTE: When installing this vent system in a chase, it is always good building practice to insulate the chase as you would the outside walls of your home. This is especially important for cold climate installations. Upon completion of building your chase framing, install the vent system by following the instructions in this manual. Remember to build the chase large enough so that minimum clearance of combustible materials (including insulation) to the vent system are maintained.

WARNING! This appliance must not be connected to a chimney flue servicing a separate solid fuel or gas fuel burning appliance.

VENTING (CONT)

Vent Size

Model BVD34FP series uses a 4" B-Vent for operation.
Models BVD36FP and BVP42FP series use a 6" B-Vent for operation.

Never downsize venting diameters.

Clearances

Vent clearances are per vent manufacturer's specifications

Vent Configuration

Various venting configurations are shown in Figures 14 and 15 from which maximum vent runs can be determined.

WARNING - RISK OF FIRE!

Always maintain minimum clearances or greater around the vent system. Do not pack air spaces with insulation or other material.

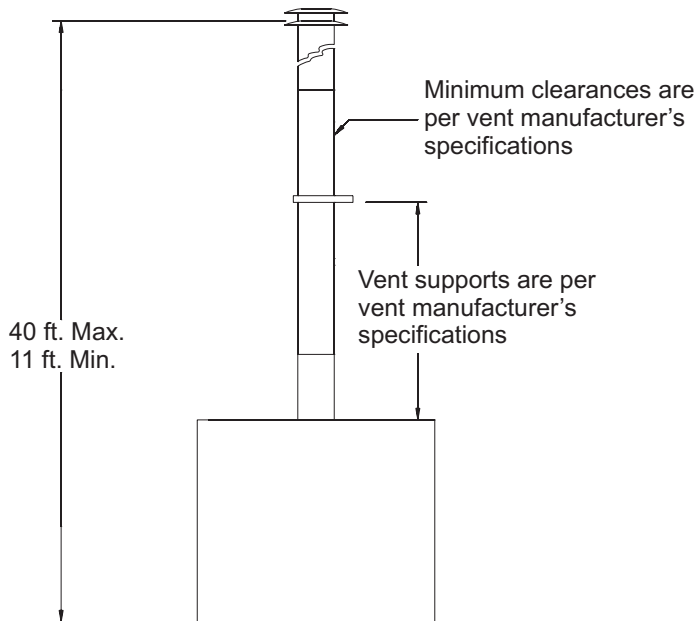

Vertical Venting - No Elbows
Figure 14

Offset Venting - With Elbows

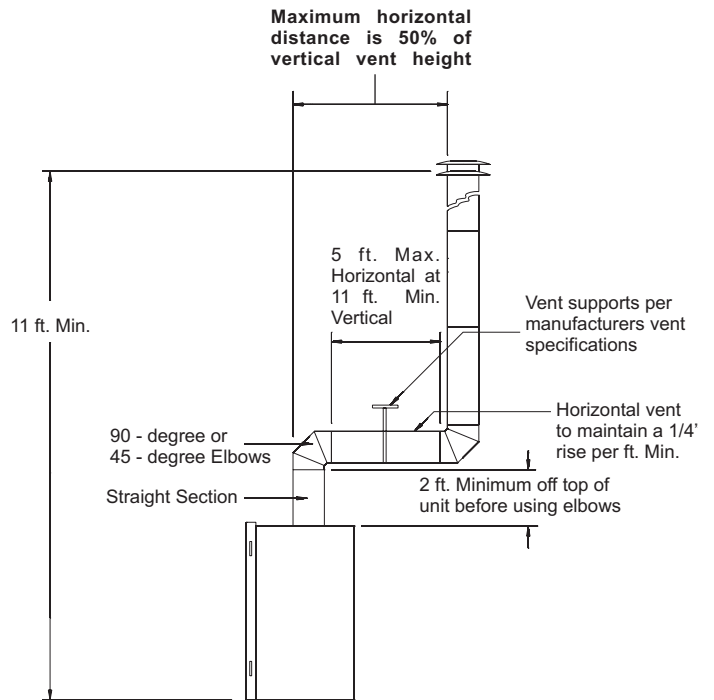

Figure 15

LOG PLACEMENT (5 LOG SET)

Before you begin: if you are installing logs into the BVD34 or BVD36 model, then this fireplace is supplied with a set of five ceramic fiber logs. Do not handle these logs with your bare hands! Always wear gloves to prevent skin irritation from ceramic fibers. After handling logs, wash your hands gently with soap and water to remove any traces of fibers.

The positioning of the logs is critical to the safe and clean operation of this fireplace. Sooting and other problems may result if the logs are not properly and firmly positioned in the fireplace. Please refer to **Figure 16** and **Figure 17** and corresponding WARNING when completing following log placement instructions.

1. Place front logs (#1 and #2) between front grate flange and main burner. Align notches on front logs with locator tabs in base.
2. Place middle log (#3) between front and rear loop of burner.
- Note: Do not place log on top of pilot assembly.
3. Place rear log (#4) on rear log shelf. Bottom flange of log must be placed between the log shelf and burner tube.
4. Place branch (#5) onto (#1) log and flat area on (#3) log. The bottom of the branch is to be placed behind the grate tang that is second from the left.
5. Place decorative rock in front of grates and sides of main burner pan.

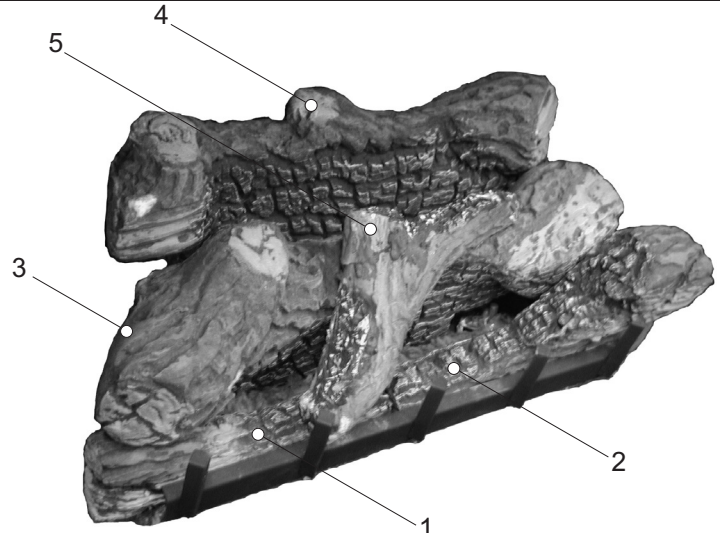

Figure 16

WARNING: Failure to position the parts in accordance with this diagram or failure to use only parts specifically approved with this appliance may result in property damage or personal injury.

Attention: Do not use Figure 16 or Figure 17 to order logs. Refer to parts list on page 28 and parts view on page 29 to order logs and/or ember material for your appropriate fireplace model.

ATTENTION: Do not place decorative rock on logs or burner. The decorative rock should only be placed on the fireplace floor.

EMBER MATERIAL PLACEMENT ON BURNER

6. After all logs are positioned properly, apply Rockwool ember material to the front burner port area. To apply, carefully separate the ember material into small amounts no larger than "dime size" pieces. Fluffed up pieces one layer thick on top of the burner generally works best, and will provide the best ember glow. Do not place ember material more than one layer thick. No more than (1) small packet of ember material (part no. 15999) evenly placed on the burner, is recommended on BVD34 and BVD36 models. Using additional ember material will decrease the amount of ember glow effect. Extra ember material should be saved for future ember applications as necessary. See Figure 17.

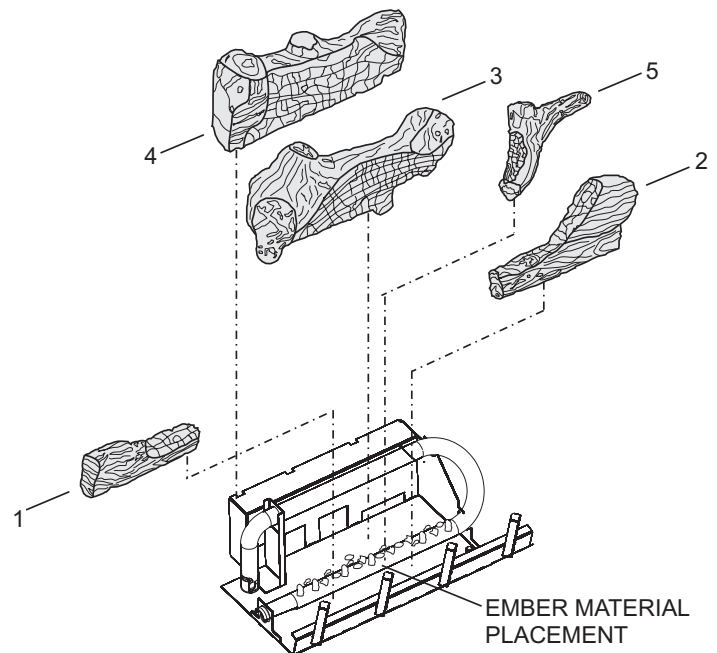

Figure 17

Optional Platinum Bright Ember Kits are available from your Fireplace Dealer. These embers may be used with all BVD/BVP Series fireplaces. Order and use as indicated as below.

Platinum Bright Embers	PE-20-1
------------------------	---------

Note: A single layer of embers is to be used when applying Platinum Bright Embers (alone or in combination with production embers) to the burner.

LOG PLACEMENT (4 LOG SET)

Before you begin: This fireplace is supplied with a set of four ceramic fiber logs. Do not handle these logs with your bare hands. Always wear gloves to prevent skin irritation from ceramic fibers. After handling logs, wash your hands gently with soap and water to remove any traces of fiber.

The positioning of logs is critical to safe and clean operation of this fireplace. Sooting and other problems may result if the logs are not properly and firmly positioned in the firebox. Please refer to **Figure 18**, **Figure 19**, and **Figure 20** and corresponding WARNING, when completing the following log placement steps.

1. Remove top louver, grasp louver, lift and pull forward.
2. Lower bottom louver, lift and hinge forward.
3. Release two glass frame spring clamps at bottom of firebox
4. Place rear (#1) log onto two (2) pins on rear log support.
5. Place left, front (#2) log onto two (2) left, front pins on burner pan.
6. Place right, front (#3) log onto two (2) right, front pins on burner pan.
7. Place Branch (#4) onto one (1) pin on rear log
8. Place decorative rock in front of grates and sides of main burner.

ATTENTION: Do not place decorative rock on logs or on burner. The decorative rock should only be placed on the fireplace floor.

9. After all logs are properly positioned, place small "dime" size pieces of Rockwool lightly across the front round "blueflame" ports. Place the ember material (Rockwool pieces) side by side. Do not stack more than one layer of embers across the burner ports. **See Figure 18.**
10. Replace glass door onto firebox.
11. Secure the two glass frame spring clamps at bottom of firebox.
12. Align the tabs on top louver brackets with slots in front posts to secure top louver.
13. Close bottom louver. Lift slightly to engage the end tabs into the slots in fireplace sides to close louver panel.



Figure 19

WARNING: Failure to position the parts in accordance with this diagram or failure to use only parts specifically approved with this appliance may result in property damage or personal injury.

Attention: Do not use Figure 61 or Figure 62 to order logs. Refer to parts view on page 57 and parts list on pages 58 and 59 to order logs and/or ember material for your appropriate fireplace model.

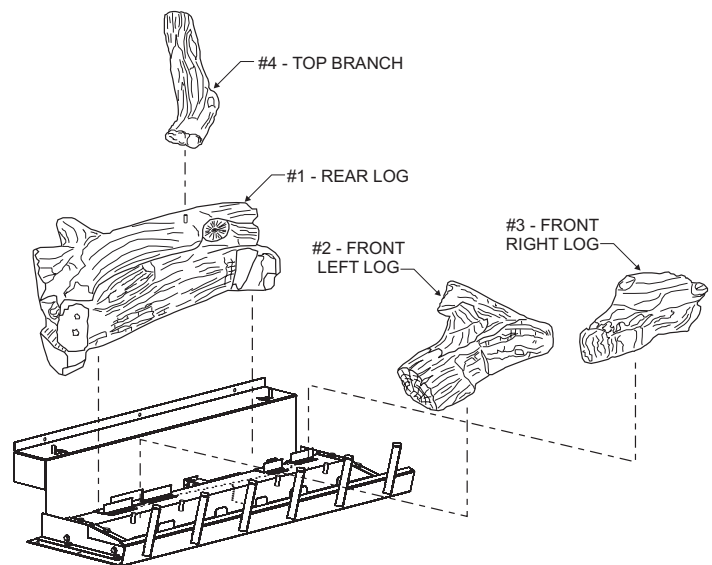

Figure 20

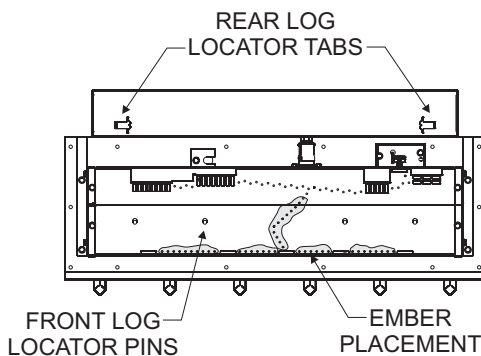

Figure 18

OPERATING INSTRUCTIONS

750 Millivolt System

The standing pilot (750 millivolt system) is a continuous burning pilot. The pilot remains ON even when the main burner is OFF.

When you ignite the pilot, the thermopile produces millivolts (electrical current) which energizes the magnet in the gas valve. After 30 seconds to 1 minute time period you can release the gas control knob and the pilot will stay ON. Allow your pilot flame to operate an additional one (1) to two (2) minutes before you turn the gas control knob from the PILOT position to the ON position. This time period allows the millivolts (electrical current) to build-up to a sufficient level allowing the gas control to operate properly.

1. Follow the SAFETY and LIGHTING INSTRUCTIONS for standing pilot controls found in this manual and on labels found in control compartment behind the door assembly.

CAUTION: During the initial purging and subsequent lightings, never allow the gas valve control knob to remain depressed in the "pilot" position without pushing the piezo ignitor button at least once every second.

2. During the operating season, leave the control valve knob in the "ON" position. This will allow the pilot flame to remain lit. Turn the burner flame on or off with the fireplace wall switch or remote controls.
3. When the operating season is over, turn the wall switch

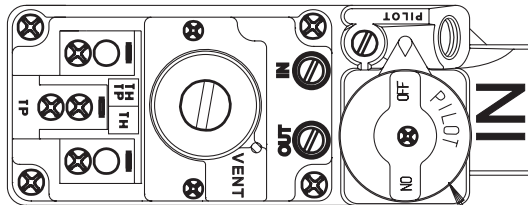

**GAS CONTROL KNOB
SHOWN IN "OFF" POSITION.**

or remote to "OFF" and the control valve to "OFF". The system, including the pilot light, will be shut down.

Figure 21

The OWNER should carefully read and follow these operating instructions at all times. Lower the door assembly to view the gas controls for the fireplace.

Initial Lighting

Upon completing the gas line or turning the gas valve on after it has been in the "OFF" position, a small amount of air will be in the lines. When first lighting the fireplace, it will take a few minutes for the lines to purge themselves of this air. Once the purging is complete, the fireplace will light and operate satisfactorily.

Subsequent lightings of the appliance will not require such purging if the gas valve is not turned to "OFF."

Pilot Flame (Figure 22)

The thermopile (standing pilot) tips should be covered with

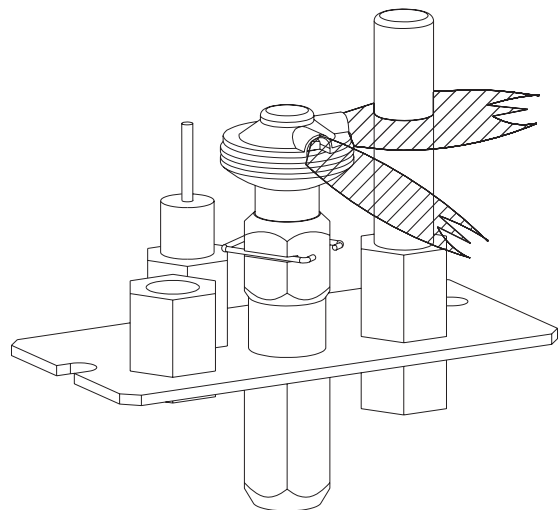

flame.

Figure 22

OPERATING INSTRUCTIONS (CONT)

STANDING PILOT OPERATING INSTRUCTIONS

The fireplace is equipped with a 15 foot length of wire that can be used to connect the valve to a wall switch (installer provided) or remote control receiver.

See instructions packed with each of the following optional switches or controls for proper installation, operation, and maintenance.

Wall Switch, FWS-1 (optional)

On millivolt valve models, a 15' wall switch wire is included. Connect the two leads to a wall switch (installer supplied). See Figure 23.

FRBC Battery Operated Remote Control

To connect the FRBC remote to the millivolt gas valve on your "B-Vent" Fireplace, disconnect one wire terminal lead (wall switch wire) from gas valve, separate/split wall switch wire lead approximately 18 inches. Cut the removed lead 12 inches long and strip both cut ends. After stripping and baring the wire ends, connect the two stripped ends to the remote receiver. Reconnect the 1/4" insulated wire terminal (short 18" wire) to the gas valve wire terminal. See Figure 23.

Millivolt Control

The valve regulator controls the burner pressure which should be checked at the pressure test point. Turn captured screw counter clockwise 2 or 3 turns and then place tubing to pressure gauge over test point (Use test point "A" closest to control knob). After taking pressure reading, be sure and turn captured screw clockwise firmly to re-seal. Do not over torque. Check for gas leaks.

Millivolt thermopile is self generating. Gas valve does not require 24 volts or 110 volts.

Check System Operation

Millivolt system and all individual components may be checked with a millivolt meter 0-1000 MV range.

It is important to use wire of a gauge proper for the length of the wire:

Recommended Wire Gauges	
Maximum Length	Wire Gauge
1' to 10'	18
10' to 25'	16
25' to 35'	14

Electric (120 volt) Operated Remote Control, FREC

CAUTION: Disconnect all electrical supply to the fireplace prior to installing the remote control optional equipment.

Installation of the 120 Volt Receiver

Note: If you have a louvered model fireplace and will be installing the blower option, the fireplace junction box receptacle should be wired in accordance with Figure 28 for proper independent operation of the FREC remote and the optional FBB4 Blower kit.

To connect the FREC Remote to the millivolt gas valve on your "B"-Vent fireplace, disconnect both of the insulated wall switch wire terminal leads from the gas valve and discard the wall switch wire. Connect the two wire leads from the FREC receiver to the TH and TH/TP terminals on the gas valve.

Next, attach the short power cord to the remote receiver, then plug the power cord into the junction box receptacle located at the bottom right side of the fireplace.

The remote receiver should be located on the floor of the fireplace to the right of the gas valve.

Attention: The Velcro loop and hook are not necessary in this installation but can be used to secure remote receiver.

Refer to remote control installation and operating instructions for more details on remote control.

STANDING PILOT WIRING DIAGRAM

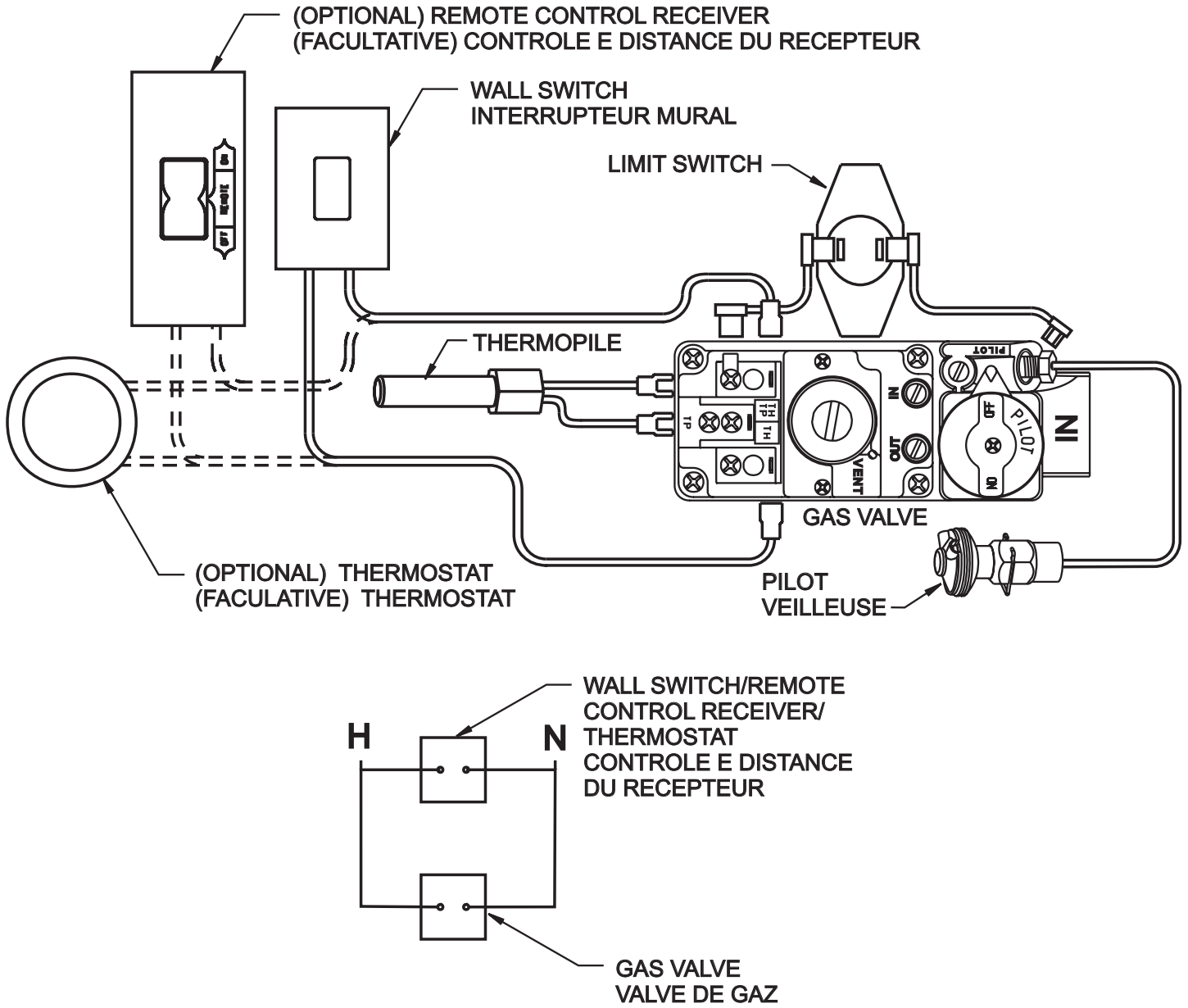

Figure 23

STANDING PILOT LIGHTING INSTRUCTIONS

FOR YOUR SAFETY, READ BEFORE LIGHTING

WARNING: IF YOU DO NOT FOLLOW THESE INSTRUCTIONS EXACTLY, A FIRE OR EXPLOSION MAY RESULT CAUSING PROPERTY DAMAGE, PERSONAL INJURY, OR LOSS OF LIFE

- A.** This appliance has a pilot which must be lighted by hand. When lighting the pilot, follow these instructions exactly.
- B.** **BEFORE LIGHTING** smell all around the appliance area for gas. Be sure to smell next to the floor because some gas is heavier than air and will settle on the floor.
- WHAT TO DO IF YOU SMELL GAS**
- Do not try to light any appliance
 - Do not touch any electric switch.
 - Do not use any phone in your building.
 - Immediately call your gas supplier from a neighbor's phone.
- Follow the gas supplier's instructions.
 - If you can not reach your gas supplier, call the fire department.
- C.** Use only your hand to push in or turn the gas control knob. Never use tools. If the knob will not push in or turn by hand, don't try to repair it, call a qualified service technician. Force or attempted repair may result in a fire or explosion.
- D.** Do not use this appliance if any part has been under water. Immediately call a qualified service technician to inspect the appliance and to replace any part of the control system and any gas control which has been under water.

LIGHTING INSTRUCTIONS

1. STOP! Read the safety information above.
2. Set wall switch or remote to "OFF."
3. Turn off all electric power to the appliance (if applicable).
4. Open bottom louver assembly, or open valve access door.

5. Push in gas control knob slightly and turn clockwise to "OFF."

NOTE: Knob cannot be turned from "PILOT" to "OFF" unless knob is pushed in slightly. Do not force.

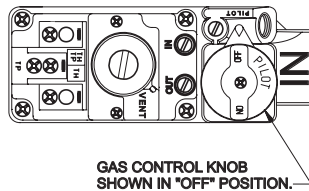

6. Wait ten (10) minutes to clear out any gas. Then smell for gas, including near the floor. If you smell gas, STOP! Follow "B" in the safety information on reverse. If you do not smell gas, go to the next step.
7. Find pilot - Follow metal tube from gas control. The pilot is behind the burner on the right side.

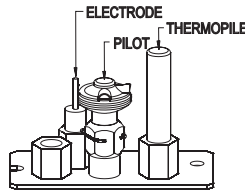

8. Turn gas control knob counterclockwise to "PILOT."
9. Push in control knob all the way and hold in. Repeatedly push the Piezo Ignitor Button until the pilot is lit. Continue to hold the control knob in for about one (1) minute after the pilot is lit. Release knob, and it will pop back up. Pilot should remain lit. If it goes out, repeat steps 5 through 9.
 - If knob does not pop up when released, STOP and IMMEDIATELY call a qualified service technician or gas supplier.
 - If the pilot will not stay lit after several tries, turn the gas control knob to "OFF" and call your service technician or gas supplier.
10. Turn gas control knob counterclockwise to "ON."
11. Close bottom louver assembly, or close valve access door.
12. Turn on all electric power to the appliance (if applicable).
13. Set wall switch or remote to "ON."

TO TURN OFF GAS TO FIREPLACE

1. Set wall switch or remote to "OFF."
2. Turn off all electric power to the appliance if service is to be performed (if applicable).
3. Open bottom louver assembly, or open valve access door.
4. Push in gas control knob slightly and turn clockwise to "OFF." Do not force.
5. Close bottom louver assembly, or close valve access door.

STANDING PILOT TROUBLESHOOTING

With proper installation and maintenance, your new Gas Fireplace will provide years of trouble-free service. If you do experience a problem, refer to the Trouble Shooting Guide below. This guide will assist a qualified service person in the diagnosis of problems and the corrective action to be taken.

1. Spark ignitor will not light pilot after repeated triggering of piezo ignitor button.

- a. Defective ignitor (no spark electrode)
 - Check for spark at electrode and pilot; if no spark and electrode wire is properly connected, replace ignitor.
- b. No gas or low gas pressure.
 - Check remote shut off valves from fireplace. Usually there is a valve near the main. There can be more than one (1) valve between the fireplace and main.
 - Low pressure can be caused by a variety of situations such as a bent line, too narrow diameter of pipe, or low line pressure. Consult with plumber or gas supplier.
- c. No LP in tank.
 - Check LP (propane) tank. Refill tank.

2. Pilot will not stay lit after carefully following lighting instructions.

- a. Defective thermopile.
 - Check that pilot flame impinges on thermopile. Clean and/or adjust pilot for maximum flame impingement.
 - Ensure the thermopile connections at the gas valve are fully tight.

3. Pilot burning, no gas to burner, valve knob “ON.”

- a. Wall switch, remote control or wires defective.
 - Check wires for proper connections. Place jumper wires across terminal at switch. If burner comes on, replace defective switch. If OK, place jumper wires across switch wires at gas valve-if burner comes on, wires are faulty or connections are bad.
- b. Thermopile may not be generating sufficient millivolts.
 - If the pilot flame is not close enough physically to the thermopile, adjust the pilot flame.
 - Be sure the wire connections from the thermopile at the gas valve terminals are tight and the thermopile is fully inserted into the pilot bracket.
 - Check the thermopile with a millivolt meter. Take the reading at TH-TP & TP terminals of the gas valve. The meter should read 350 millivolts minimum, while

holding the valve knob depressed in the PILOT position, with the pilot lit, and the switch in the OFF position. Replace the faulty thermopile if the reading is below the specified minimum.

—With the pilot in the ON position, disconnect the thermopile leads from the valve. Take a reading at the thermopile leads. The reading should be 350 millivolts minimum. Replace the thermopile if the reading is below the minimum.

- c. Defective valve.
 - Turn valve knob to ON. Place Remote/Off/On switch to ON. Check with millivolt meter at thermopile terminals. Millivolt meter should read greater than 200 millivolts. If the reading is okay and the main burner does not ignite, replace the gas valve.
- d. Plugged main burner orifice.
 - Check main burner orifice for blockage and remove.

4. Frequent pilot outage problem.

- a. Pilot flame may be too high or too low, or blowing (high), causing pilot safety to drop out.
 - Clean and adjust flame for maximum flame impingement on the thermocouple. Follow lighting instructions carefully.

5. The pilot and main burner extinguish while in operation.

- a. No LP (Propane) in tank.
 - Check LP (Propane) tank. Refill fuel tank.
- b. Bad thermopile or thermocouple.
 - Replace if necessary.
- c. Improper vent cap installation.
 - Check for proper installation and freedom from debris or blockage.

6. (Glass) Sooting

- a. Flame impingement on logs.
 - Check and adjust log position. Contact Empire Comfort Systems, Inc.
- b. Debris around throat of main burner.
 - Inspect the opening at the base of the main burner. It is imperative that NO material be placed in this opening.

STANDING PILOT PROPANE/LP GAS CONVERSION

"B-VENT" FIREPLACES	
Model	Conversion Kit Model (Part Number)
BVD34FP3 SERIES	BVCK34P (19160)
BVD36FP3 SERIES	BVCK36P (19161)
BVP42FP3 SERIES	BVCK42P (19162)

FOR CONVERSION TO LIQUEFIED PETROLEUM GAS

WARNING

This conversion kit is to be installed by an Empire Comfort Systems, Inc. dealer (or other qualified agency¹)* in accordance with the manufacturer's instructions and all codes and requirements of the authority having jurisdiction. Failure to follow instructions could result in serious injury or property damage. The qualified agency performing this work assumes responsibility for this conversion.

¹ National Fuel Gas Code Z223.1 (Latest Edition), Natural Gas and Propane Installation Code, CSA B149.1

*The term "qualified agency" means any individual, firm, corporation or company which either in person or through a representative is engaged in and is responsible for (a) the installation of gas piping or (b) the connection, installation repair, or servicing of equipment, who is experienced in such work, familiar with all precautions required, and has complied with all the requirements of the authority having jurisdiction.

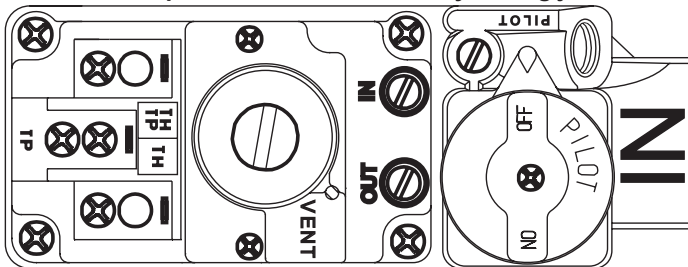

CHECK SAFETY SHUTDOWN PERFORMANCE

WARNING

Perform the safety shutdown test any time work is done on a gas system to avoid the possibility of fire or explosion with property damage, personal injury or loss of life.

SAFETY SHUTDOWN SYSTEM

Continuous Ignition Systems

- Place gas control knob in Pilot position. Main burner should go off and pilot should remain lit.
- Extinguish pilot flame. Pilot gas flow should stop within 3 minutes. Safety shutoff of pilot gas proves complete shutdown since safety shutoff valve blocks flow of gas to main burner and pilot.
- Wait 5 minutes, then relight pilot burner and operate system through one complete cycle to make sure all controls operate properly.

26534-5-0315

PARTS LIST

Conversion Kit Model	BVCK34P	BVCK36P	BVCK42P	
Part Description	Kit No. 19160	Kit No. 19161	Kit No. 19162	Quantity Supplied
Fireplace	BVD34FP3 SERIES	BVD36FP3 SERIES	BVP42FP3 SERIES	
Pilot Orifice	#35 (R-7658)	#35 (R-7658)	#35 (R-7658)	1
Main Burner Orifice	P-289 1.35mm	P-208 1.45mm	P-250 1.65mm	1
Dexen 10" w.c. Regulator	R-7548	R-7548	R-7548	1
Gas Conversion Label	2139	2139	2139	1

Gas input for "B-Vent" fireplace converted to Liquefied Petroleum Gas:

BVD34FP3 SERIES	21,000 BTU per hour
BVD36FP3 SERIES	25,000 BTU per hour
BVP42FP3 SERIES	30,000 BTU per hour

The "B-Vent" fireplace when converted to LP Gas will have manifold pressure of 10.0" w.c. at the valve outlet with the inlet pressure to the valve from a minimum of 10.8" w.c., for the purpose of input adjustment, to a maximum of 14.0" w.c.

INSTRUCTIONS FOR CONVERSION

- If the fireplace is installed, turn off gas and electric supply before making the gas conversion.
- Identify the fireplace model to be converted, and read all instruction steps prior to converting the gas valve.
- Remove all logs from the burner assembly.
- Open the sliding valve access door.
- Depress and turn the gas cock dial to the "OFF" position.

VALVE CONVERSION

- Remove two (2) screws, regulator, and gasket from gas valve control body.
- Install the new gasket, regulator, and gasket from gas valve control body.

BURNER ORIFICE CONVERSION - Tube style burners

- On models BVD(34,36)FP3 series fireplaces, you will have a U-shaped burner tube. To gain access to the main orifice, simply bend over the small retainer tab located at the front right end of the tube using pliers.
- Remove the 1/4" long screw from the air shutter at the left end of the tube.
- Pull up on the back of the burner and rotate forward to gain access to the main orifice. Remove the orifice and replace with the LP orifice designated in the orifice reference chart. Secure the new orifice.
- Pivot the burner tube back down in its original position mating with the air shutter, and reinstall the 1/4" long screw. Set the air shutter opening in accordance with the dimension shown in the reference chart for the appropriate model fireplace.

BURNER ORIFICE CONVERSION - Slope style burners

- 8b. On model BVP42FP3 series fireplaces, you will have a rectangular slope style burner. To gain access to the main orifice, disconnect the gas supply tubing at the air shutter.
- 9b. Remove the orifice holder from the air shutter, then remove the NG orifice.
- 10b. Replace the removed NG orifice with the new LP orifice designated in the orifice reference chart for your fireplace model. Secure the new orifice and replace the orifice/orifice holder back into the air shutter and secure.
- 11b. Loosen the air shutter screw and reset the air shutter opening in accordance with the dimension shown in the reference chart for the appropriate model fireplace.

PILOT ORIFICE CONVERSION

12. Locate the pilot assembly.
13. Pull upward on the round pilot flame hood to remove.
14. Using a 5/32" Hex Allen wrench, remove the pilot orifice, then replace with the new pilot orifice marked #35.

IMPORTANT: Failure to install the correct orifice will result in unit over-firing that could overheat the appliance and result in a fire.

15. Refer to log placement found in your fireplace installation manual to place logs onto the burner assembly.
16. Loosen screw and attach a manometer or pressure gauge to the outlet pressure tap of the control valve.
17. Turn on the gas supply. Turn on the electrical supply to the appliance. Check for gas leaks using a soap and water solution or leak detection solution. Bubbles indicate a leak that MUST be corrected. Do not use an open flame to test for gas leaks.
18. Check the air shutter opening. See chart and illustration below.
19. Relight the main burners and verify proper burner ignition and operation.
20. With the main burner burning, read the pressure on the manometer or pressure gauge. The pressure on the gauge should read between 9.8" and 10.2"w.c.
21. Turn off the gas supply. Turn off the electrical supply to the appliance.
22. Remove the manometer or pressure gage. Tighten the screw in the pressure tap.
23. Turn on the gas supply. Turn on the electrical supply to the appliance.
24. Immediately test all gas line connections and the control valve for gas leaks using a soap and water solution or gas detection for solution. Bubbles indicate a leak that MUST be corrected. Do not use an open flame to check for gas leaks.
25. Using a ball point pen, fill out the conversion label that is supplied with the conversion kit. Place the conversion label adjacent to the rating plate.
26. Test operation of fireplace once again. Allow the fireplace to operate for at least 10 minutes and check flame coloration. Flame on rear of burner should be yellow without any orange-colored tip. Minor adjustment of the air shutter may be necessary to "tune in" the proper flame color.

The burner flame and pilot flame must be checked for proper flame characteristics, as outlined in this manual.

VERIFYING INPUT RATE OF CONVERTED FIREPLACE

The input of the fireplace must be checked as follows:

1. Turn off all other gas appliances. Clock the gas meter and determine the number of seconds required to consume one cubic foot of gas.
2. $3600 \div \text{time (in seconds)} = \text{cu. ft. per hour}$.
3. Then $\text{cu. ft. per hour} \times \text{heating value of gas} = \text{input rate (BTU/Hr)}$. On installation without gas meters, check manifold for proper pressure.

Note: The rate noted on the data plate is measured after 45 minutes of continuous operation and adjusted for test conditions such as temperature, and barometric pressure. The above procedure is a check for correct conversion only.

PLACEMENT OF GAS CONVERSION LABEL

Conversion label 2139 is to be filled out completely and placed with the data plate attached near the valve.

If the appliance has not been installed, or a warranty card has not been returned to Empire Comfort Systems, Inc., check off type of gas converted to on card (for reference once the unit is installed). Also, indicate conversion by adding "Conv." behind gas.

MODEL	AIR SHUTTER SETTINGS	BURNER ORIFICE
	Opening "A"	Propane/LP
BVD34	5/16" (7.9mm)	1.35mm P-289
BVD36	5/16" (7.9mm)	1.45mm P-208
BVP42	FULL OPEN	1.65mm P-250

Air shutter settings shown are factory settings. Some venting configurations may require minor air shutter adjustments for optimum performance.

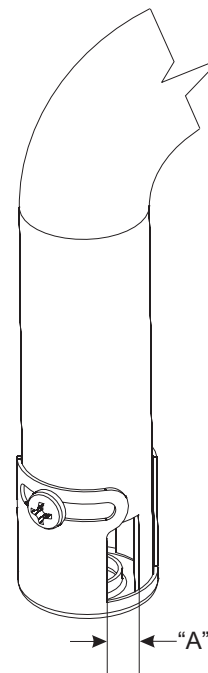

DIRECT IGNITION WIRING DIAGRAM

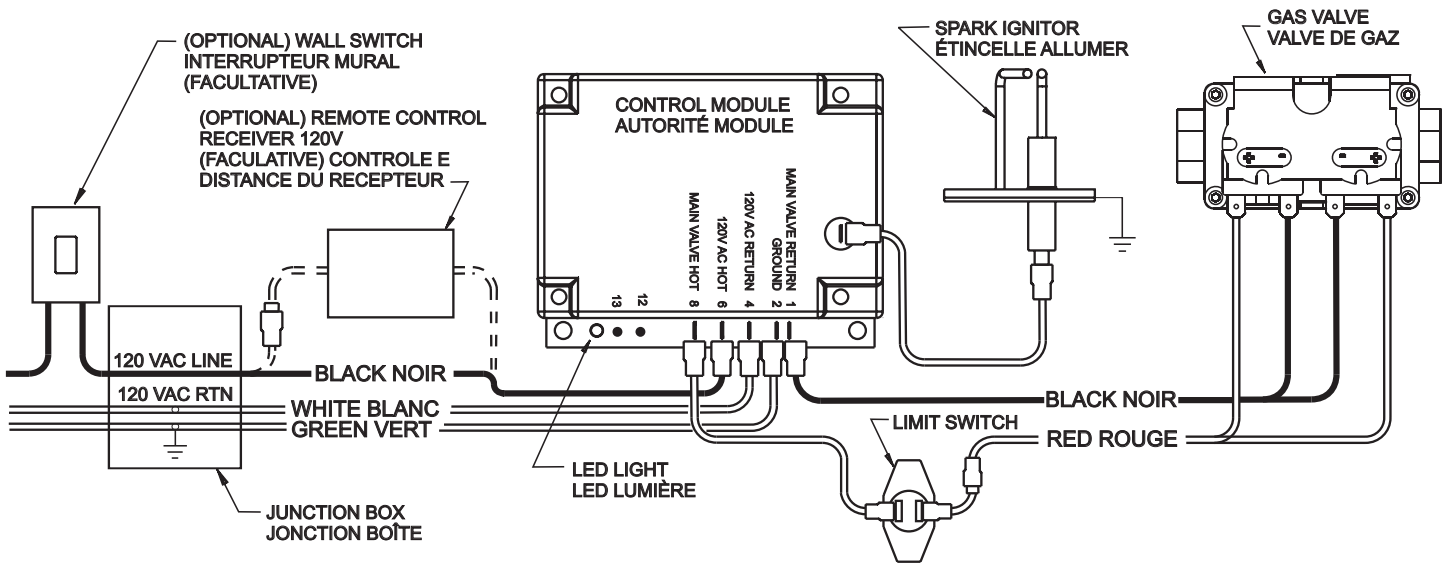

Figure 24

LED CODES	
Steady ON	Normal operation, power ON to control
2 Flashes	3 unsuccessful ignition trials
3 Flashes	Main burner flame failed 4 times during a single heating cycle
4 Flashes	Interrupt power for 5 seconds to reset control
Steady Flash	Flame detected out of sequence

OPTIONAL REMOTE CONTROL (120V DIRECT IGNITION)

Electric (120 volt) Operated Remote Control (FREC)

1. Disconnect 3-prong power cord from receptacle.
2. Remove wire from 120 VAC hot terminal on control module.
3. Connect female terminal from receiver onto 120 VAC hot terminal on control module.
4. Connect remaining wire from remote control (male terminal) to (female terminal) on power cord removed from control module (step 2).
5. Insert electric remote control power cord plug into the junction box on the right side of fireplace.
6. Connect 3-prong plug into receptacle. See wiring diagram on page 34.

DIRECT IGNITION LIGHTING INSTRUCTIONS

FOR YOUR SAFETY READ BEFORE LIGHTING

WARNING: IF YOU DO NOT FOLLOW THESE INSTRUCTIONS EXACTLY, A FIRE OR EXPLOSION MAY RESULT CAUSING PROPERTY DAMAGE, PERSONAL INJURY, OR LOSS OF LIFE.

- A. BEFORE LIGHTING smell all around the appliance area for gas. Be sure to smell next to the floor because some gas is heavier than air and will settle on the floor.

WHAT TO DO IF YOU SMELL GAS

- Do not try to light any appliance
- Do not touch any electrical switch
- Do not use any phone in your building.
- Immediately call your gas supplier from a neighbor's phone.
- Follow the gas supplier's instructions.
- If you can not reach your gas supplier, call the fire department.

- B. Use only the wall switch or remote control switch to turn the gas control on/off. Any attempted repairs or adjustments should be performed by a qualified service technician. Applying force or attempted repair may result in a fire or explosion.
- C. Do not use this appliance if any part has been under water. Immediately call a qualified service technician to inspect the appliance and to replace any part of the control system and any gas control which has been under water.

LIGHTING INSTRUCTIONS

1. STOP! Read the safety information above.
2. Turn off all electric power to the appliance.
3. This appliance is equipped with an ignition device that automatically lights the burner. Do not try to light the burner by hand.
4. Open bottom louver assembly, or open valve access door.
5. Turn gas line valve to "ON."
6. Wait five (5) minutes to clear out any gas. Then smell for gas, including near the floor. If you smell gas, STOP! Follow "A" in the safety information on reverse. If you do not smell gas, go to the next step.

7. Close bottom louver assembly, or close hearth access plate.
8. Turn on all electric power to the appliance.
9. If the appliance will not operate, follow the instructions "TO TURN OFF GAS TO APPLIANCE," and call your service technician or gas supplier.

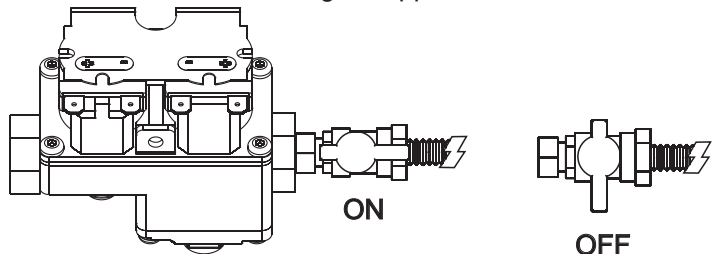

TO TURN OFF GAS TO APPLIANCE

1. STOP! Read the safety information above.
2. Turn off all electric power to the appliance.
3. Open bottom louver assembly, or open the valve access door.
4. Turn gas line valve to "OFF."
5. Close bottom louver assembly, or close valve access door.

INITIAL START UP GAS LINE PURGE

NOTE: UNIT MUST BE PROPERLY GROUNDED FOR ELECTRONIC IGNITION TO FUNCTION.

On initial installation, or after extended periods where the fireplace has not been used, gas lines may require purging.

DIRECT IGNITION TROUBLESHOOTING

With proper installation and maintenance, your new Gas Fireplace will provide years of trouble-free service. If you do experience a problem, refer to the troubleshooting guide below. This guide will assist a qualified service person in the diagnosis of problems and the corrective action to be taken. Refer to page 24 for initial startup and GAS Line purge instructions.

SYMPTOM	CHECK	ACTION
No spark when system is turned to "ON" and reset cycle* has been completed.	Check for 120V between black "hot" line at control module and "white" return at module.	If 120V not present, check fuse or circuit breaker or repair wiring leading to fireplace.
Spark for six (6) seconds at ignitor, but no ignition of burner.	a. Check that gas is turned on and system purged.	Turn gas on and/or purge system.
	b. Check that tips of ignitor are directly above ports on main burner. Spark is between electrodes and not from one electrode to burner.	Position electrodes so tips are directly above burner port ports and about 1/4" to 3/8" above burner.
	c. Check for 120V at each coil on the gas valve and listen for click, indicating gas valve is opening.	If 120V present, but gas valve does not click, replace gas valve.
Spark for six (6) seconds, main burner lights, but goes out when spark stops.	Check for clean ground path between electrode bracket and fireplace chassis. Check wiring to wiring diagram label. Check for broken electrode on high-tension lead attachment to module.	Clean, position according to wiring diagram, and repair defective electric connections. If all electrical connections are clean and correct, replace module.
Main burner lights normally and then goes out.	a. Check ignitor to burner gap.	Igniter should be located 1/4" to 3/8" above burner area.
	b. Check high-tension lead and connector for shorts.	Replace spark electrode assembly.
	c. Refer to installation instructions troubleshooting guide for issues such as venting.	Repair as required.

DIRECT IGNITION PROPANE/LP GAS CONVERSION

The conversion shall be carried out in accordance with the requirements of the provincial authorities having jurisdiction and in accordance with the requirements of the CSA B149.2 installation code (Canada) and with the requirements of the National Fuel Gas Code Z223.1/NFPA 54 (United States).

WARNING: This conversion kit shall be installed by a qualified service agency in accordance with the manufacturer's instructions and all applicable codes and requirements of the authority having jurisdiction. If the information in this instruction is not followed exactly, a fire, explosion, or production of carbon monoxide may result causing property damage, personal injury, or loss of life. The qualified service agency is responsible for the proper installation of this kit. The installation is not proper and complete until the operation of the converted appliance is checked as specified in the manufacturer's instructions supplied with the kit.

Installer notice: Using an ink pen, fill out the required information on the conversion label. Remove the backing from label and stick label in a visible position on bottom of fireplace close to gas valve.

Installer notice: These instructions must be left with the appliance.

Instructions for converting your direct ignition fireplace from natural gas to propane/LP gas.

All direct ignition fireplaces are shipped from the factory equipped to operate on natural gas. To convert the direct ignition fireplace to operate on propane/LP gas, follow the instructions on Page 26. Please see the appropriate parts list for your model for parts included with the direct ignition fireplace.

Check the items in the kit with the parts list. Notify the supplier of any items that are missing before installing the conversion kit.

DIRECT IGNITION PROPANE/LP GAS CONVERSION

1. Turn off the gas supply.
2. Turn off the electrical supply to the appliance if so equipped.
3. Open or remove glass doors if applicable.
4. Remove top louver and lower bottom louver.
5. Remove logs from burner assembly.

VALVE CONVERSION

6. Remove plastic cap from regulator fitting. Unscrew fitting using a 7/16" wrench. Turn fitting over so end of fitting marked "LPG" is visible. Tighten fitting (snug only). Replace plastic cap.
7. Remove 1/4" screw from air shutter.
8. Located to the right of electrodes is a burner hold-down tab. Using needle-nose pliers, bend burner hold-down tab off the main burner.
9. Remove main burner by pivoting main burner forward as you slide main burner from left to right. Be careful as you remove main burner in order to protect the electrodes from being damaged.
10. Remove air shutter from orifice fitting.
11. Remove natural gas main burner orifice from orifice fitting.
12. Install propane/LP main burner orifice marked 1.35mm for BVD34FP50, marked 1.45 mm for BVD36FP52, or marked 1.65mm for BVP42FP52.

Important: Failure to install the correct orifice will result in unit over-firing that could overheat the appliance and result in a fire.
13. Replace air shutter onto orifice fitting. Air shutter must be threaded and bottomed-out onto orifice fitting.
14. Replace main burner onto burner assembly. Place main burner beneath electrodes, slide main burner from right to left into burner location, and pivot main burner away from you and into air shutter.
15. Set air shutter opening as indicated by the chart below. Tighten air shutter in place with 1/4" screw from step 7.
16. Using needle-nose pliers, bend burner hold-down tab over main burner.
17. Refer to log placement, pages 14 and 15 to place logs onto burner assembly.
18. Loosen screw and attach a manometer or pressure gauge to the outlet pressure tap of the control valve.
19. Turn on the gas supply. Turn on the electrical supply to the appliance. Check for gas leaks using soap and water solution or leak detection solution. Bubbles indicate a leak that MUST be corrected. Do not use an open flame to test for gas leaks.

20. Check the air shutter opening. See chart and illustration below.
21. Relight the main burners and verify proper burner ignition and operation.
22. With the main burner burning, read the pressure on the manometer or pressure gauge. The pressure on the gauge should read between 9.8" and 10.2" w.c.
23. Turn off the gas supply. Turn off the electrical supply to the appliance.
24. Remove the manometer or pressure gauge. Tighten the screw in the pressure tap.
25. Turn on the gas supply. Turn on the electrical supply to the appliance.
26. Immediately test all gas line connections and the control valve for gas leaks using a soap and water solution or other gas detection solution. Bubbles indicate a leak that MUST be corrected. Do not use an open flame to test for gas leaks.
27. Using a ball point pen, fill out the conversion label that is supplied with the conversion kit. Place the conversion label adjacent to the rating plate.
28. Test operation of fireplace once again. Allow the fireplace to operate for at least 10 minutes and check flame coloration. Flames on rear of burner should be yellow without any orange-colored tip. Minor adjustment of the air shutter may be necessary to "tune in" the proper flame color.

Model	AIR SHUTTER SETTINGS	BURNER ORIFICE
	Opening "A"	Propane/LP Orifice
BVD34	5/16" (8mm)	1.35mm
BVD36	5/16" (8mm)	1.45mm
BVP42	Full Open	1.65mm

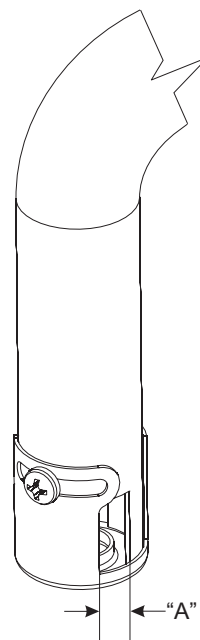

Maxitrol Valve Conversion

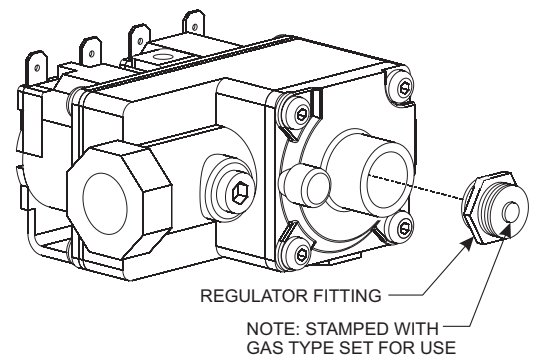

MAINTENANCE AND SERVICE

PLEASE NOTE

It is normal for appliances fabricated of steel to give off some expansion and/or contraction noise during the start up or cool down cycle. Similar noises are found with your furnace heat exchanger or car engine.

It is not unusual for your gas fireplace to give off some odor the first time it is burned. This is due to the curing of the paint and any undetected oil from the manufacturing process.

Please ensure that your room is well ventilated - open all windows.

It is recommended that you burn your fireplace for at least six (6) hours the first time you use it. If optional fan kit has been installed, place fan in the "OFF" position during this time.

IMPORTANT: Turn off gas before servicing appliance. It is recommended that a qualified service person perform these check-ups at the beginning of each heating season.

• Clean Burner and Control Compartment

Keep the control compartment, logs, and burner areas surrounding the logs clean by vacuuming or brushing at least twice a year.

Cleaning Procedure

1. Turn off pilot light at gas valve.
2. Vacuum burner compartment.
3. Ignite pilot (if applicable). (See Lighting Instructions)
4. Operate the pilot burner (if applicable). If it appears abnormal call a service person.

• Check Vent System

The appliance and venting system should be inspected before initial use and at least annually by a qualified service person. Inspect the external vent cap on a regular basis to make sure that no debris is interfering with the air flow.

Glass Cleaning (Optional Kits)

It will be necessary to clean the glass periodically. During start-up condensation, which is normal, forms on the inside of the glass and causes lint, dust and other airborne particles to cling to the glass surface. Also initial paint curing may deposit a slight film on the glass. It is therefore recommended that the glass be cleaned two or three times with a non-abrasive household cleaner and warm water (we recommend gas fireplace glass cleaner). After that the glass should be cleaned two or three times during each heating season depending on the circumstances present.

General Glass Information

Only glass approved for use by the manufacturer may be used for replacement. The glass replacement should be done by a licensed or qualified service person.

WARNING:

1. The use of substitute glass will void all product warranties.
2. Care must be taken to avoid breakage of glass.
3. Do not abuse the glass by striking or hitting the glass.

WARNING: Do not use abrasive cleaners on glass. Do not attempt to clean glass when glass is hot.

BVD34 & BVD36 PARTS LIST

INDEX NO.	PART NUMBER				DESCRIPTION
	BVD34L	BVD34F	BVD36L	BVD36F	
1	19506	19506	19507	19507	TOP SHIELD
2	17301	17301	17301	17301	TOP STANDOFF (2 REQUIRED)
3	10554	10554	10554	10554	NAILING FLANGE (4 REQUIRED)
4	M163	M163	M178	M178	FLUE OUTLET GASKET
5	19387	19387	19422	19422	FLUE OUTLET ASSEMBLY
6	19398	19398	19398	19398	DOWNDRAFT BAFFLE
7	19402	19402	19434	19434	DRAFT BAFFLE
8	R7052	R7052	R7052	R7052	SCREEN ROD
9	R8137	R8137	R8148	R8148	SCREEN
10	17127	N/A	18807	N/A	UPPER LOUVER ASSEMBLY
11	17128	N/A	18808	N/A	LOWER LOUVER ASSEMBLY
12	17162	17162	17162	17162	JUNCTION BOX ASSEMBLY (DIRECT IGNITION & LOUVERED MODELS ONLY)
12a	17163	17163	17163	17163	JUNCTION BOX COVER PLATE
13	R3492	R3492	R3492	R3492	RECEPTACLE (DIRECT IGNITION & LOUVERED MODELS ONLY)
14	19435	19435	19436	19436	VALVE ACCESS DOOR
15	17235	17235	17235	17235	LOG LOCATOR BRACKET
16	R7580	R7580	R8020	R8020	BURNER TUBE
17	R5676	R5676	R5676	R5676	AIR SHUTTER
18	P252	P252	P286	P286	ORIFICE (NAT)
19	R7572	R7572	R7572	R7572	JAMB NUT
20	P212	P212	P212	P212	ORIFICE HOLDER
21a	19384	19384	19420	19420	TUBING ASSEMBLY
21b	20208	20208	20209	20209	TUBING ASSEMBLY
22	R2423	R2423	R2423	R2423	MALE ADAPTOR
23	R7590	R7590	R7590	R7590	SPARK IGNITOR (DIRECT IGNITION)
24	17315	17315	17315	17315	SPARK IGNITOR MOUNTING PLATE (DIRECT IGNITION)
25	R8132	R8132	R8132	R8132	PILOT (MILLIVOLT)
25a	R5710	R5710	R5710	R5710	THERMOPILE
26	R7617	R7617	R7617	R7617	PILOT GASKET
27	19382	19382	19418	19418	BURNER BASE ASSEMBLY
28a	19381	19381	19381	19381	VALVE BRACKET (MILLIVOLT)
28b	19403	19403	19403	19403	VALVE BRACKET (DIRECT IGNITION)
29a	R8380	R8380	R8380	R8380	VALVE, GAS (MILLIVOLT)
29b	R7568	R7568	R7568	R7568	VALVE, DIRECT IGNITION (120V)
30	R2708	R2708	R2708	R2708	PIEZO IGNITOR (MILLIVOLT)
31	R7613	R7613	R7613	R7613	IGNITOR WIRE (SPARK PLUG WIRE) (DIRECT IGNITION)
32	R8143	R8143	R8143	R8143	CONTROL MODULE, ELECTRONIC (DIRECT IGNITION)
33	R8144	R8144	R8144	R8144	WIRE ASSEMBLY (DIRECT IGNITION)
34	R7615	R7615	R7615	R7615	CORD SET (DIRECT IGNITION)
35a	R8133	R8133	R8133	R8133	WIRE ASSEMBLY, LIMIT SWITCH (MILLIVOLT)
35b	R8147	R8147	R8147	R8147	WIRE ASSEMBLY, LIMIT SWITCH (DIRECT IGNITION)
36	R8145	R8145	R8145	R8145	WIRE ASSEMBLY, WALL SWITCH (ON/OFF)
37	R7587	R7587	R7556	R7556	REAR LOG
38	R7586	R7586	R7555	R7555	MIDDLE LOG
39	R7585	R7585	R7553	R7553	FRONT LEFT LOG
40	R-7588	R7588	R7557	R7557	Y BRANCH
41	R7554	R7554	R7554	R7554	FRONT RIGHT LOG
42	R7591	R7591	R7591	R7591	FLEX LINE/SHUTOFF VALVE
43	R8593	R8593	R8375	R8375	SWITCH, LIMIT

USE ONLY MANUFACTURER'S REPLACEMENT PARTS. USE OF ANY OTHER PARTS COULD CAUSE INJURY OR DEATH.

BVD34 & BVD36 PARTS VIEW

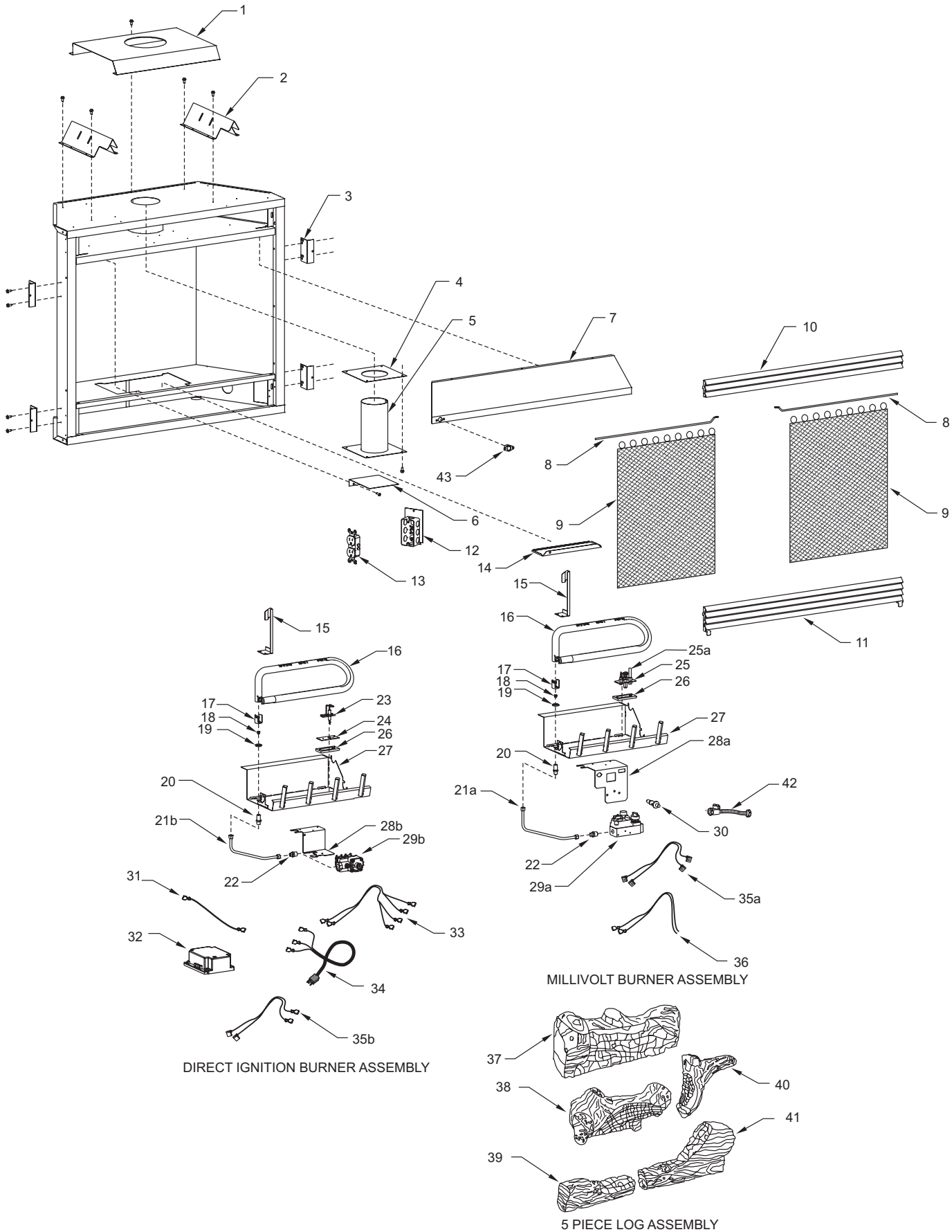

BVP42 PARTS LIST

INDEX NO.	PART NUMBER	PART NUMBER		DESCRIPTION
	BVP42L	BVP42F		
1	19508	19508		TOP SHIELD
2	17247	17247		TOP STANDOFF (2 REQUIRED)
3	10554	10554		NAILING FLANGE (4 REQUIRED)
4	M178	M178		FLUE OUTLET GASKET
5	19422	19422		FLUE OUTLET ASSEMBLY
6	19398	19398		DOWNDRAFT BAFFLE
7	19467	19467		DRAFT BAFFLE
8	R7053	R7053		SCREEN ROD
9	R8148	R8148		SCREEN
10	17187	N/A		UPPER LOUVER ASSEMBLY
11	17188	N/A		LOWER LOUVER ASSEMBLY
12	17162	17162		JUNCTION BOX ASSEMBLY (DIRECT IGNITION AND LOUVERED MODELS ONLY)
12a	17163	17163		JUNCTION BOX COVER PLATE
13	R3492	R3492		RECEPTACLE (DIRECT IGNITION & LOUVERED MODELS ONLY)
14	19437	19437		VALVE ACCESS DOOR
15	P200	P200		ORIFICE HOLDER
16	P213	P213		ORIFICE
17	R5676	R5676		AIR SHUTTER
18	11499	11499		BURNER SUPPORT LEFT SIDE
19	17370	17370		BURNER ASSEMBLY
20a	20210	20210		TUBING ASSEMBLY
20b	19470	19470		TUBING ASSEMBLY
21	R2423	R2423		MALE ADAPTER
22	11377	11377		BURNER SUPPORT RIGHT
23	R7590	R7590		SPARK IGNITOR (DIRECT IGNITION)
24	R7612	R7612		PILOT (MILLIVOLT)
24a	R5710	R5710		THERMOPILE
25	19545	19545		SPARK IGNITOR SHIELD (DIRECT IGNITION)
26	R7617	R7617		PILOT GASKET (MILLIVOLT)
26a	M173	M173		PILOT GASKET (DIRECT IGNITION)
27	19455	19455		BURNER BASE ASSEMBLY
28a	19381	19381		VALVE BRACKET (MILLIVOLT)
28b	20207	20207		VALVE BRACKET (DIRECT IGNITION)
29a	R8380	R8380		VALVE, MILLIVOLT GAS
29b	R7733	R7733		VALVE, DIRECT IGNITION GAS (120V)
30	R2708	R2708		PIEZO IGNITOR (MILLIVOLT)
31	R7613	R7613		IGNITOR WIRE (SPARK PLUG WIRE) (DIRECT IGNITION)
32	R8143	R8143		CONTROL MODULE, ELECTRONIC (DIRECT IGNITION)
33	R8144	R8144		WIRE ASSEMBLY (DIRECT IGNITION)
34	R7615	R7615		CORD SET (DIRECT IGNITION)
35a	R8133	R8133		WIRE ASSEMBLY, LIMIT SWITCH (MILLIVOLT)
35b	R8147	R8147		WIRE ASSEMBLY, LIMIT SWITCH (DIRECT IGNITION)
36	R8145	R8145		WIRE ASSEMBLY, THERMOSTAT
37	R10352	R10352		LOG, TOP BRANCH
38	R10349	R10349		LOG, REAR
39	R10350	R10350		LOG, FRONT LEFT
40	R10351	R10351		LOG, FRONT RIGHT
41	R8594	R8594		SWITCH, LIMIT
42	R7591	R7591		FLEX LINE/SHUTOFF VALVE

BVP42 PARTS VIEW

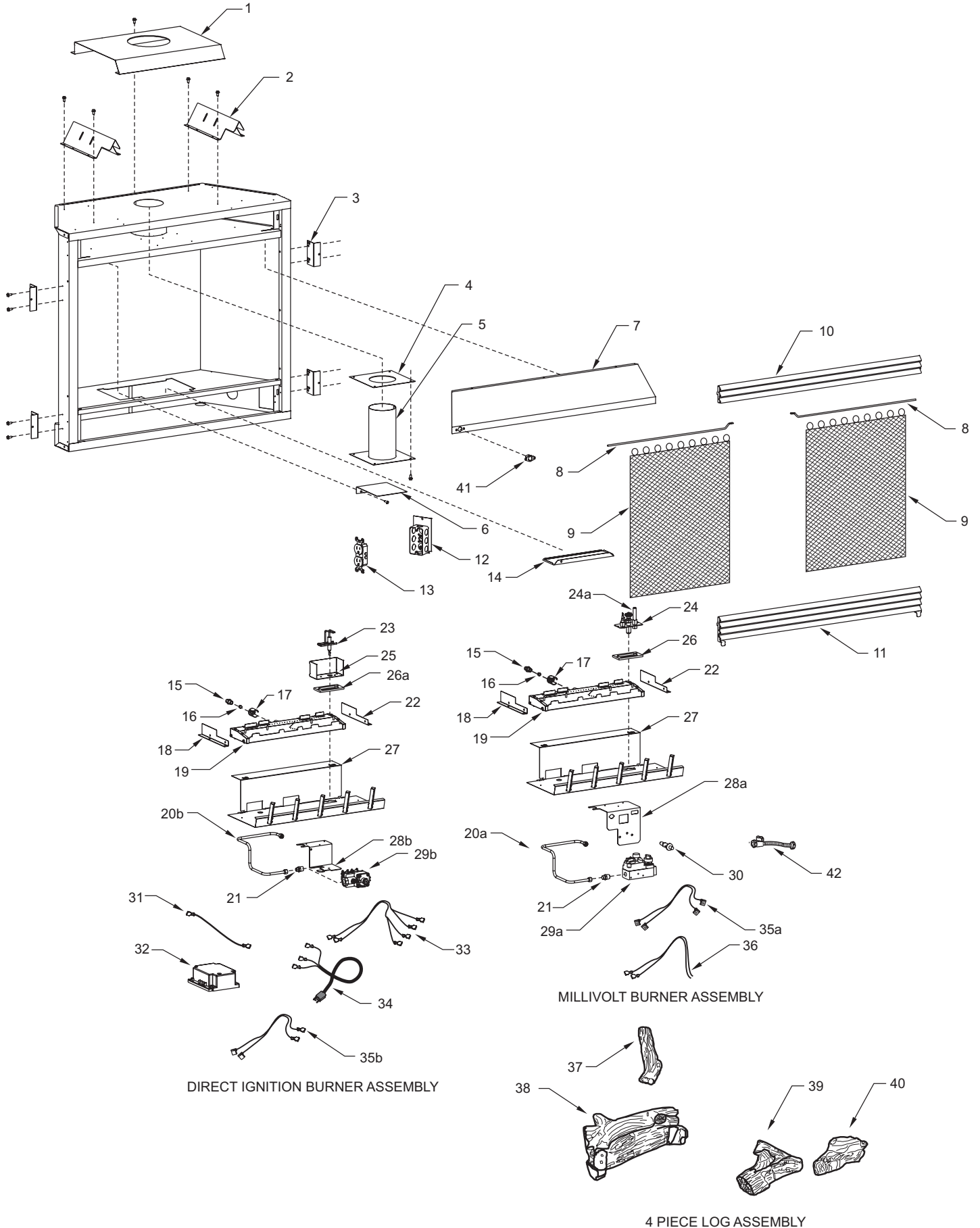

FBB4 OPTIONAL VARIABLE SPEED BLOWER INSTALLATION

Attention: Install blower assembly before connecting gas inlet supply line

Note: Junction box on right side of fireplace must be pre-wired at time of fireplace installation for use with blower assembly. It is recommended that an ON/OFF wall switch be installed that will activate the power supply to the furnace by a qualified electrician.

1. If installed, turn OFF gas supply to fireplace.
2. If applicable, turn OFF electric supply to fireplace.
3. Lower bottom louver on fireplace.
4. Refer to page 34, "Junction Box Wiring Installation Instructions" to complete wiring of junction box.

Attention: If installed, do not damage gas inlet supply line when blower assembly is inserted into fireplace. If necessary, remove gas inlet supply line.

5. Insert blower assembly into interior, bottom of fireplace. Position blower assembly behind gas valve, align notch on back of blower assembly with center screw on fireplace back and push blower assembly against fireplace back. The magnets on the back and bottom of blower assembly will sufficiently hold blower assembly in place.
6. Position speed control box to the right of gas valve. Attach speed control box to bottom of fireplace. The magnets on bottom of speed control box will sufficiently hold speed control box in place.
7. With base (flush face) of fan control switch facing upward, insert base of fan control switch under the mounting tabs on valve bracket. The base (flush face) of fan control switch must be in contact with bottom of firebox.
8. Insert power cord plug into junction box.
9. Close bottom louver on fireplace.
10. Installation of FBB4 optional variable speed blower assembly is completed.

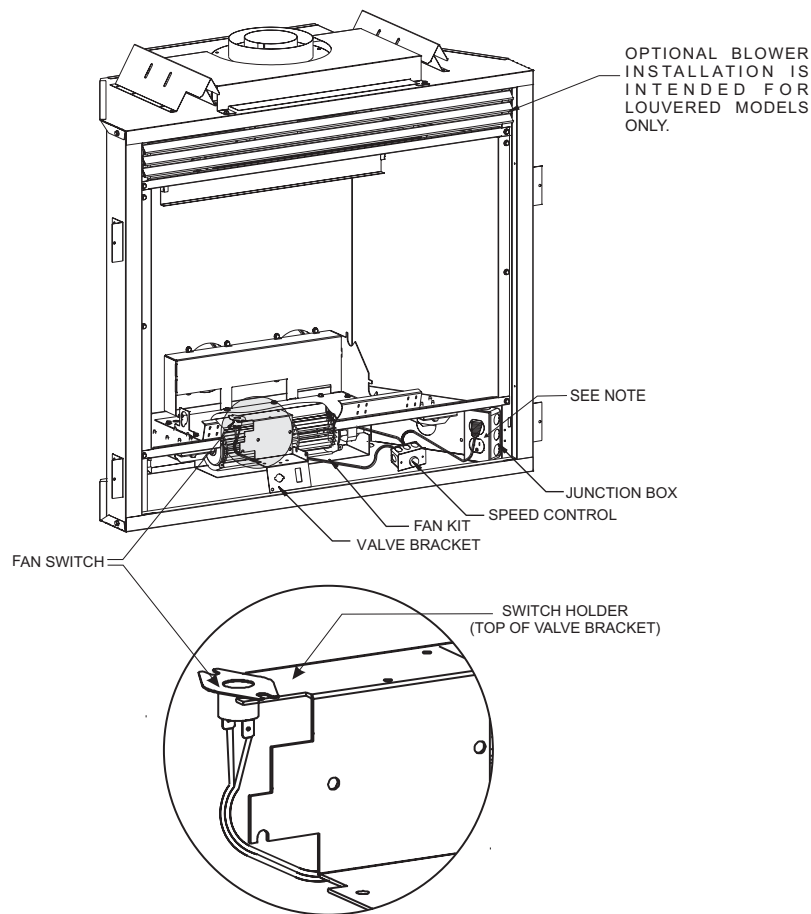

Note: Refer to wiring instructions on page 33 for proper operation.

Figure 25

FBB4 OPTIONAL VARIABLE SPEED BLOWER INSTALLATION

1	FBB4	BLOWER ASSEMBLY COMPLETE
2	R7649	FAN CONTROL
3	R4192	SPEED CONTROL KNOB
4	R4186	SPEED CONTROL

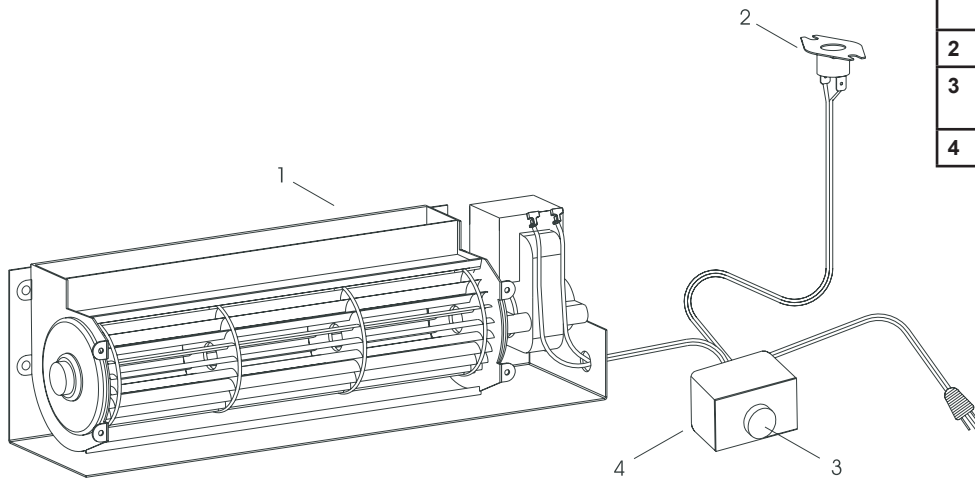

Figure 26

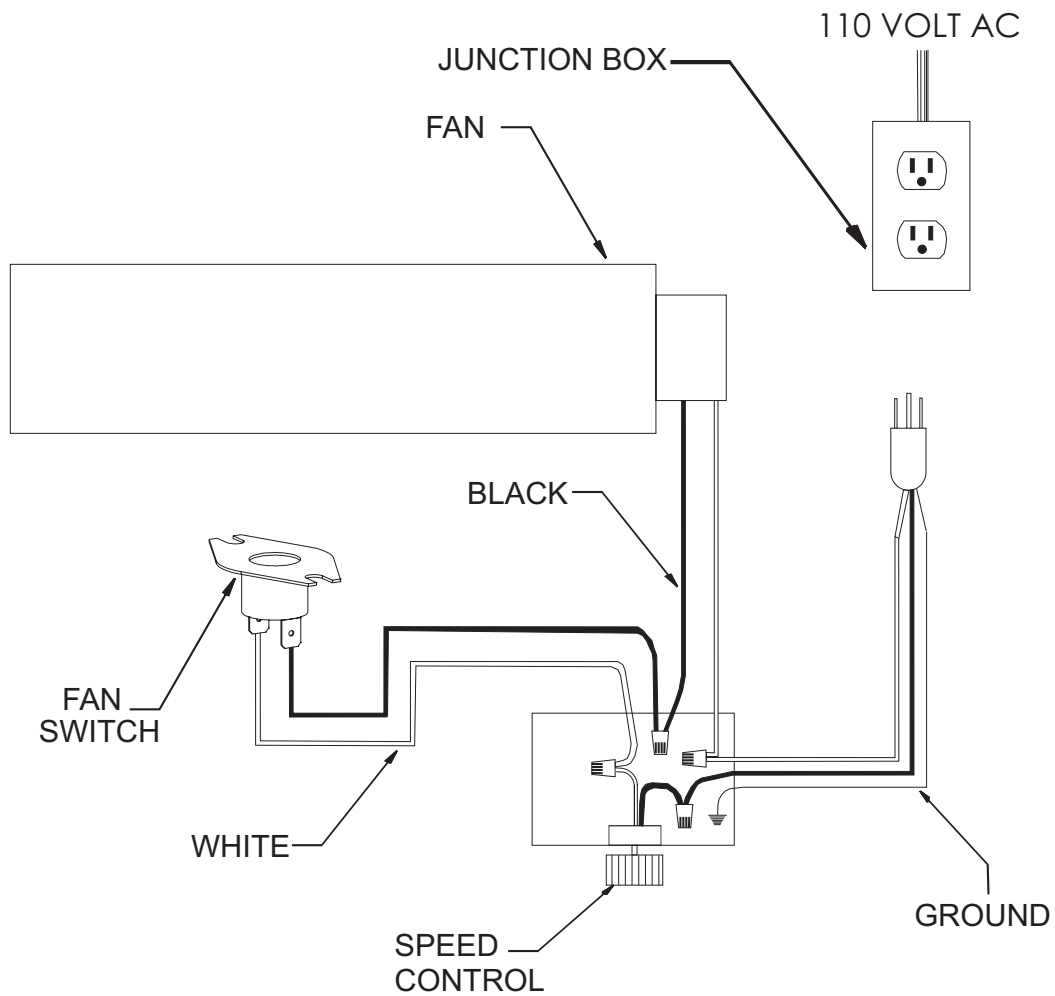

Figure 27

JUNCTION BOX WIRING INSTALLATION INSTRUCTIONS

STANDARD MILLIVOLT VALVE MODELS

CAUTION: ALL WIRING SHOULD BE DONE BY A QUALIFIED ELECTRICIAN AND SHALL BE IN COMPLIANCE WITH ALL LOCAL, CITY AND STATE BUILDING CODES. BEFORE MAKING THE ELECTRICAL CONNECTION, MAKE SURE THAT MAIN POWER SUPPLY IS DISCONNECTED. THE APPLIANCE, WHEN INSTALLED, MUST BE ELECTRICALLY GROUNDED IN ACCORDANCE WITH LOCAL CODES OR, IN THE ABSENCE OF LOCAL CODES, WITH THE NATIONAL ELECTRICAL CODE ANSI/NFPA 70 (LATEST EDITION).

A factory installed junction box is located on the lower right side of the fireplace. Wiring must be fed to the junction box and attached to the receptacle that is provided. Leave approximately 6" of wire in the junction box for connection.

Attach black wire to one side of the receptacle and white wire to opposite side of receptacle. The ground wire should be attached to the green (ground) screw.

Install the receptacle into the junction box. Attach cover plate.

JUNCTION BOX CONNECTIONS

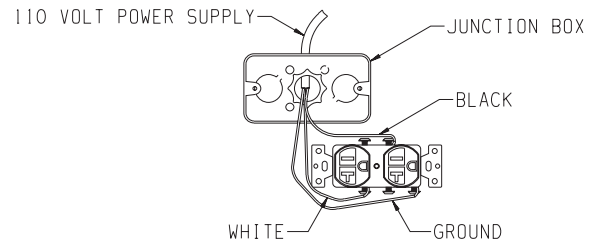
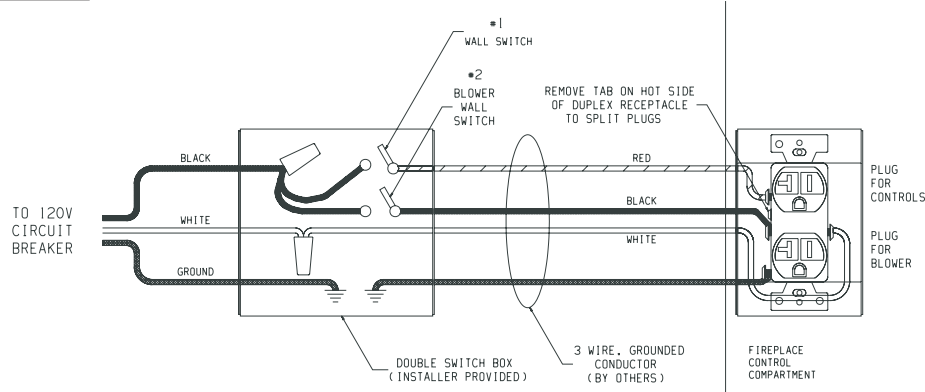

Figure 28

120V DIRECT IGNITION VALVE MODELS



DUAL SWITCH ELECTRICAL WIRING TO FIREPLACE RECEPTACLE

Figure 29

1. To wire Junction Box Receptacle, remove the tab on the side of the receptacle (hot side) to split receptacle. This will be required to separate blower and valve circuits.
2. Power for switched and live sides of Duplex Receptacle must come from the same power source. (One circuit breaker on main panel must switch all power off.)
3. From the wall box to the fireplace a 3-wire conductor with ground is recommended, however (2) two-wire conductors with grounds may be used in place of a 3-wire conductor with a ground if the black wires from the thermostat and blower switch are identified.
4. Two wall switches, or a wall switch and thermostat may be used to activate the two receptacle plugs independently.

BARRIER SCREENS

FIREPLACE BARRIER SCREENS

SCREEN MODEL	DESCRIPTION	FIREPLACE MODELS USED ON
BWB2BL	Door Barrier Frame Kit - Matte Black	BVD34FP
BWB36BL	Door Barrier Frame Kit - Matte Black	BVD36FP
BWB3BL	Door Barrier Frame Kit - Matte Black	BVP42FP

Note: A firescreen is required for operation of the appliance, but are sold separately. Follow the instructions that come with your firescreen for proper installation.

OPTIONAL ACCESSORIES

The following accessory parts can be obtained from your Empire Comfort Systems dealer. If you need additional information beyond what your dealer can furnish, contact Empire Comfort Systems Inc., Nine Eighteen Freeburg Ave., Belleville, Illinois 62220-2623.

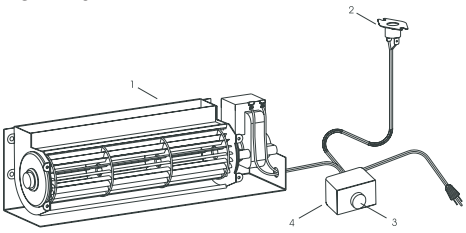
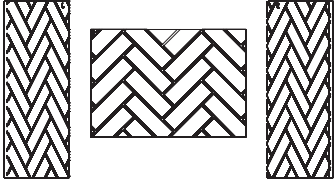
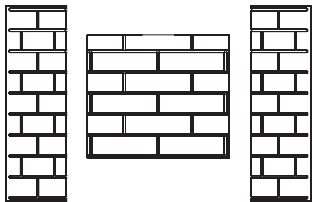
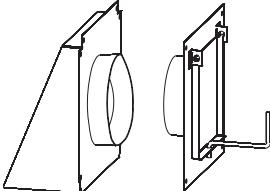
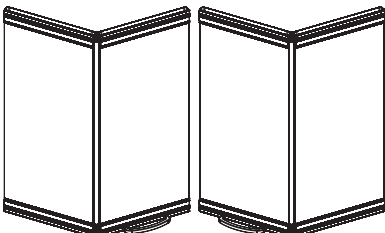
Accessory	Description	Model Number
<p>Fan Kit</p> 	<p>This fan kit was designed to provide forced air flow (for louvered models only).</p>	<p>Variable Speed FBB4</p>
<p>Simulated Brick Panels</p> 	<p>The simulated brick panels were designed to enhance the appearance of your fireplace, imitating the look of authentic masonry.</p> <p>HERRINGBONE</p>	<p>BVD2SH (BVD34FP) BVD36SH (BVD36FP) BVD3SH (BVP42FP)</p>
<p>Simulated Brick Panels</p> 	<p>The simulated brick panels were designed to enhance the appearance of your fireplace, imitating the look of authentic masonry.</p> <p>AGED BRICK</p>	<p>BVD2SA (BVD34FP) BVD36SA (BVD36FP) BVP3SA (BVP42FP)</p>
<p>Fresh Air Kit</p> 	<p>Installs to side of fireplace to provide fresh air make up when operating fireplace (optional).</p> <p>Note: Requires standard 4" diameter flexible or hard pipe connector (not included with kit)</p>	<p>BVA1</p>
	<p>Optional Bifold Glass Door Accessory.</p> <p>Includes bifold tempered glass doors and decorative canopy to give a finishing touch to your fireplace. Operational doors must remain open when operating the fireplace.</p>	<p>BVX2BL (BVD34FP) BVX36BL (BVD36FP) BVX3BL (BVP42FP)</p>

Please refer to the instructions included with the optional accessory kits for proper installation.
26534-5-0315

DECORATIVE ACCESSORIES



Decorative Louver Mission



Decorative Louver Arch



Decorative Louver Leaf



Decorative Frame Rectangle with hinges

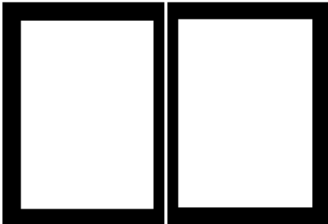

Decorative Door Plain Rectangle



Bottom Trim Frame

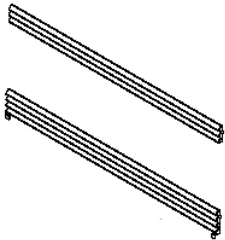

STD Louvers 45 Deg

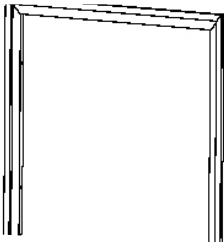

Outside Frame Kits

Please contact your nearest dealer/distributor for more information on all available optional decorative accessories.

MASTER PARTS DISTRIBUTOR LIST

To Order Parts Under Warranty, please contact your local Empire dealer. See the dealer locator at www.empirecomfort.com. To provide warranty service, your dealer will need your name and address, purchase date and serial number, and the nature of the problem with the unit.

To Order Parts After the Warranty Period, please contact your dealer or one of the Master Parts Distributors listed below. This list changes from time to time. For the current list, please click on the Master Parts button at www.empirecomfort.com. Please note: Master Parts Distributors are independent businesses that stock the most commonly ordered Original Equipment repair parts for Heaters, Grills, and Fireplaces manufactured by Empire Comfort Systems Inc.

Dey Distributing

1401 Willow Lake Boulevard
Vadnais Heights, MN 55101

Phone: 651-490-9191

Toll Free: 800-397-1339

Website: www.deyistributing.com

Parts: Heater, Hearth and Grills

Victor Division of F. W. Webb Company

200 Locust Street
Hartford, CT 06114

Phone: 860-722-2433

Toll Free: 800-243-9360

Fax: 860-293-0479

Toll Free Fax: 800-274-2004

Websites: www.fwwebb.com & www.victormfg.com

Parts: Heater, Hearth and Grills

East Coast Energy Products

10 East Route 36
West Long Branch, NJ 07764

Phone: 732-870-8809

Toll Free: 800-755-8809

Fax: 732-870-8811

Website: www.eastcoastenergy.com

Parts: Heater, Hearth and Grills

HOW TO ORDER REPAIR PARTS

Parts Not Under Warranty

Parts can be ordered through your Service Person, Dealer, or a Master Parts Distributor. See this page for the Master Parts Distributors list. For best results, the **service person or dealer** should order parts through the distributor. Parts can be shipped directly to the **service person/dealer**.

Warranty Parts

Warranty parts will need a proof of purchase and can be ordered by your Service Person or Dealer. Proof of purchase is **required** for warranty parts.

All parts listed in the Parts List have a Part Number. When ordering parts, first obtain the Model Number and Serial Number from the name plate on your equipment. Then determine the Part Number (**not** the Index Number) and the Description of each part from the following illustration and part list. Be sure to give all this information . . .

Appliance Model Number _____ Part Description _____

Appliance Serial Number _____ Part Number _____

Type of Gas (Propane or Natural) _____

Do not order bolts, screws, washers or nuts. They are standard hardware items and can be purchased at any local hardware store.

Shipments contingent upon strikes, fires and all causes beyond our control.

EMPIRE

COMFORT SYSTEMS

SINCE 1932

Empire Comfort Systems Inc. Web Site: www.empirecomfort.com
 918 Freeburg Ave.
 Belleville, IL 62220

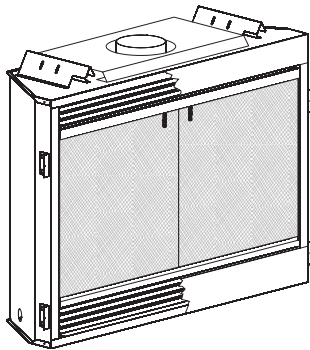

The Keystone "B" Vent Zero Clearance Gas Fireplace

MILLIVOLT: BVD34FP30(F,L)N-2; BVD36FP30(F,L)N-1; BVP42FP30(F,L)N-1
DIRECT IGNITION: BVD34FP50(F,L)N-1; BVD36FP50(F,L)N-1; BVP42FP50(F,L)N-1

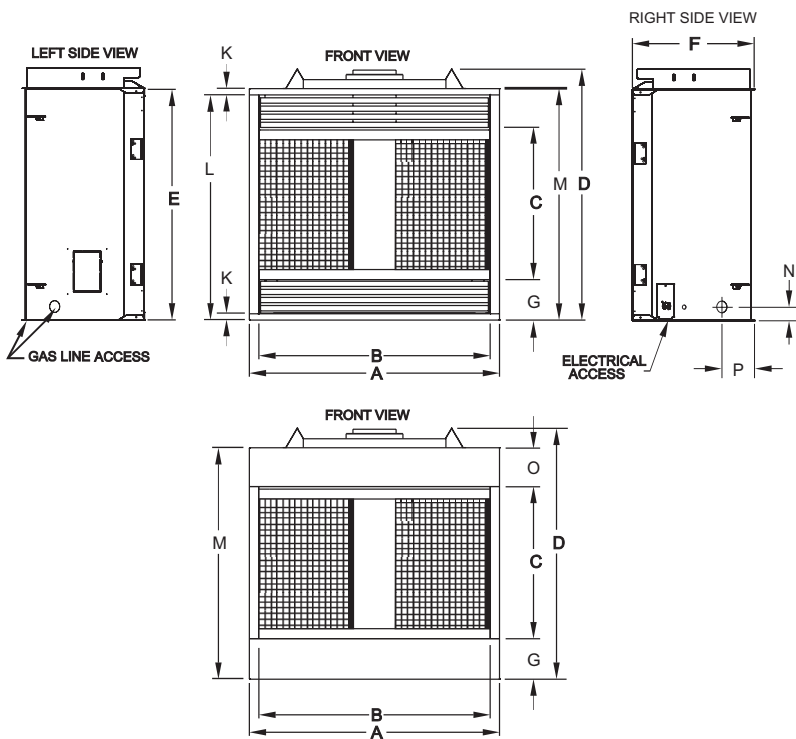

Dim	BVD34	BVD36	BVP42
A	37" 940mm	39" 990mm	43" 1092mm
B	34" 864 mm	36" 914mm	40" 1,016mm
C	22 7/8" 581mm	24 7/8" 632mm	24 7/8" 632mm
D	35 5/8" 905 mm	37 5/8" 956 mm	37 5/8" 956 mm
E	32 3/4" 832mm	34 3/4" 883 mm	34 3/4" 883 mm
F	14 7/8" 378mm	18 3/8" 467mm	18 3/8" 467mm
G	6 3/8" 162mm	6 3/8" 162mm	6 3/8" 162mm
H	5 7/8" 149mm	8 3/8" 213mm	6 3/8" 162mm
I	24 1/2" 622mm	22 1/2" 572mm	26 1/2" 673mm
J	12 1/4" 311mm	11 1/4" 286mm	13 1/4" 337mm
K	1 1/4" 32mm	1 1/4" 32mm	1 1/4" 32mm
L	31 3/4" 807mm	33 3/4" 857mm	33 3/4" 857mm
M	32 11/16" 830mm	34 11/16" 881mm	34 11/16" 881mm
N	2 1/16" 53mm	2 1/16" 53mm	2 1/16" 53mm
O	5 5/8" 143mm	5 5/8" 143mm	5 5/8" 143mm
P	4 7/8" 124mm	4 7/8" 124mm	4 7/8" 124mm

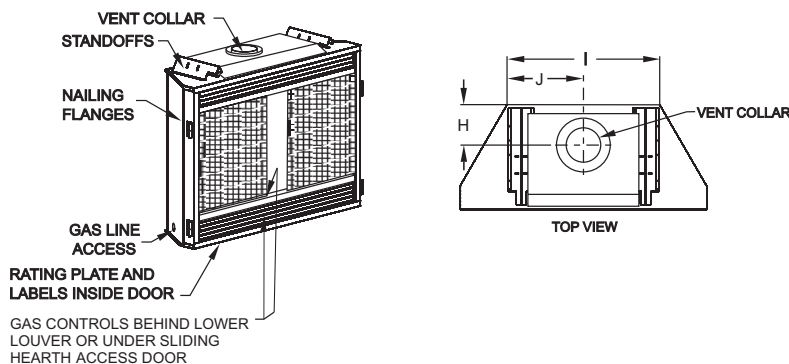

EMPIRE

COMFORT SYSTEMS

SINCE 1932

Empire Comfort Systems Inc. Web Site: www.empirecomfort.com
 918 Freeburg Ave.
 Belleville, IL 62220

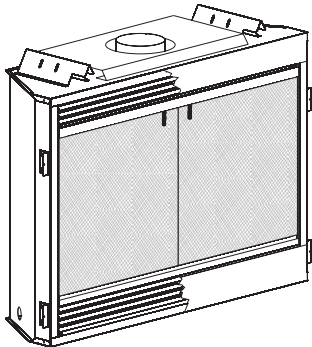

The Keystone "B" Vent Zero Clearance Gas Fireplace

MILLIVOLT: BVD34FP30(F,L)N-2; BVD36FP30(F,L)N-1; BVP42FP30(F,L)N-1
DIRECT IGNITION: BVD34FP50(F,L)N-1; BVD36FP50(F,L)N-1; BVP42FP50(F,L)N-1

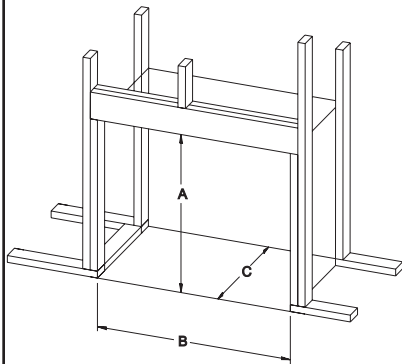

Minimum Framing Dimensions

	BVD34	BVD36	BVP42
"A"	35 3/4" (908mm)	37 3/4" (959mm)	37 3/4" (959mm)
"B"	37 3/8" (949mm)	39 3/8" (1,000mm)	43 3/8" (1,102mm)
"C"	14 3/8" (378mm)	17 7/8" (454mm)	17 7/8" (454mm)

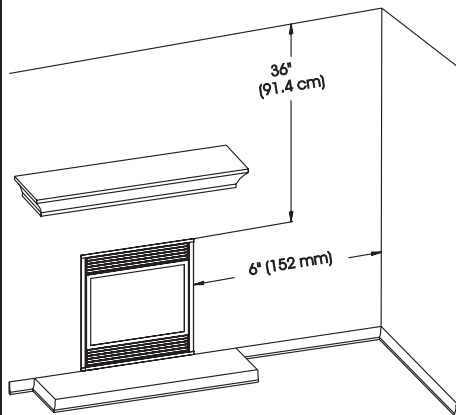
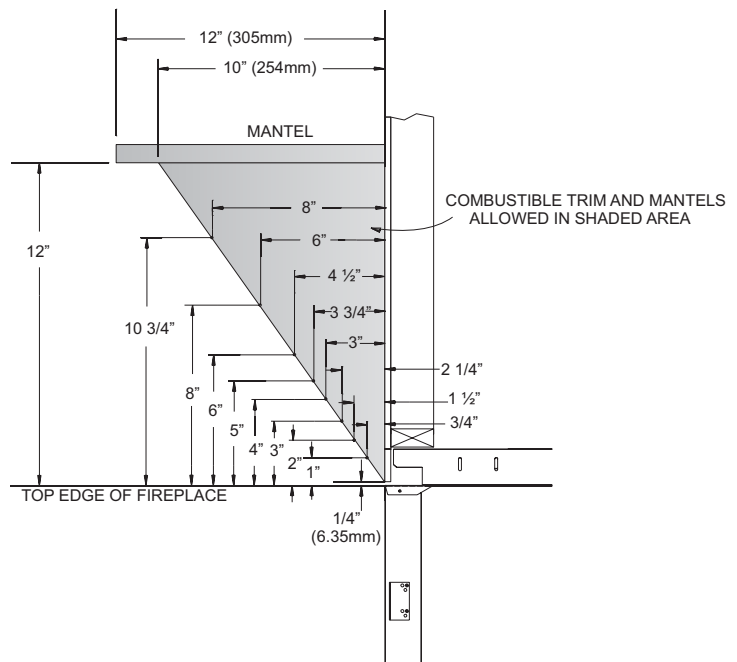

Clearance to Combustibles

Back	0" (0 mm)
Side	0" (0 mm)
Floor	0" (0 mm)
Top Stand-off	0" (0 mm)
Top Framing Edge	1" (25mm)

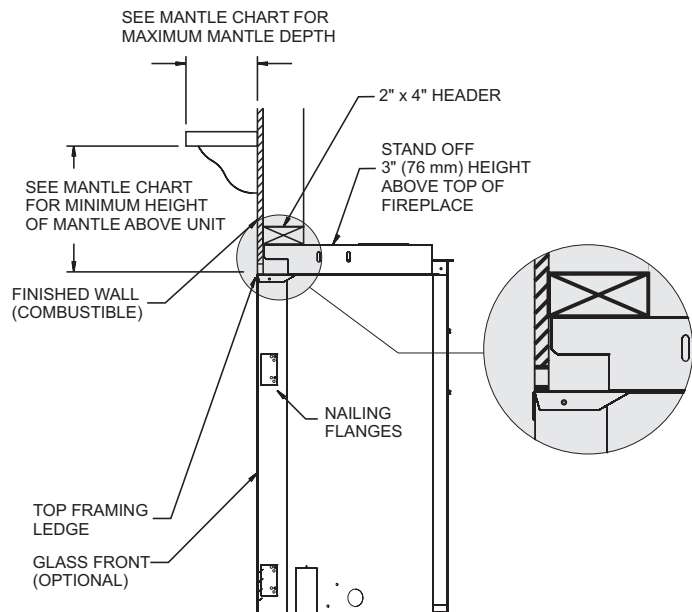



Empire Comfort Systems Inc.
918 Freeburg Ave. Belleville, IL 62220

If you have a general question about our products, please e-mail us at
info@empirecomfort.com.

If you have a service or repair question, please contact your dealer.

www.empirecomfort.com